



Orange Peel Rotating Shaft Guards

(Inch/Metric)



Table Of Contents

DESCRIPTION	PAGE
Orange Peel® Guards	4
Available in Polyethylene and Metal Types	5
Guard Types and Accessories	6
Guard Options	7
Safety Labels	8
Spare Hardware	8
Model-Series Description	9
Guard Assemblies	9
POLYETHYLENE GUARDS	
Type MCG Polyethylene Guards	10, 11
Type CCG Polyethylene Guards	12, 13
Type PCG Polyethylene Guards	14, 15
METAL TYPE GUARDS	
Type CFCG Metal Guards	16, 17
Type SCG Aluminum Guards	18, 19
Type LSG Aluminum Guards	20, 21
Type VCG Metal Guards	22
GUARD QUICK SELECTIONS	
Type MCG Polyethylene Guards - NEMA Motor Quick Selections	23
Type MCG Polyethylene Guards - IEC Motor Quick Selections	24
Type PCG Pump Coupling Guard Quick Selections - Spacer Couplings	25
Type SCG Spacer Coupling Guard - Quick Selections	25
Type CCG Close-Coupled Coupling Guard - Quick Selections	26
Type CFCG Close-Coupled/Fluid Coupling Guard - Quick Selections	26
Orange Peel Guards at Work	27

Orange Peel Guards

Orange Peel Guard's patented trim-and-fit design revolutionizes equipment guard convenience and value, providing the job-site safety you want without the expense and long lead times of custom engineered guards. Because Orange Peel guards are sized to your overall application, they can be installed in three easy steps: make three simple measurements using dimensioned trim lines, make quick trim cuts, then simply fit the hardware. In less than an hour, Orange Peel can have you up and running.

Safety Comes First

Orange Peel guards comply with OSHA, ASME and ANSI standards, and most other guards don't. Look for a Safety Orange guard, gaps no greater than 0.250" (6 mm) and ANSI Z535.4 compliant warning labels. Plus, our distributors can do a safety assessment to recommend modifications, labeling and retrofits to upgrade your guard safety program.



Low Initial Cost

Save more than 50% over custom alternatives, using standard Orange Peel guards.

Maintenance Convenience Saves Time and Money

Orange Peel Guard's hinged guards open quickly by removing fasteners and "peeling" open the guard halves for coupling lubrication, inspection and maintenance.

Type CCG, MCG & PCG Never Dent, Rust or Need Painting

High-impact polyethylene plastic, the same material used in truck bed liners, is extremely tough and durable. Supplied in solid Safety Orange, with all stainless steel hardware, Orange Peel guards are ideal for harsh environments and virtually eliminate all guard maintenance.

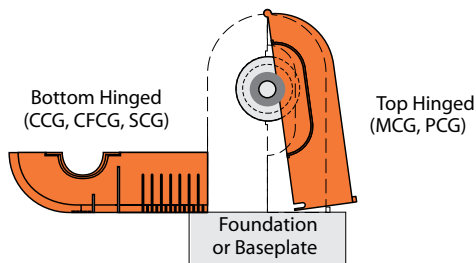

Availability Now

Orange Peel guards are available through an extensive local distributor inventory and original equipment manufacturers. Visit www.rexnord.com to locate a distributor near you.

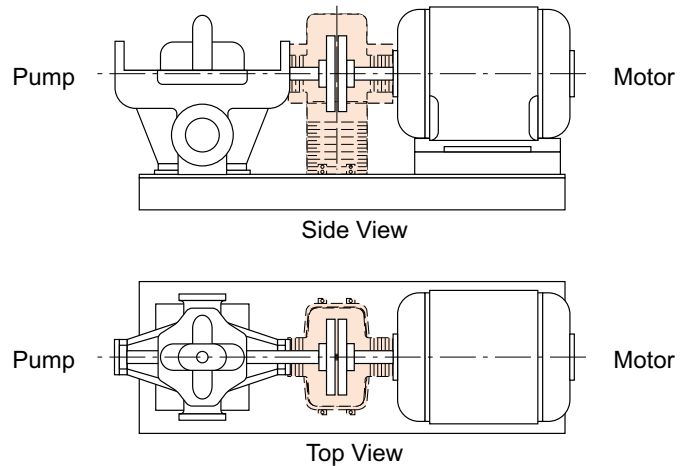

Optional Pedestal for High Base-to-Centerline Applications

Just add a pedestal, risers or a high base to the guard.

Lowest Lifetime Cost

A low initial cost, reduced maintenance costs, superior convenience and assured safety compliance make Orange Peel guards an unbeatable value.

3-Year Heavy Duty Warranty

Orange Peel is backed by the industry's first standard 3-year warranty, providing full protection.

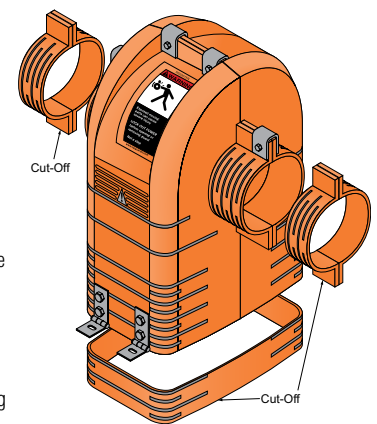

Available in Polyethylene and Metal Types



Type MCG Polyethylene Guards (Low Cost)

Close-Coupled Coupling Applications
 3 sizes (05-25)
 Diameters to 9.63" (245 mm)
 High-Impact Polyethylene
 Molded Safety Orange, Yellow or White
 Stainless Steel Hardware
 Radial Vents
 Molded ANSI Warning Labels
 Optional Risers
 -40°F to 170°F (-40°C to 77°C)
 Hinged Access for Maintenance
 Availability from Stock



Type CCG Polyethylene Guards

Close-Coupled Coupling Applications
 5 sizes (10-50)
 Diameters to 18.5" (470 mm)
 High-Impact Polyethylene Plastic
 Molded Safety Orange
 Stainless Steel Hardware
 Radial Vents
 Standard ANSI Warning Labels
 Optional Pedestal & High Base (30-50)
 -40°F to 170°F (-40°C to 77°C)
 Hinged Access for Maintenance
 Availability from Stock



Type CFCG Metal Guards

Close-Coupled & Fluid Coupling Applications
 5 sizes (30-70)
 Diameters to 30" (762 mm)
 Steel Body/Aluminum Extensions
 Powder-Coated Safety Orange
 Stainless Steel Hardware
 Axial Vents
 Standard ANSI Warning Labels
 Optional Pedestal Base & High Base
 -40°F to 300°F (-40°C to 149°C)
 Hinged Access for Maintenance
 Availability from Stock



Type SCG Aluminum Guards

Spacer Coupling Applications
 3 sizes (30-50)
 Diameters to 18.5" (470 mm)
 Aluminum Components
 Powder-Coated Safety Orange
 Aluminum Hardware
 Radial Vents
 Standard ANSI Warning Labels
 Optional Pedestal & High Base
 -40°F to 300°F (-40°C to 149°C)
 Hinged Access for Maintenance
 Availability from Stock



Type PCG Polyethylene Pump Guards

Pump Spacer Coupling Applications
 Most Standard ANSI and ISO Pumps
 Diameters up to 6.38" (162 mm)
 High-Impact Polyethylene
 Molded Safety Orange and Yellow
 Powder-Coated Leg Kits
 Stainless Steel Fasteners
 Axial Vents
 Standard ANSI Warning Labels
 -40°F to 170°F (-40°C to 77°C)
 Hinged Access for Maintenance
 Availability from Stock



Type LSG Aluminum Guards

Line Shaft Applications
 7 sizes (10-70)
 Diameters to 15" (381 mm)
 Lengths to 96" (2438 mm)
 Aluminum Components
 Optional Galvanized Mounting Legs
 Optional End Caps
 Powder-Coated Safety Orange
 Optional ANSI Warning Labels
 -40°F to 300°F (-40°C to 149°C)
 Availability from Stock

Guard Types and Accessories

Type MCG – Polyethylene Guards

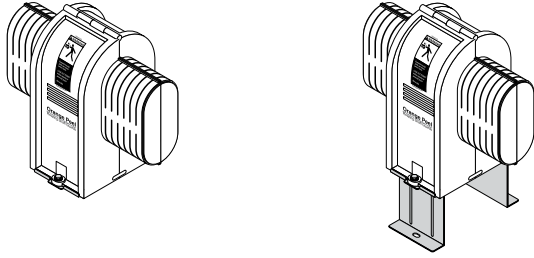

GUARD
pages 10 and 11

GUARD w/RISER SET
page 11

Type CCG – Polyethylene Guards

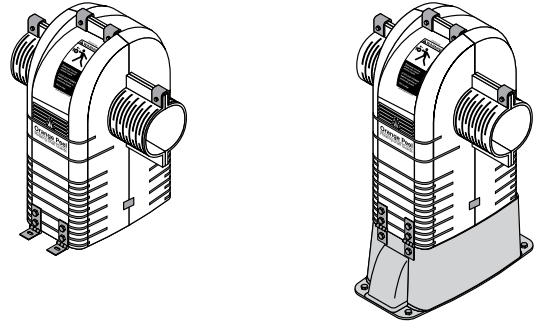

GUARD
pages 12 and 13

GUARD w/PEDESTAL
page 13

Type PCG – Polyethylene Guards

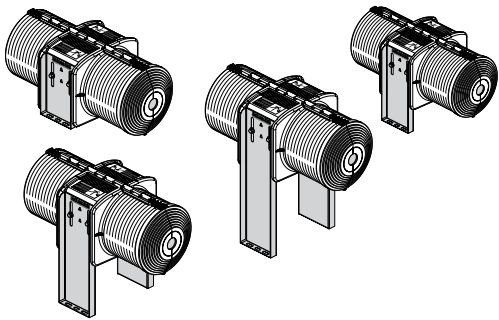

GUARD w/STD. BASE and w/LEG KIT
pages 14 and 15

Type CFCG – Steel/Aluminum Guards

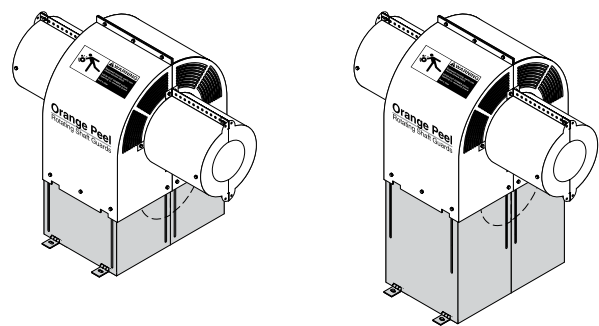

GUARD w/STD. BASE
pages 16 and 17

GUARD w/PEDESTAL BASE
page 17

Type SCG – Aluminum Guards

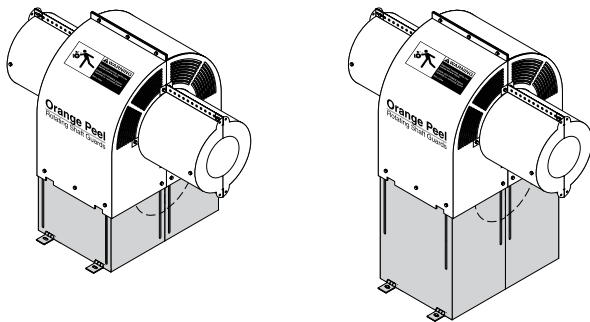

GUARD w/STD. BASE
pages 18 and 19

GUARD w/PEDESTAL BASE
page 19

Type CFCG – Steel/Aluminum Guards

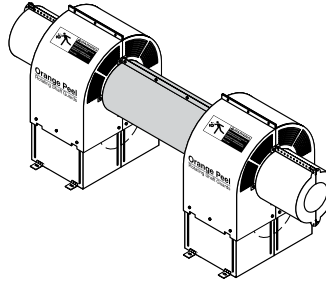

GUARDS w/CENTER MEMBER
page 17

Type LSG – Aluminum Guards

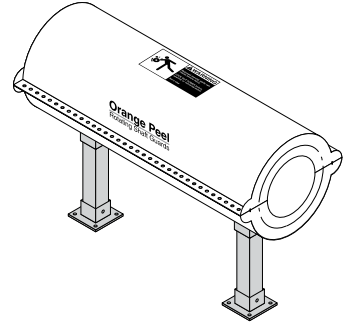

GUARD w/LEGS
pages 20 and 21

All Types – Safety Labels



ANSI Z535.4
page 8



ISO 3864
page 8

All Types – Stainless Steel



INSPECTION PORT KIT
page 7

Type CCG/CFCG/SCG Guards – Steel

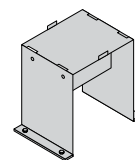

HIGH BASE
page 7

Guard Options

High Base

- The High Base will elevate the guard by dimension "T" below.
- High Base construction is powder-coated steel.

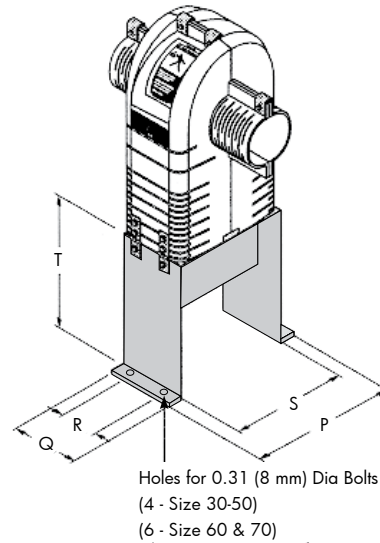

Type CCG, CFCG and SCG Optional High Base

Dimensions (in)

Guard Size	P	Q	R	S	T	Part Number	Wt (lb)
30	18.00	8.00	3.88	15.50	12.00	2924281	11
40	21.50	10.50	6.00	19.25	15.00	2924282	20
50	26.50	13.25	7.38	23.25	18.00	2924283	34
60	28.85	18.00	13.00	26.85	20.00	2924284	59
70	36.85	23.00	18.00	34.85	22.00	2924285	109

Dimensions (mm)

Guard Size	P	Q	R	S	T	Part Number	Wt (kg)
30	441	203	99	394	305	2924281	5.0
40	546	267	152	489	381	2924282	9.1
50	673	337	187	591	457	2924283	15.4
60	733	457	330	682	508	2924284	26.8
70	936	584	457	885	559	2924285	49.4

Inspection Port Kit

Flat black stainless steel Inspection Port adds visual, strobe or infrared inspection to any existing guard. It is simply added by using a hole saw and the supplied fasteners.

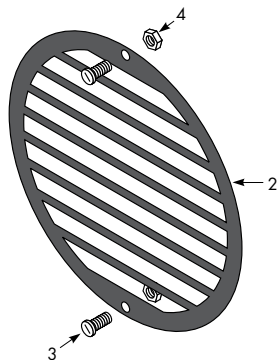

Part #2923662 2.0"/50 mm Guard Sizes 10-20

Part #2923663 3.5"/90 mm Guard Sizes 30-70

Weight = 0.3 lb (0.14 kg)

Safety Labels



ANSI Z535.4



ISO 3864

Size	Description	ANSI Part Numbers ①	ISO Part Numbers ①
1.88" x 3.75"/48 x 95 mm	Vertical Safety Label-Coupling & Shaft	2924286	2924292
1.88" x 3.75"/48 x 95 mm	Vertical Safety Label-Belt & Chain	2924287	2924293
3" x 6"/75 x 150 mm	Vertical Safety Label-Coupling & Shaft	2924288	2924294
3" x 6"/75 x 150 mm	Vertical Safety Label-Belt & Chain	2924289	2924295
6" x 3"/150 x 75 mm	Horizontal Safety Label-Coupling & Shaft	2924290	2924296
6" x 3"/150 x 75 mm	Horizontal Safety Label-Belt & Chain	2924291	2924297

① Excludes Falk® Type HF26; refer to Rexnord. Also available in packs of 100.

Spare Hardware

Type/Size	Description	Part Number
Type CCG and LSG, Sizes 10-20	6 mm Stainless Steel Fastener Kit	2924298
Type CCG and LSG, Sizes 30-50	8 mm Stainless Steel Fastener Kit	2924299
Type CFCG, Sizes 30-70	8 mm Stainless Steel Fastener Kit	2924300
Type SCG, Sizes 30-50	5/16" Aluminum Fastener Kit	2924301
Type CCG, Sizes 10-20	Stainless Steel Clip Kit	2924302
Type CCG, Sizes 30-50	Stainless Steel Clip Kit	2924303
Type CCG, Sizes 10-20	Stainless Steel Hinge Kit	2924304
Type CCG, Sizes 30-50	Stainless Steel Hinge Kit	2924305

Model-Series Description

Orange Peel Guard Nomenclature

CCG

TYPE

MCG (Motor Coupling Guard)
 PCG (Pump Coupling Guard)
 CCG (Close-Coupled Coupling Guard)
 CFCG (Close-Coupled/Fluid Coupling Guard)
 SCG (Spacer Coupling Guard)
 LSG (Line Shaft Guard)

20

SIZE

05
 Thru
 80

00

CODE

00 (Guard)
 01-24
 25-74 (Pedestal,
 Base, Riser, Leg)
 75-99 (Extension,
 End Cap)

A

MODEL

A, B, etc.
 S (Special)

OA

CHARACTERISTICS

OA (Orange/ANSI)
 YI (Yellow/ISO)
 WA (White/ANSI)
 7L (Long)
 M (Medium)
 S (Short)

Orange Peel Guard Accessories Nomenclature

RSG

TYPE

RSG (Rotating Shaft Guard-Accessory/Part)

0001

CODE

0001-0019 (Safety/Logo Labels)
 0020-0039 Hinges
 0040-0059 Clips/Splices
 0060-0079 Fasteners
 0080-0099 Packaging
 0100-0159 Literature
 0160-0179 Inspection Ports
 0180-9999 Open

A

MODEL

A, B, etc.
 S (Special)

EN

CHARACTERISTICS

EN (English)

Guard Assemblies

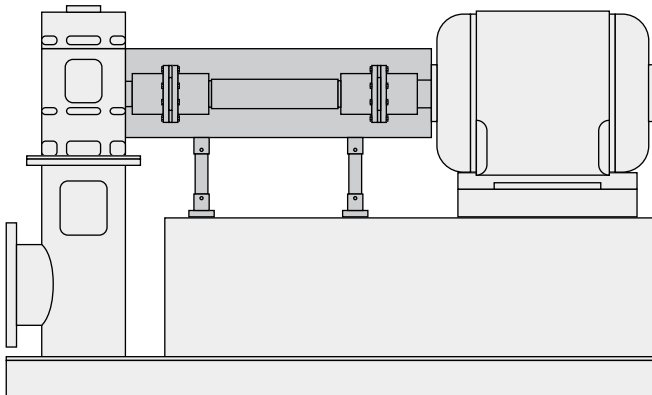

Type LSG with Disc Coupling

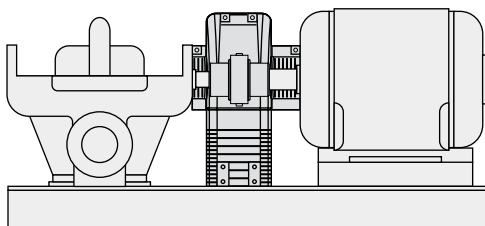

Type CCG with Elastomer Coupling

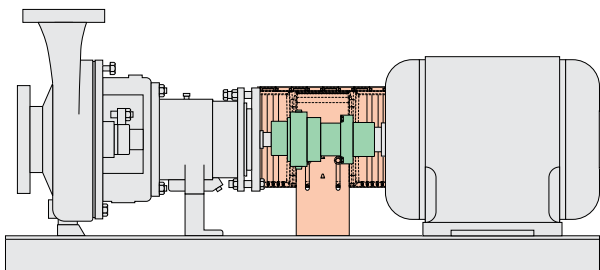

Type PCG with Elastomer Coupling

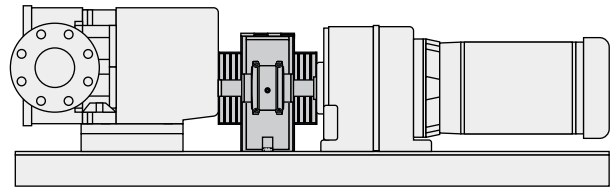

Type MCG with Grid Coupling

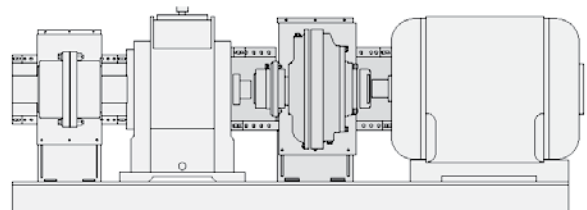

Type CFCG and SCG with Fluid & Gear Coupling

Type MCG Polyethylene Guards

Motor (Gearmotor) Coupling Guard/Selection

1. Determine application dimensions.

- A _____
- B₁ _____ (trimming dimension)
- B₂ _____ (trimming dimension)
- C _____
- D₁ _____
- D₂ _____
- E _____
- F _____
- RPM _____

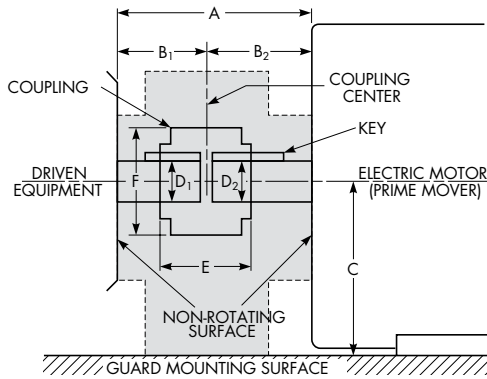

Considerations:

- Install and operate Orange Peel products in conformance with applicable local and national safety codes, and as stated in the supplied Orange Peel Installation and Maintenance Manual.
- The user must make a determination of guard size and suitability for a specific use (visit www.rexnord.com/opguards for detailed specifications – guards suitable for non-catastrophic containment). Refer all special requirements to Rexnord.
- If application dimensions are preliminary, leave allowances in your selection. Maintain design clearances for couplings that are not symmetrical.
- Allowable temperature range is -40°F to 170°F (-40°C to 77°C), up to 200°F (94°C) intermittent.
- Etched safety labels are molded into the guard halves. ANSI Z535.4 (2924286) and ISO 3864 (2924292) safety labels can also be purchased for guard application.
- High-vibratory applications may need additional guard support.

2. Compare application dimensions to guard sizing dimensions in the product selection tables. If the application dimension exceeds the sizing dimension, select the next largest size.

See Quick Selection tables on pages 23 and 24.

Application dimension:

- Select the smallest guard size where application dimension E is less than E_{max}.
- Verify that application Dimension F is less than F_{max}. Maximum RPM is 3600.
- Verify that application Dimension A falls between the A_{max} and A_{min}.
- Verify that application Dimensions B₁ and B₂ fall between B_{max} and B_{min}. The coupling guard can be mounted off center, if clearances permit. Coupling hubs can be overhung to increase application Dimension B.
- Verify that application Dimension C falls between C_{max} and C_{min}. If not, verify that application Dimension C is less than C_{max} w/riser, and add appropriate riser to the guard selection. (Part numbers are shown on **page 11**.)
- Verify that application Dimensions D₁ and D₂ are less than D_{max} w/key. Coupling hubs can protrude into the guard extensions, if the diameter is less than D_{max} w/o key.

3. Contact a Rexnord distributor to purchase the selected guard, using the part numbers indicated.

Product Selection Table (in)

Guard Size	A ① Max	A ② Min	B ① Max	B ② Min	C Max	C Min	C Max with Riser			D Max w/Key	D Max w/o Key	E Max	F Max	ANSI Safety Orange		ISO Safety Yellow		Sanitary White	
							Guard Part No.	Wt (lb)	Guard Part No.					Wt (lb)	Guard Part No.	Wt (lb)			
05	8.50	4.00	4.25	2.00	5.25	3.00	6.75	8.25	9.75	1.38	1.75	3.50	4.00	2924200	1.3	2924203	1.3	2924206	1.3
15	12.50	5.81	6.25	2.91	7.50	4.50	9.50	11.50	13.50	2.13	2.63	5.00	6.38	2924201	3.1	2924204	3.1	2924207	3.1
25	18.50	8.38	9.25	4.19	11.50	7.00	14.50	17.50	20.50	3.88	4.88	7.25	9.63	2924202	8.1	2924205	8.1	2924208	8.1

Product Selection Table (mm)

Guard Size	A ① Max	A ② Min	B ① Max	B ② Min	C Max	C Min	C Max with Riser			D Max w/Key	D Max w/o Key	E Max	F Max	ANSI Safety Orange		ISO Safety Yellow		Sanitary White	
							Guard Part No.	Wt (kg)	Guard Part No.					Wt (kg)	Guard Part No.	Wt (kg)			
05	216	102	108	51	133	71	171	210	248	38	44	89	102	2924200	0.59	2924203	0.59	2924206	0.59
15	318	148	159	74	191	112	241	292	343	55	67	127	162	2924201	1.41	2924204	1.41	2924207	1.41
25	470	213	235	106	292	178	368	445	521	100	124	184	245	2924202	3.69	2924205	3.69	2924208	3.69

① Includes maximum allowable gaps.

② Without end caps (with end caps, add 0.375"/10 mm per side, allow 0.750" hub to machine clearance).

Type MCG Polyethylene Guards

Motor (Gearmotor) Coupling Guard/Selection

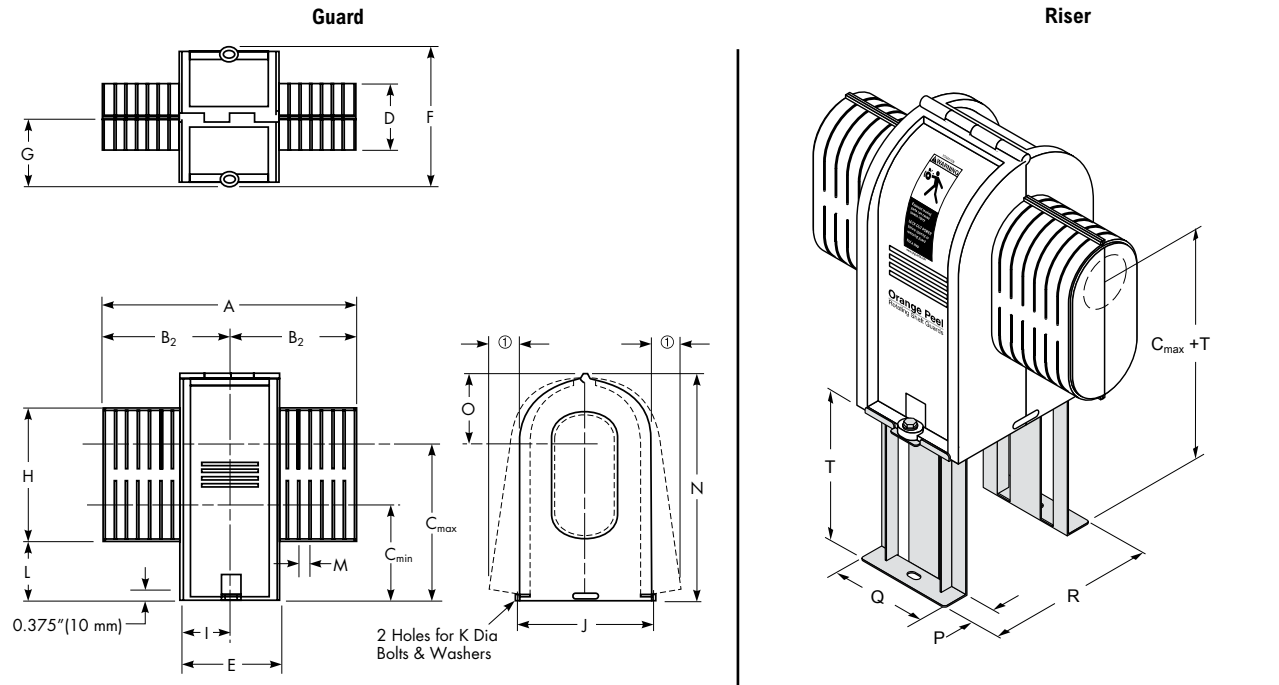

NOTES:

- Guard includes 2 molded halves, assembled with a 304/A2 SS pin, 4 optional snap-fit end cap halves, (2) 304/A2 SS fender washers and installation manual.
- Riser mounting slot is in the same location as the guard.
- Nominal material thickness is 0.13" (3.3 mm) Size 05, 0.16" (4.1 mm) Size 15, 0.19" (4.8 mm) Size 25.
- Polyethylene guards cannot be painted.
- ① Requires a side clearance in each direction for guard removal or installation. Guard bottom can be removed, if mounted on a solid surface.

Optional Riser

Guard	Height Adder (T)		Part Number		Weight	
	(in)	(mm)	Steel	304 SS	(lb)	(kg)
05	1.50	38	2924218	2924227	0.7	0.3
	3.00	76	2924221	2924230	1.0	0.5
	4.50	114	2924224	2924233	1.4	0.6
15	2.00	51	2924219	2924228	0.9	0.4
	4.00	102	2924222	2924231	1.3	0.6
	6.00	152	2924225	2924234	1.9	0.9
25	3.00	76	2924220	2924229	1.8	0.8
	6.00	152	2924223	2924232	2.8	1.3
	9.00	229	2924226	2924235	3.6	1.6

Guard Dimensions (in)

Guard Size	A	B	C [Ⓜ] Max	C Min	C Max+T			D	E	F	G	H	I	J	K	L	M	N	O	P	Q	R
05	8.00	4.00	5.25	3.00	6.75	8.25	9.75	2.75	4.00	7.38	3.69	5.50	2.00	6.00	0.31	1.37	0.50	8.57	3.32	1.50	4.00	7.44
15	12.00	6.00	7.50	4.50	9.50	11.50	13.50	3.75	5.81	9.94	4.97	7.20	2.91	8.56	0.31	2.40	0.50	12.02	4.52	1.50	5.81	9.94
25	18.00	9.00	11.50	7.00	14.50	17.50	20.50	6.00	8.38	13.62	6.81	10.63	4.19	12.25	0.31	3.94	0.50	18.13	6.63	2.00	8.38	12.56

Guard Dimensions (mm)

Guard Size	A	B	C [Ⓜ] Max	C Min	C Max+T			D	E	F	G	H	I	J	K	L	M	N	O	P	Q	R
05	203	102	133	71	171	210	248	70	102	188	94	140	51	154	8	35	12.5	218	84	38	102	189
15	305	152	191	112	241	292	343	95	148	252	126	183	74	217	8	61	12.5	305	115	38	148	252
25	457	229	292	178	368	445	521	152	213	346	173	270	106	311	8	100	12.5	461	168	51	213	319

② Add Riser (T), to increase C_{max} dimension.

Type CCG Polyethylene Guards

Close-Coupled Coupling Guard/Selection

1. Determine application dimensions.

- A _____
- B₁ _____ (trimming dimension)
- B₂ _____ (trimming dimension)
- C _____ (trimming dimension)
- D₁ _____
- D₂ _____
- E _____
- F _____
- RPM _____

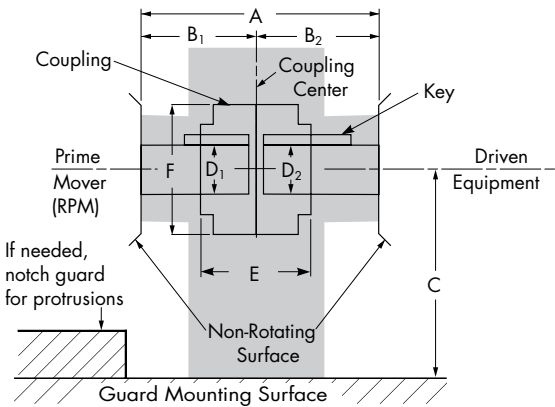

Considerations:

- Install and operate Orange Peel products in conformance with applicable local and national safety codes, and as stated in the supplied Orange Peel Installation and Maintenance Manual.
- The user must make a determination of guard size and suitability for a specific use (visit www.rexnord.com/opguards for detailed specifications – guards suitable for non-catastrophic containment). Refer all special requirements to Rexnord.
- If application dimensions are preliminary, leave allowances in your selection. Maintain design clearances for couplings that are not symmetrical.
- Allowable temperature range is -40°F to 170°F (-40°C to 77°C), up to 200°F (94°C) intermittent.
- ANSI Z535.4 English warning labels are supplied as standard. Optional ISO 3864 symbol-based safety labels can be supplied, for international (non-U.S.) requirements.
- High-vibratory applications may need additional guard support.

2. Compare application dimensions to guard sizing dimensions in the product selection tables. If the application dimension exceeds the sizing dimension, select the next largest size.

See Quick Selection table on page 26.

Application dimension:

- Select the smallest guard size where application Dimension E is less than E_{max}.
- Verify that application Dimension F is less than F_{max}. Maximum RPM is 3600.
- Verify that application Dimension A falls between the A_{max} and A_{min}.
- Verify that application Dimensions B₁ and B₂ fall between B_{max} and B_{min}. The coupling guard can be mounted off center, if clearances permit.
- Verify that application Dimension C falls between C_{max} and C_{min}. If not, verify that application Dimension C is less than C_{max} w/pedestal, and add a pedestal to the guard selection.
- Verify that application Dimensions D₁ and D₂ are less than D_{max} w/key. Coupling hubs can protrude into the guard extensions if the diameter is less than D_{max} w/o key.

3. Contact a Rexnord distributor to purchase the selected guard, using the part numbers indicated.

Product Selection Table (in)

Guard Size	A ① Max	A ② Min	B ① Max	B ② Min	C Max	C Min	C Max w/Pedestal	D Max w/Key	D Max w/o Key	E Max	F Max	Guard		Pedestal	
												Part No.	Wt (lb)	Part No.	Wt (lb)
20	12.50	5.50	6.25	2.75	11.00	3.00	17.00	2.13	2.63	5.00	7.50	2923201	4.5	2924312	2.0
30	18.50	8.00	9.25	4.00	13.50	4.00	20.50	3.00	3.63	7.00	11.00	2923202	11.0	2924239	3.5
40	23.50	10.50	11.75	5.25	16.50	4.50	24.50	4.00	4.50	9.50	14.50	2923203	18.0	2924240	7.0
50	27.50	13.25	13.75	6.63	19.50	5.25	28.50	5.00	6.00	12.25	18.50	2923204	23.5	2924241	11.5

Product Selection Table (mm)

Guard Size	A ① Max	A ② Min	B ① Max	B ② Min	C Max	C Min	C Max w/Pedestal	D Max w/Key	D Max w/o Key	E Max	F Max	Guard		Pedestal	
												Part No.	Wt (kg)	Part No.	Wt (kg)
20	318	140	159	70	279	76	432	54	67	127	191	2923201	2.0	2924312	0.9
30	470	203	235	102	343	102	521	76	92	178	279	2923202	5.0	2924239	1.6
40	597	267	298	133	419	114	622	102	114	241	368	2923203	8.2	2924240	3.2
50	699	337	349	168	495	133	724	127	152	311	470	2923204	10.7	2924241	5.2

① Includes maximum allowable gaps.

② Verify that the coupling does not interfere with the foundation.

Type CCG Polyethylene Guards

Close-Coupled Coupling Guard/Selection

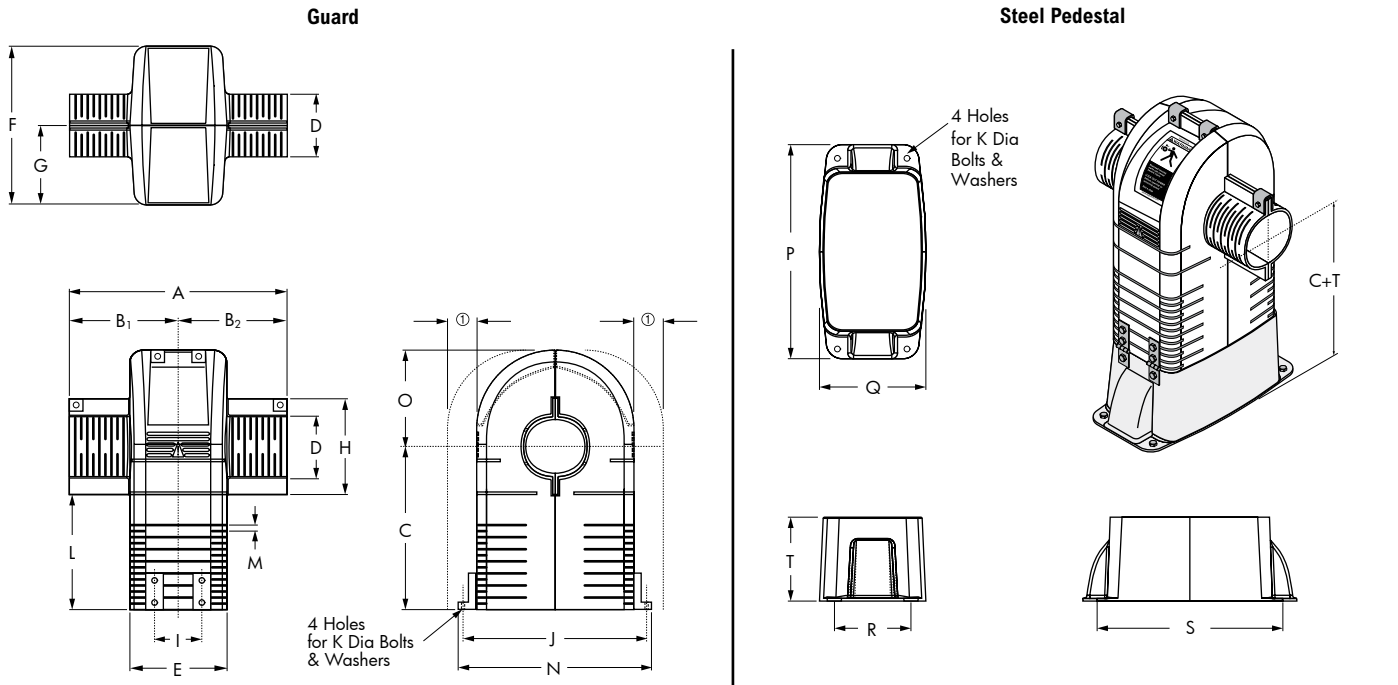

NOTES:

- Extension clips are not required for B1/B2 minimum condition. Maintain a minimum of 3 clips, Sizes 30-50.
- Nominal material thickness is 0.19" (4.8 mm) Size 20/30, 0.250" (6.4 mm) Size 40/50.
- Polyethylene guards cannot be painted.
- ① Requires a minimum 1/2 shaft diameter clearance in each direction for guard removal or installation.

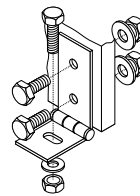

HINGE DETAIL

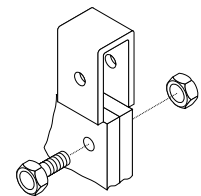

CLIP DETAIL

Guard Dimensions (in)

Guard Size	A	B	C	C+T	D	E	F	G	H	I	J	K	L	M	N ^②	O	P	Q	R	S	T
20	12.00	6.00	11.00	17.00	4.00	5.50	9.50	4.75	6.00	1.25	11.15	0.25	8.00	0.50	12.00	5.75	12.25	6.13	4.50	11.25	6.00
30	18.00	9.00	13.50	20.50	5.00	8.00	13.25	6.63	8.00	3.88	15.50	0.31	9.50	0.50	16.75	8.00	18.00	9.00	5.50	15.50	7.00
40	23.00	11.50	16.50	24.50	6.00	10.50	17.00	8.50	9.00	6.00	19.25	0.31	12.00	0.50	20.50	10.00	21.50	12.00	8.00	19.50	8.00
50	27.00	13.50	19.50	28.50	7.50	13.25	21.00	10.50	10.50	7.38	23.25	0.31	14.25	0.50	24.50	12.00	26.50	14.50	10.00	24.50	9.00

Guard Dimensions (mm)

Guard Size	A	B	C	C+T	D	E	F	G	H	I	J	K	L	M	N ^②	O	P	Q	R	S	T
20	305	152	279	432	102	140	241	121	152	32	283	6	203	12.5	305	146	311	156	114	286	152
30	457	229	343	521	127	203	337	168	203	99	394	8	241	12.5	425	203	457	229	140	394	178
40	584	292	419	622	152	267	432	216	229	152	489	8	305	12.5	521	254	546	305	203	495	203
50	686	343	495	724	191	337	533	267	267	187	591	8	362	12.5	622	305	673	368	254	622	229

② Hinges can be reverse mounted to minimize this dimension.

Type PCG Polyethylene Guards

(Pump Spacer) Coupling Guard/Selection

1. Determine application dimensions.

- A _____
- B₁ _____ (trimming dimension)
- B₂ _____ (trimming dimension)
- C _____ (select proper leg kit)
- D₁ _____
- D₂ _____
- E _____
- F _____
- RPM _____

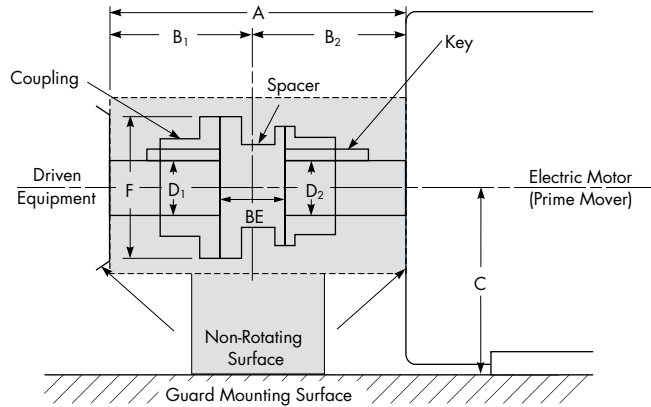

Considerations:

- Install and operate Orange Peel products in conformance with applicable local and national safety codes, and as stated in the supplied Orange Peel Installation and Maintenance Manual.
- The user must make a determination of guard size and suitability for a specific use (visit www.rexnord.com/opguards for detailed specifications – guards suitable for non-catastrophic containment). Refer all special requirements to Rexnord.
- If application dimensions are preliminary, leave allowances in your selection. Maintain design clearances for couplings that are not symmetrical.
- Allowable temperature range is -40°F to 170°F (-40°C to 77°C), up to 200°F (94°C) intermittent.
- Etched safety labels are molded into the guard halves. ANSI Z535.4 English warning labels are supplied as standard. Optional ISO 3864 symbol-based safety labels can be supplied, for international (non-U.S.) requirements.
- High-vibratory applications may need additional guard support.

2. Compare application dimensions to guard sizing dimensions in the product selection tables. If the application dimension exceeds the sizing dimension, select type SCG. **See Quick Selection tables on page 25.**

Application dimension:

- Select the smallest guard size where application Dimension F is less than F_{max}. Maximum RPM is 3600.
- Verify that application Dimension A falls between the A_{max} and A_{min}.
- Verify that application Dimensions B₁ and B₂ fall between B_{max} and B_{min}. The coupling guard can be mounted off center, if clearances permit.
- Verify that application Dimension C falls between C_{max} and C_{min}. Add appropriate leg kit to the guard selection. (Part numbers are shown on **page 15**.)
- Verify that application Dimensions D₁ and D₂ are less than D_{max} w/key. Coupling hubs can protrude into the guard extensions if the diameter is less than D_{max} w/o key.

3. Contact a Rexnord distributor to purchase the selected guard, using the part numbers indicated.

Product Selection Table (in)

Guard Size	A Max ①	A Min ②	B Max ①	B Min ②	C Min ③	C Max ③	D Max w/Key	D Max w/o Key	F Max	ANSI Safety Orange		ISO Safety Yellow	
										Guard Part No.	Wt (lb)	Guard Part No.	Wt (lb)
15	18.50	8.00	9.25	3.50	4.50	20.50	5.88	6.38	6.38	2926597	3.26	2926598	3.26

Product Selection Table (mm)

Guard Size	A Max ①	A Min ②	B Max ①	B Min ②	C Min ③	C Max ③	D Max w/Key	D Max w/o Key	F Max	ANSI Safety Orange		ISO Safety Yellow	
										Guard Part No.	Wt (lb)	Guard Part No.	Wt (lb)
15	469	203	235	89	114	521	149	162	162	2926597	1.48	2926598	1.48

- ① Includes maximum allowable gaps without end cap.
- ② Without end cap; with end cap add up to 1.13" (28.7 mm) each, depending on cap trim dimension.
- ③ Select proper leg kit for application centerline requirement from **page 15**.

Type PCG Polyethylene Guards

(Pump Spacer) Coupling Guard/Selection

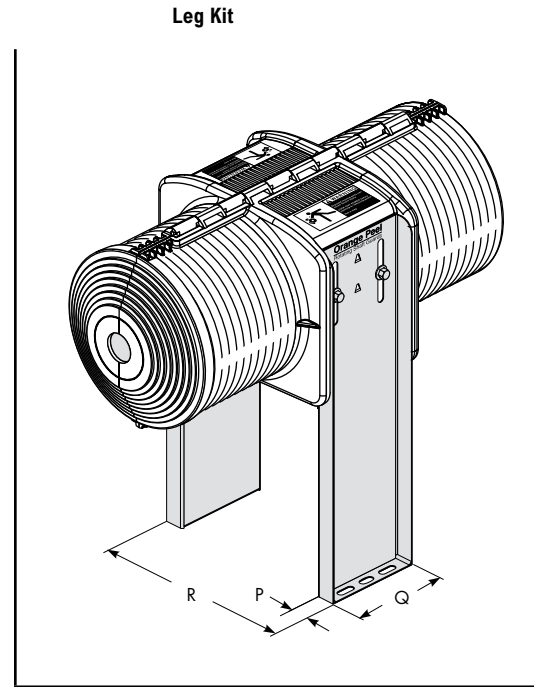
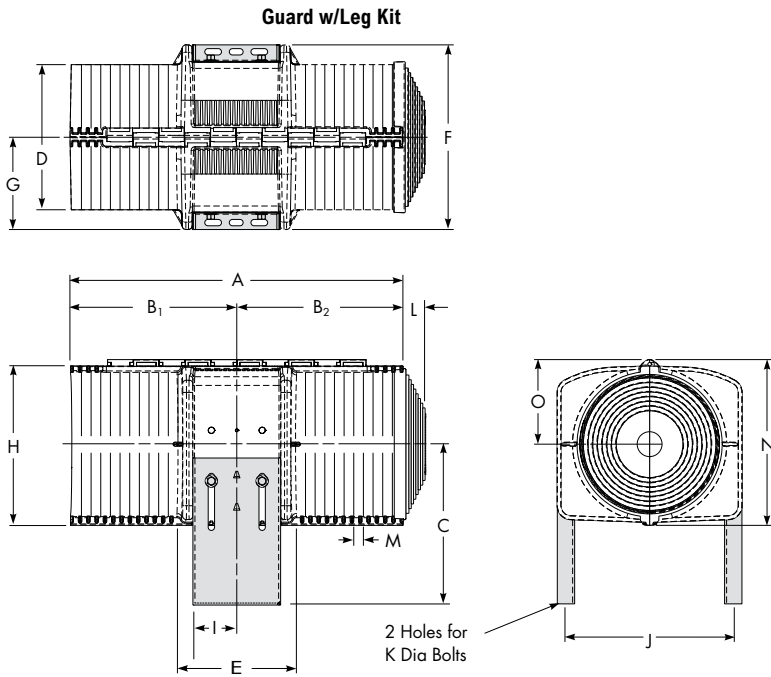

NOTES:

- Guard includes 2 molded halves, assembled with a 304/A2 SS pin, snap-fit end cap (pump side), and installation manual.
- Nominal material thickness is 0.13" (3.3 mm).
- Polyethylene guards cannot be painted.
- Guard requires a side clearance in each direction for guard removal or installation.

Leg Kits

Size	Part Number	Centerline Dimension				Weight	
		(in)		(mm)		(lb)	(kg)
		C Min	C Max	C Min	C Max		
15	2926599	4.50	8.50	114	216	2.4	1.1
	2926700	8.50	12.50	216	318	3.6	1.6
	2926701	12.50	16.50	318	419	5.6	2.5
	2926702	16.50	20.50	419	521	8.6	3.4

NOTE: Select Leg Kit where measured "C" dimension is between the "C" min-max range shown.

Guard Dimensions (in)

Guard Size	A	B	C Min	C Max ①	D	E	F	G	H	I	J	K	L	M	N	O	P	Q	R	S
15	18.00	9.00	4.50	20.50	8.00	7.00	10.00	5.00	8.75	3.00	9.25	0.31	1.13	0.50	9.00	4.50	0.94	4.63	10.00	1.38

Guard Dimensions (mm)

Guard Size	A	B	C Min	C Max ①	D	E	F	G	H	I	J	K	L	M	N	O	P	Q	R	S
15	457	229	114	521	203	178	254	127	222	76	235	8	28.7	13	229	114	24	117	254	35

① Select proper leg kit for application centerline requirement.

Type CFCG Metal Guards

Close-Coupled/Fluid Coupling Guard/Selection

1. Determine application dimensions.

- A _____
- B₁ _____ (trimming dimension)
- B₂ _____ (trimming dimension)
- C _____ (adjustment dimension)
- D₁ _____
- D₂ _____
- E _____
- F _____
- RPM _____

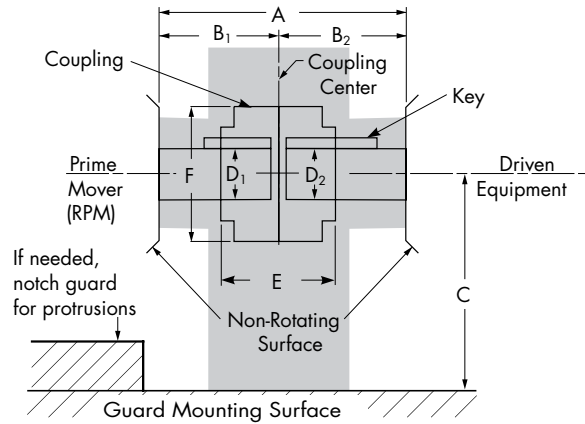

Considerations:

- Install and operate Orange Peel products in conformance with applicable local and national safety codes, and as stated in the supplied Orange Peel Installation and Maintenance Manual.
- The user must make a determination of guard size and suitability for a specific use (visit www.rexnord.com/opguards for detailed specifications – guards suitable for non-catastrophic containment). Refer all special requirements to Rexnord.
- If application dimensions are preliminary, leave allowances in your selection. Maintain design clearances for couplings that are not symmetrical.
- Allowable temperature range is -40°F to 300°F (-40°C to 149°C).
- ANSI Z535.4 English warning labels are supplied as standard. Optional ISO 3864 symbol-based safety labels can be supplied, for international (non-U.S.) requirements.
- High-vibratory applications may need additional guard support.

2. Compare application dimensions to guard sizing dimensions in the product selection tables. If the application dimension exceeds the sizing dimension, select the next largest size.

See Quick Selection table on page 26.

Application dimension:

- Select the smallest guard size where application Dimension E is less than E_{max}.
- Verify that application Dimension F is less than F_{max}. Maximum RPM is 3600.
- Verify that application Dimension A falls between the A_{max} and A_{min}.
- Verify that application Dimensions B₁ and B₂ fall between B_{max} and B_{min}. The coupling guard can be mounted off center, if clearances permit.
- Verify that application Dimension C falls between C_{max} and C_{min}. If not, verify that application Dimension C is less than C_{max} w/pedestal, and add a pedestal to the guard selection. Contact Rexnord for high-base option.
- Verify that application Dimensions D₁ and D₂ are less than D_{max} w/key. Coupling hubs can protrude into the guard extensions if the diameter is less than D_{max} w/o key.

3. Contact a Rexnord distributor to purchase the selected guard using the part numbers indicated. Complete CFCG Guard Assembly = 1 Guard Body + 1 Base (Standard or Pedestal) + 0, 1 or 2 Extensions (as required).

Product Selection Table (in)

Guard Size	A Max ①	A Min	B Max ①	B Min	C Max	C Min	C ②	C Max w/ Pedestal	D Max w/Key	D Max w/o Key	E Max	F Max	Guard Body Part No.	Wt (lb)	Standard Base Part No.	Wt (lb)	Extension w/Cap Part No.	Wt (lb)	Pedestal Base Part No.	Wt (lb)
30	22.50	8.00	11.25	4.00	13.50	7.50	8.00	19.50	4.50	5.50	6.50	11.00	2923600	8	2923606	6	2923612	4	2923618	11
40	29.00	10.50	14.50	5.25	16.50	9.00	10.75	24.00	6.00	7.50	9.00	14.50	2923601	17	2923607	11	2923613	6	2923619	20
50	35.75	13.25	17.88	6.63	19.50	10.50	12.50	28.50	7.75	9.50	11.25	18.50	2923602	31	2923608	18	2923614	8	2923620	34
60	44.50	18.00	22.25	9.00	22.00	12.00	14.50	32.00	9.50	11.50	16.00	22.00	2923603	58	2923609	30	2923615	11	2923621	59
70	56.50	23.00	28.25	11.50	24.50	13.50	18.50	35.50	12.00	15.00	21.00	30.00	2923604	114	2923610	56	2923616	18	2923622	109
80	66.50	28.00	33.25	14.00	29.50	16.50	22.00	42.50	14.00	17.50	26.00	40.00	2923605	242	2923611	96	2923617	24	2923623	189

Product Selection Table (mm)

Guard Size	A Max ①	A Min	B Max ①	B Min	C Max	C Min	C ②	C Max w/ Pedestal	D Max w/Key	D Max w/o Key	E Max	F Max	Guard Body Part No.	Wt (kg)	Standard Base Part No.	Wt (kg)	Extension w/Cap Part No.	Wt (kg)	Pedestal Base Part No.	Wt (kg)
30	572	203	286	102	343	191	203	495	114	140	165	279	2923600	4	2923606	3	2923612	2	2923618	5
40	737	267	368	133	419	229	273	610	152	191	229	368	2923601	8	2923607	5	2923613	3	2923619	9
50	908	337	454	168	495	267	312	724	197	241	286	470	2923602	14	2923608	8	2923614	4	2923620	15
60	1130	457	565	229	559	305	368	813	241	292	406	559	2923603	26	2923609	14	2923615	5	2923621	27
70	1435	584	718	292	622	343	470	902	305	381	533	762	2923604	52	2923610	25	2923616	8	2923622	49
80	1689	711	845	356	749	419	559	1080	356	445	660	1016	2923605	110	2923611	44	2923617	11	2923623	86

① Includes maximum allowable gaps.

② Minimum C dimension, at D_{max} w/o key, to fully open guard halves.

Type CFCG Metal Guards

Close-Coupled/Fluid Coupling Guard/Selection

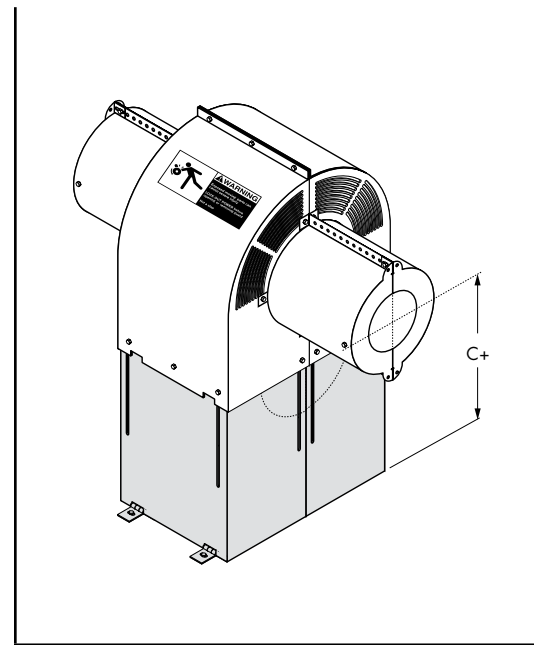
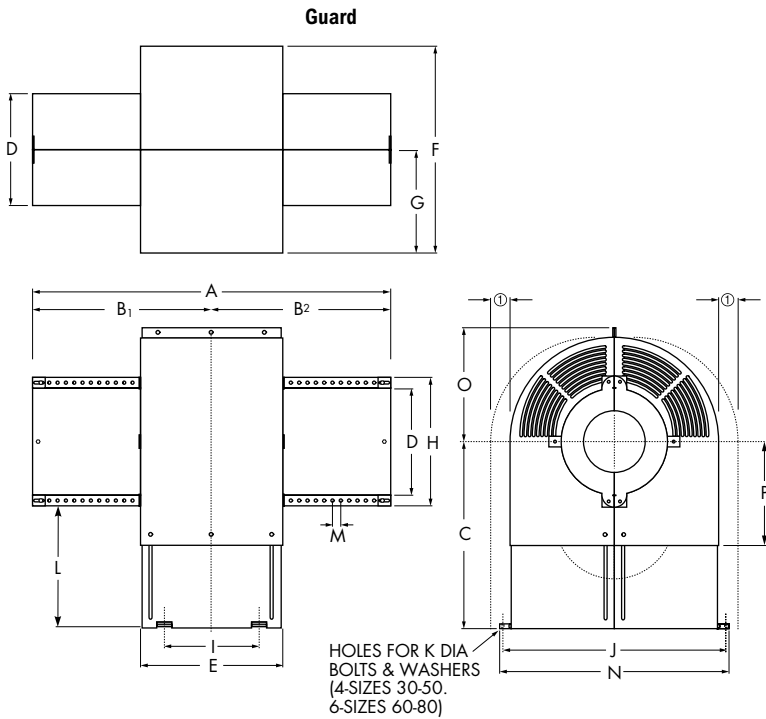

Custom Options
 Floating and Universal shaft guards: Add appropriate length Type LSG section and center member bracket kit part number 2924273.

NOTES:

- Nominal material thickness is 0.075" (1.91 mm) Size 30-50, 0.105" (2.67 mm) Size 60-80.
- Powder-coated guards can be painted.
- Sizes 30-50 have two hinges per side. Sizes 60, 70 and 80 have three hinges per side, center hinge is at the guard mid point.
- ① Requires a minimum 1/2 shaft diameter clearance in each direction for guard removal or installation.

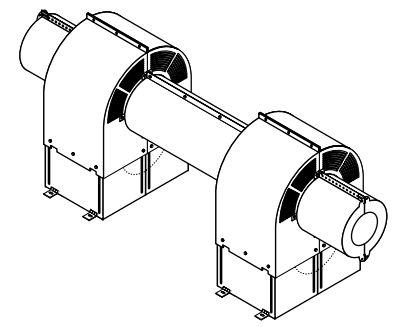

Guard Dimensions (in)

Guard Size	A	B	C	C + T	D	E	F	G	H	I ②	J	K	L	M	N	O	P	T
30	22.00	11.00	13.50	19.50	7.00	8.00	13.88	6.94	10.00	3.88	15.50	0.31	8.50	1.00	16.98	8.44	7.50	6.00
40	28.50	14.25	16.50	24.00	9.00	10.50	17.63	8.82	12.00	6.00	19.25	0.31	10.50	1.00	20.73	10.32	9.00	7.50
50	35.25	17.63	19.50	28.50	11.00	13.25	21.63	10.82	14.00	7.38	23.25	0.31	12.50	1.00	24.73	12.32	10.50	9.00
60	44.00	22.00	22.00	32.00	13.00	18.00	25.00	12.50	16.00	6.20	26.85	0.31	14.00	1.00	28.04	14.00	12.00	10.00
70	56.00	28.00	24.50	35.50	16.50	23.00	33.00	16.50	19.50	8.63	34.85	0.31	14.75	1.00	36.04	18.00	13.50	11.00
80	66.00	33.00	29.50	42.50	19.00	28.00	43.00	21.50	22.00	11.50	44.85	0.31	18.50	1.00	46.04	23.00	16.50	13.00

Guard Dimensions (mm)

Guard Size	A	B	C	C + T	D	E	F	G	H	I ②	J	K	L	M	N	O	P	T
30	559	279	343	495	178	203	353	176	254	99	394	8	216	25	431	214	191	152
40	724	362	419	610	229	267	448	224	305	152	489	8	267	25	527	262	229	191
50	895	448	495	724	279	337	549	275	356	187	591	8	318	25	628	313	267	229
60	1118	559	559	813	330	457	635	318	406	165	682	8	356	25	712	356	305	254
70	1422	711	622	902	419	584	838	419	495	229	885	8	375	25	915	457	343	279
80	1676	838	749	1080	483	711	1092	546	559	292	1139	8	470	25	1169	584	419	330

② I is the distance between hinge centers (Sizes 30-50 have two hinges per side. Sizes 60, 70 and 80 have 3 hinges per side, with the center hinge at the guard mid point).

Type SCG Aluminum Guards

Spacer Coupling Guard/Selection

1. Determine application dimensions.

- A _____
- B₁ _____ (trimming dimension)
- B₂ _____ (trimming dimension)
- C _____ (adjustment dimension)
- D₁ _____
- D₂ _____
- E _____
- F _____
- RPM _____

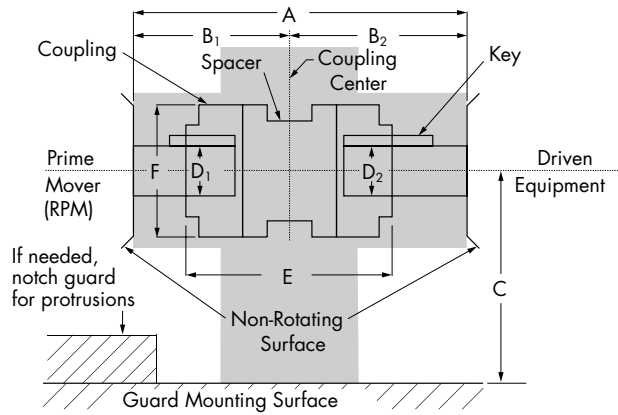

Considerations:

- Install and operate Orange Peel products in conformance with applicable local and national safety codes, and as stated in the supplied Orange Peel Installation and Maintenance Manual.
- The user must make a determination of guard size and suitability for a specific use (visit www.rexnord.com/opguards for detailed specifications – guards suitable for non-catastrophic containment). Refer all special requirements to Rexnord.
- If application dimensions are preliminary, leave allowances in your selection. Maintain design clearances for couplings that are not symmetrical.
- Allowable temperature range is -40°F to 300°F (-40°C to 149°C).
- ANSI Z535.4 English warning labels are supplied as standard. Optional ISO 3864 symbol-based safety labels can be supplied, for international (non-U.S.) requirements.
- High-vibratory applications may need additional guard support.
- Aluminum guards and fasteners are non-sparking (hinges are stainless steel).

2. Compare application dimensions to guard sizing dimensions in the product selection tables. If the application dimension exceeds the sizing dimension, select the next largest size.

See Quick Selection table on page 25.

Application dimension:

- Select the smallest guard where application dimension F is less than F_{max}, at E_{max} width, or less than D_{max} w/o key. Maximum RPM is 3600. Contact Rexnord for higher speeds.
- Verify that application Dimension A falls between the A_{max} and A_{min}.
- Verify that application Dimensions B₁ and B₂ fall between B_{max} and B_{min}. The coupling guard can be mounted off center, if clearances permit.
- Verify that application Dimension C falls between C_{max} and C_{min}. If not, verify that application Dimension C is less than C_{max} w/pedestal, and add a pedestal to the guard selection. Contact Rexnord for high-base option.
- Verify that application Dimensions D₁ and D₂ are less than D_{max} w/key.

3. Contact a Rexnord distributor to purchase the selected guard using the part numbers indicated. Complete SCG Guard Assembly = 1 Guard Body + 1 Base (Standard or Pedestal) + 2 Extensions.

Product Selection Table (in)

Guard Size	A Max ①	A Min	B Max ①	B Min	C Max	C Min	C ②	C Max w/ Pedestal	D Max w/Key	D Max w/o Key	E Max	F Max	Guard Body Part No.	Wt (lb)	Standard Base Part No.	Wt (lb)	Extension w/Cap Part No.	Wt (lb)	Pedestal Base Part No.	Wt (lb)
30	30.50	8.00	15.25	4.00	13.50	7.50	10.50	19.50	7.75	9.50	6.50	11.00	2924242	8	2924245	6	2923614	8	2924248	11
40	37.00	10.50	18.50	5.25	16.50	9.00	13.00	24.00	9.50	11.50	9.00	14.50	2924243	17	2924246	11	2923615	11	2924249	20
50	46.75	13.25	23.38	6.63	19.50	10.50	19.00	28.50	13.00	15.00	11.25	18.50	2924244	31	2924247	18	2923616	18	2924250	34

Product Selection Table (mm)

Guard Size	A Max ①	A Min	B Max ①	B Min	C Max	C Min	C ②	C Max w/ Pedestal	D Max w/Key	D Max w/o Key	E Max	F Max	Guard Body Part No.	Wt (kg)	Standard Base Part No.	Wt (kg)	Extension w/Cap Part No.	Wt (kg)	Pedestal Base Part No.	Wt (kg)
30	775	203	387	102	343	191	267	495	197	241	165	279	2924242	4	2924245	3	2923614	4	2924248	5
40	940	267	470	133	419	229	330	610	241	292	229	368	2924243	8	2924246	5	2923615	5	2924249	9
50	1187	337	594	168	495	267	483	724	330	381	286	470	2924244	14	2924247	8	2923616	8	2924250	15

① Includes maximum allowable gaps.

② Minimum C dimension, at D_{max} w/o key, to fully open guard halves.

Type SCG Aluminum Guards

Spacer Coupling Guard/Selection

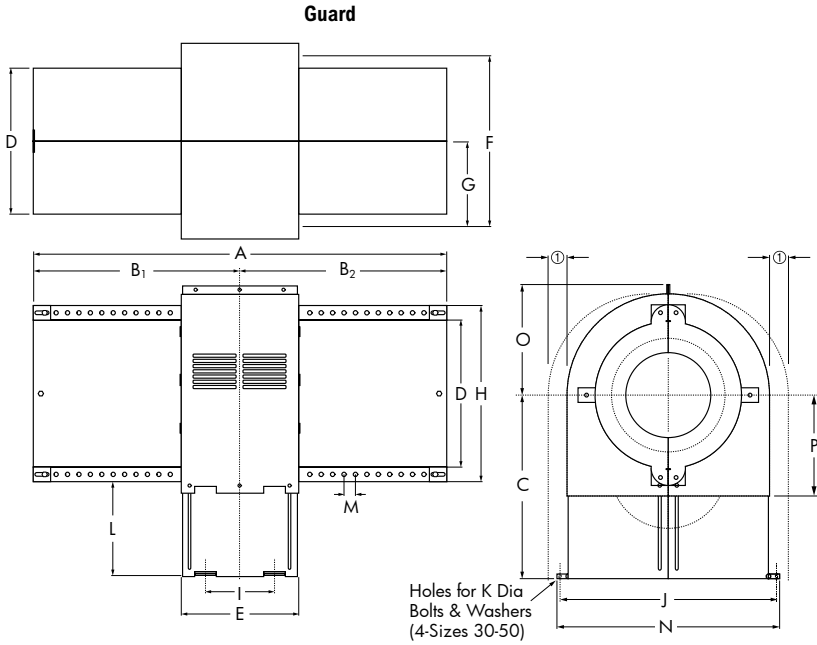

Pedestal Base

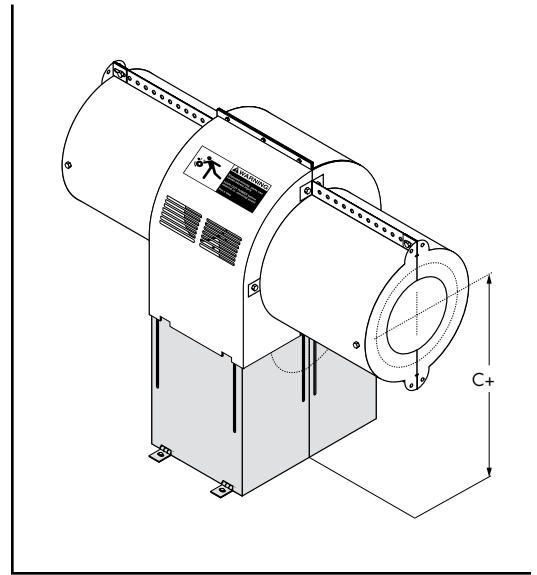

NOTES:

- Non-sparking aluminum components and fasteners (hinges are stainless steel).
- Nominal material thickness is 0.075" (1.91 mm) Sizes 30-50.
- Powder-coated guards can be painted.
- Sizes 30-50 have 2 hinges per side.
- ① Requires a minimum 1/2 shaft diameter clearance in each direction for guard removal or installation.

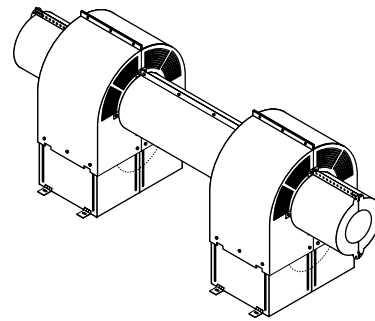

Custom Options

Floating and Universal shaft guards: Add appropriate length Type LSG section and center member bracket kit part number 2924273.

Guard Dimensions (in)

Guard Size	A	B	C	C + T	D	E	F	G	H	I	J	K	L	M	N	O	P	T
30	30.00	15.00	13.50	19.50	11.00	8.00	13.88	6.94	14.00	3.88	15.50	0.31	6.50	1.00	16.98	8.44	7.50	6.00
40	36.50	18.25	16.50	24.00	13.00	10.50	17.63	8.82	16.00	6.00	19.25	0.31	8.50	1.00	20.73	10.32	9.00	7.50
50	46.25	23.13	19.50	28.50	16.50	13.25	21.63	10.82	19.50	7.38	23.25	0.31	8.50	1.00	24.73	12.32	10.50	9.00

Guard Dimensions (mm)

Guard Size	A	B	C	C + T	D	E	F	G	H	I	J	K	L	M	N	O	P	T
30	762	381	343	495	279	203	353	176	356	99	394	8	165	25	431	214	191	152
40	927	464	419	610	330	267	448	224	406	152	489	8	216	25	527	262	229	191
50	1175	588	495	724	419	337	549	275	495	187	591	8	216	25	628	313	267	229

Type LSG Aluminum Guards

Line Shaft Guard/Selection

1. Determine application dimensions.

- A _____ (trimming dimension)
- C _____ (trimming dimension)
- D _____
- RPM _____

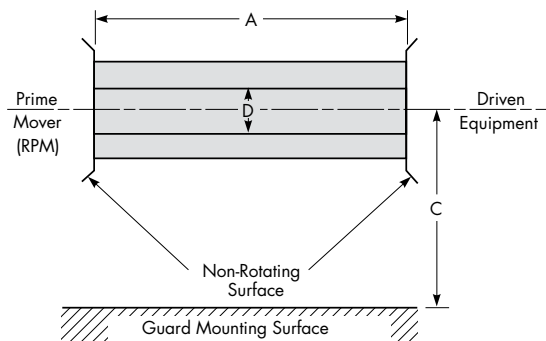

Considerations:

- Install and operate Orange Peel products in conformance with applicable local and national safety codes, and as stated in the supplied Orange Peel Installation and Maintenance Manual.
- The user must make a determination of guard size and suitability for a specific use (visit www.rexnord.com/opguards for detailed specifications – guards suitable for non-catastrophic containment). Refer all special requirements to Rexnord.
- If application dimensions are preliminary, leave allowances in your selection. Maintain design clearances for couplings that are not symmetrical.
- Allowable temperature range is -40°F to 300°F (-40°C to 149°C).
- ANSI Z535.4 English warning labels are supplied as standard. Optional ISO 3864 symbol-based safety labels can be supplied, for international (non-U.S.) requirements.
- High-vibratory applications may need additional guard support.
- Aluminum guards and fasteners are non-sparking (leg kits are galvanized steel).

2. Compare application dimensions to guard sizing dimensions in the product selection tables. If the application dimension exceeds the sizing dimension, select the next largest size.

Application dimension:

- Select the smallest guard where application Dimension D is less than D_{max}. Maximum RPM is 3600.
- Verify that application Dimension A is less than A_{max}.
- Determine if guard will be equipment or base-mounted.
- Verify that application Dimension C falls between C_{max} and C_{min}, if the guard is mounted with the optional leg kit.

3. Contact a Rexnord distributor to purchase the selected guard length using the part numbers indicated. Complete LSG Guard Assembly = 2 Guard Halves + Optional End Cap/s, Fastener Set, and/or Optional Leg Kit/s. The CFCG center member brackets are used with CFCG guard assemblies.

Product Selection Table (in)

Guard Size	A Max ①	C ②		D Max w/o Key	Guard Half Part Numbers						End Cap		Leg Kit		CFCG CM Bracket	
		Max	Min		96 Inch	Wt (lb)	48 Inch	Wt (lb)	24 Inch	Wt (lb)	Part No.	Wt (lb)	Part No.	Wt (lb)	Part No.	Wt (lb)
10	96.50	37.50	9.00	1.75	2924251	6.9	2924258	3.5	2924265	1.7	2924274	0.1	2924272	11.9	2924273	1.2
20	96.50	38.50	10.00	3.50	2924252	10.1	2924259	5.1	2924266	2.5	2924275	0.2	2924272	11.9	2924273	1.2
30	96.50	39.50	11.00	5.50	2924253	14.3	2924260	7.2	2924267	3.6	2924276	0.3	2924272	11.9	2924273	1.2
40	96.50	40.50	12.00	7.50	2924254	17.6	2924261	8.8	2924268	4.4	2924277	0.4	2924272	11.9	2924273	1.2
50	96.50	41.50	13.00	9.50	2924255	20.8	2924262	10.4	2924269	5.2	2924278	0.5	2924272	11.9	2924273	1.2
60	96.50	42.50	14.00	11.50	2924256	24.0	2924263	12.0	2924270	6.0	2924279	0.7	2924272	11.9	2924273	1.2
70	96.50	44.25	15.75	15.00	2924257	29.6	2924264	14.8	2924271	7.4	2924280	0.9	2924272	11.9	2924273	1.2

Product Selection Table (mm)

Guard Size	A Max ①	C ②		D Max w/o Key	Guard Half Part Numbers						End Cap		Leg Kit		CFCG CM Bracket	
		Max	Min		2438 mm	Wt (kg)	1219 mm	Wt (kg)	610 mm	Wt (kg)	Part No.	Wt (kg)	Part No.	Wt (kg)	Part No.	Wt (kg)
10	2451	953	229	44	2924251	3.1	2924258	1.6	2924265	0.8	2924274	0.0	2924272	5.4	2924273	0.5
20	2451	978	254	89	2924252	4.6	2924259	2.3	2924266	1.1	2924275	0.1	2924272	5.4	2924273	0.5
30	2451	1003	279	140	2924253	6.5	2924260	3.2	2924267	1.6	2924276	0.1	2924272	5.4	2924273	0.5
40	2451	1029	305	191	2924254	8.0	2924261	4.0	2924268	2.0	2924277	0.2	2924272	5.4	2924273	0.5
50	2451	1054	330	241	2924255	9.4	2924262	4.7	2924269	2.4	2924278	0.2	2924272	5.4	2924273	0.5
60	2451	1080	356	292	2924256	10.9	2924263	5.4	2924270	2.7	2924279	0.3	2924272	5.4	2924273	0.5
70	2451	1124	400	381	2924257	13.4	2924264	6.7	2924271	3.4	2924280	0.4	2924272	5.4	2924273	0.5

① Includes maximum allowable gap.

② Using Leg Kit 2924272.

Type LSG Aluminum Guards

Line Shaft Guard/Selection

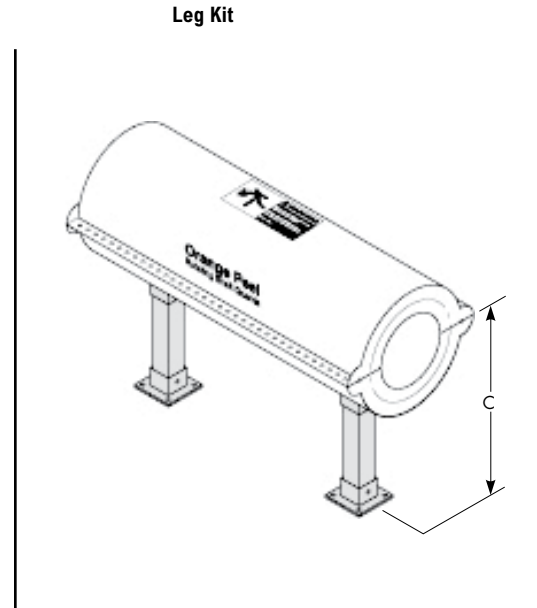
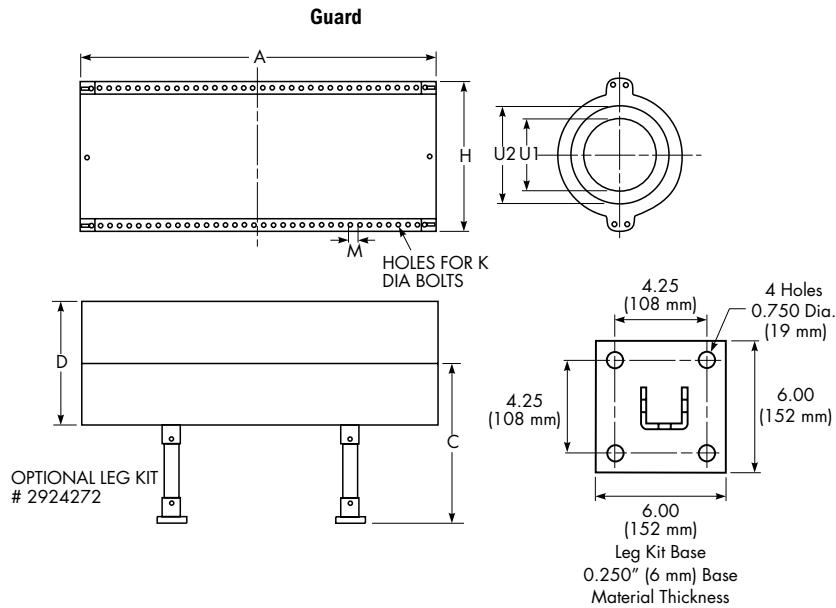

NOTES:

- Non-sparking aluminum components (guard and end caps).
- Safety labels and fasteners are optional and can be ordered separately.
- Nominal material thickness is 0.080" (2.03 mm) Sizes 10 & 20, 0.125" (3.18 mm) Sizes 30-70.
- Powder-coated guards can be painted.
- Guard can be machine-mounted, or floor-mounted, using optional Leg Kit 2924272, galvanized steel – (1 complete leg per kit)

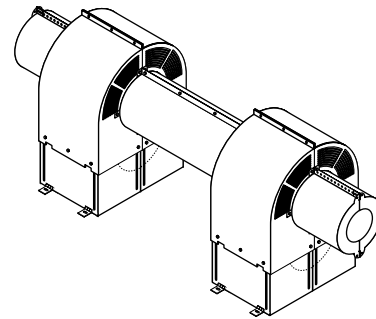

Custom Options

Floating and Universal shaft guards: Add appropriate length Type LSG section and center member bracket kit part number 2924273.

Guard Dimensions (in)

Guard Size	A	C	D	H	K	M	U1	U2
10	96.00	37.50	3.00	5.00	0.25	1.00	1.50	2.00
20	96.00	38.50	5.00	7.00	0.25	1.00	2.25	4.00
30	96.00	39.50	7.00	10.00	0.31	1.00	5.00	6.00
40	96.00	40.50	9.00	12.00	0.31	1.00	6.00	7.50
50	96.00	41.50	11.00	14.00	0.31	1.00	7.50	9.00
60	96.00	42.50	13.00	16.00	0.31	1.00	7.50	10.00
70	96.00	44.25	16.50	19.50	0.31	1.00	9.00	12.00

Guard Dimensions (mm)

Guard Size	A	C	D	H	K	M	U1	U2
10	2438	953	76	127	6	25	38	51
20	2438	978	127	178	6	25	57	102
30	2438	1003	178	254	8	25	127	152
40	2438	1029	229	305	8	25	152	191
50	2438	1054	279	356	8	25	191	229
60	2438	1080	330	406	8	25	191	254
70	2438	1124	419	495	8	25	229	305

Type VCG Metal Guards

Volume Custom-Coupling Guard/Quote Request Form

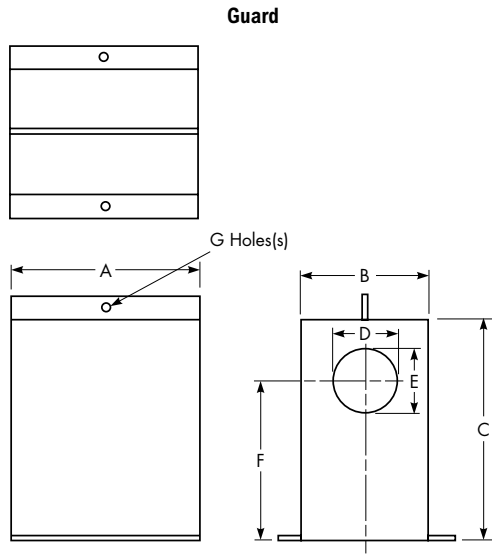

Optional Features

Standard

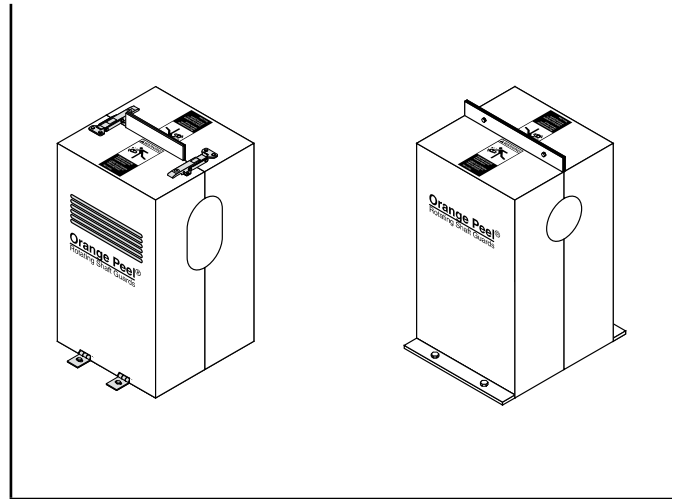

Type VCG Description: (2 Symmetrical Halves)

AxBxC-DxE-F-G/H/I/J/K/L/M

0.00x0.00x0.00-0.00x0.00-0.00-0.000/X/X/X/X/X

PN:VCG

H

- Steel
- Stainless Steel
- Aluminum
- I
- Unpainted
- Safety Orange
- Safety Yellow

J

- No Safety Label
- ANSI Safety Label
- ISO Safety Label

K

- Optional Cooling/Inspection Vent

L

- Optional SS Base Hinge(s)

M

- Optional SS Locking Lasp(s)

Circle Material

- ST
- SS
- AL
- UP
- SO
- SY
- NS
- AS
- IS
- IV
- BH
- LL

- 0-8" **A** = 16 Gauge w/1-0.270" **G** Hole (1/4" or 6 mm fasteners)
- 8-16" **A** = 16 Gauge w/2-0.334" **G** Hole (5/16" or 8 mm fasteners)
- 16-36" **A** = 14 Gauge w/3-0.334" **G** Hole (5/16" or 8 mm fasteners)
- 36-48" **A** = 12 Gauge w/4-0.334" **G** Hole (5/16" or 8 mm fasteners)

Fill in Dimensions:

A _____ **D** _____

B _____ **E** _____

C _____ **F** _____

Quantities = _____, _____, _____ guards

Shipment 3-4 Weeks/FOB Rexnord

From:

Name: _____

Company: _____

Address: _____

Phone: _____

Fax: _____

E-mail: _____

Purchaser must determine guard suitability for the intended application (guards suitable for non-catastrophic containment). Guard must be installed to maintain maximum gaps/safe distances as specified in ANSI/ASME B15.1-2000.

Type MCG Polyethylene Guards - NEMA Motor Quick Selections

Quick selections are based on the manufacturer's catalog; close-coupled coupling diameter and width, with straight bored hubs. Verify all selection dimensions. Maximum RPM is 3600.

Check B, C, D, E & F Selection Dimensions:

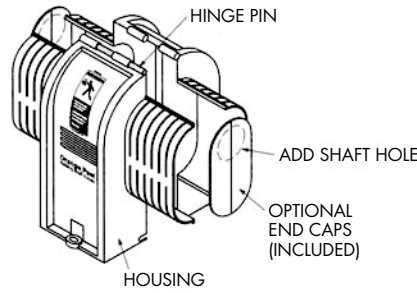
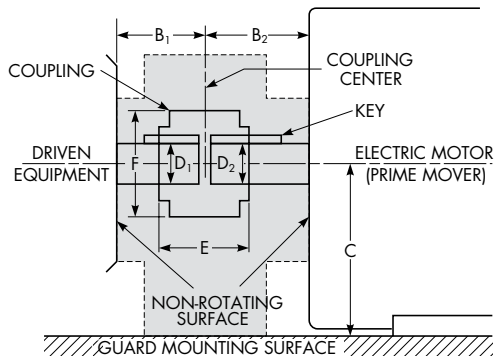

Guards are supplied with molded ISO safety labels. ISO & ANSI decals are also available. (2924286, 2924292)

Features: Standard polyethylene guards provide safety compliance, economy and maintenance convenience. By trimming the guard extensions, MCG Coupling Guards can accommodate a wide range of equipment and shaft coupling types.

Motor			Guard Selection		Dimensions (in) / Coupling Size							Optional Riser		
Frame	Shaft Dia	C	ANSI Safety Orange Part Number	Sanitary White Part Number	B Max	B Min	C Max	C Min	D Max	E Max	F Max	Height	Part Number	
48	0.500	3.00	2924200	2924206	4.25	2.00	5.25	3.00	1.38	3.50	4.00	1.50	2924218	
56	0.625	3.50	2924201 Size 05	Rexnord Wrapflex	Sizes:	5R	-	-	-	-	-	3.00	2924221	
143T	0.875	3.50		Falk Steelflex	Sizes:	1020	1030	-	-	-	-	4.50	2924224	
145T	0.875	3.50		Lovejoy Jaw	Sizes:	70	75	90	95	99	100	1.50 ①	2924227 ①	
182T	1.125	4.50		Woods Sureflex	Sizes:	3	4	5	6	-	-	3.00 ①	2924230 ①	
184T	1.125	4.50		Martin Chain	Sizes:	4012	4016	-	-	-	-	4.50 ①	2924233 ①	
213T	1.375	5.25		Rexnord Omega	Sizes:	E2	-	-	-	-	-	-	-	-
215T	1.375	5.25	-	-	-	-	-	-	-	-	-	-	-	
182T	1.125	4.50	2924202 Size 15	2924207	6.25	2.91	7.50	4.50	2.13	5.00	6.38	2.00	2924219	
184T	1.125	4.50		Rexnord Wrapflex	Sizes:	10	20	-	-	-	-	4.00	2924222	
213T	1.375	5.25		Falk Steelflex	Sizes:	1040	1050	1060	-	-	-	6.00	2924225	
215T	1.375	5.25		Lovejoy Jaw	Sizes:	110	150	190	-	-	-	2.00 ①	2924228 ①	
254T	1.625	6.25		Woods Sureflex	Sizes:	7	8	9	-	-	-	4.00 ①	2924231 ①	
256T	1.625	6.25		Rexnord Viva	Sizes:	110	125	130	-	-	-	6.00 ①	2924234 ①	
284T	1.875	7.00		Martin Chain	Sizes:	5016	5018	6018	6020	-	-	-	-	-
284TS	1.625	7.00		AGMA Gear	Sizes:	10	15	-	-	-	-	-	-	-
286T	1.875	7.00		Rexnord Omega	Sizes:	E4	E5	E10	-	-	-	-	-	-
286TS	1.625	7.00		-	-	-	-	-	-	-	-	-	-	-
284T	1.875	7.00	2924202 Size 25	2924208	9.25	4.19	11.50	7.00	3.88	7.25	9.63	3.00	2924220	
284TS	1.625	7.00		Rexnord Wrapflex	Sizes:	30	40	-	-	-	-	6.00	2924223	
286T	1.875	7.00		Falk Steelflex	Sizes:	1070	1080	1090	-	-	-	9.00	2924226	
286TS	1.625	7.00		Lovejoy Jaw	Sizes:	225	226	-	-	-	-	3.00 ①	2924229 ①	
324T	2.125	8.00		Woods Sureflex	Sizes:	10	11	-	-	-	-	6.00 ①	2924232 ①	
324TS	1.875	8.00		Rexnord Viva	Sizes:	170	190	215	245	-	-	9.00 ①	2924235 ①	
326T	2.125	8.00		Martin Chain	Sizes:	6022	8018	8020	10018	-	-	-	-	-
326TS	1.875	8.00		AGMA Gear	Sizes:	20	25	30	-	-	-	-	-	-
				Rexnord Omega	Sizes:	E20	E30	E40	-	-	-	-	-	-
364T	2.375	9.00												
364TS	1.875	9.00												
365T	2.375	9.00												
365TS	1.875	9.00												
404T	2.875	10.00												
404TS	2.125	10.00												
405T	2.875	10.00												
405TS	2.125	10.00												
444T	3.375	11.00												
444TS	2.375	11.00												
445T	3.375	11.00												
445TS	2.375	11.00												

Guard with Motor Frame Sizes

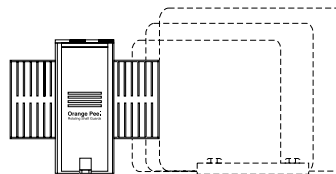

Guards for larger frame motors may require guard accessories or an alternative guard design. Please follow MCG guard selection procedure on pages 9-10.

① 304/A2 Stainless Steel.

Type MCG Polyethylene Guards - IEC Motor Quick Selections

Quick selections are based on the manufacturer's catalog; close-coupled coupling diameter and width, with straight bored hubs. Verify all selection dimensions. Maximum RPM is 3600.

Check B, C, D, E & F Selection Dimensions:

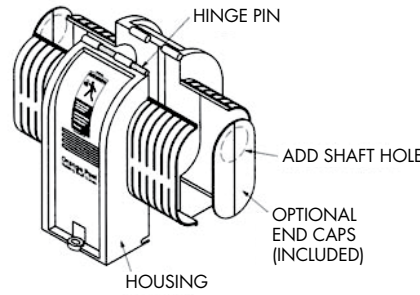
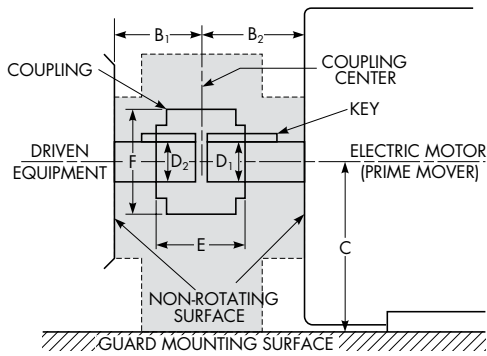

Guards are supplied with molded ISO safety labels. ISO & ANSI decals are also available. (2924286, 2924292)

Features: Standard polyethylene guards provide safety compliance, economy and maintenance convenience.

By trimming the guard extensions, MCG Coupling Guards can accommodate a wide range of equipment and shaft coupling types.

Motor			Guard Selection		Dimensions (mm) / Coupling Size							Optional Riser	
Frame	Shaft Dia	C	ANSI Safety Orange Part Number	Sanitary White Part Number	B Max	B Min	C Max	C Min	D Max	E Max	F Max	Height	Part Number
71	14	71	2924203	2924206	108	51	133	71	38	89	102	38	2924218
80	19	80	Size 05	Rexnord Wrapflex	Sizes:	5	—	—	—	—	—	76	2924221
90S	24	90		Falk Steelflex	Sizes:	1020	1030	—	—	—	—	114	2924224
90L	24	90		KTR Curved Jaw	Sizes:	14	19	24	28	—	—	38 ①	2924227 ①
100L	28	100		Woods Sureflex	Sizes:	3	4	5	6	—	—	76 ①	2924230 ①
112M	28	112		Flender N-Eupex	Sizes:	68	80	95	100	—	—	114 ①	2924233 ①
132S	38	132	—	—	—	—	—	—	—	—	—	—	—
132M	38	132	—	—	—	—	—	—	—	—	—	—	—
112M	28	112	2924204	2924207	159	74	191	112	55	127	162	51	2924219
132S	38	132	Size 15	Rexnord Wrapflex	Sizes:	10	20	—	—	—	—	102	2924222
132M	38	132		Falk Steelflex	Sizes:	1040	1050	1060	—	—	—	152	2924225
160M	42	160		KTR Curved Jaw	Sizes:	38	42	—	—	—	—	51 ①	2924228 ①
160L	42	160		Woods Sureflex	Sizes:	7	8	9	—	—	—	102 ①	2924231 ①
180M	48	180		Flender N-Eupex	Sizes:	110	125	140	160	—	—	152 ①	2924234 ①
180L	48	180	Rexnord Viva	Sizes:	110	125	130	—	—	—	—	—	—
200L	55	200 ②	Flender Gear	Sizes:	1	1.5	—	—	—	—	—	—	—
180M	48	180	2924205	2924208	235	106	292	178	100	184	245	76	2924220
180L	48	180	Size 25	Rexnord Wrapflex	Sizes:	30	40	—	—	—	—	152	2924223
200L	55	200		Falk Steelflex	Sizes:	1070	1080	1090	—	—	—	229	2924226
225S	60	225		KTR Curved Jaw	Sizes:	48	55	65	—	—	—	76 ①	2924229 ①
225M	60	225		Woods Sureflex	Sizes:	10	11	—	—	—	—	152 ①	2924232 ①
250M	70	250		Flender N-Eupex	Sizes:	180	200	225	—	—	—	229 ①	2924235 ①
280S	75	280	Rexnord Viva	Sizes:	170	190	215	245	—	—	—	—	—
280M	75	280	Flender Gear	Sizes:	2	2.5	3	—	—	—	—	—	—
315S	80	315 ②	—	—	—	—	—	—	—	—	—	—	—
315M	90	315 ②	—	—	—	—	—	—	—	—	—	—	—
355M	100	355 ②	—	—	—	—	—	—	—	—	—	—	—
355L	100	355 ②	—	—	—	—	—	—	—	—	—	—	—
400M	100	400 ②	—	—	—	—	—	—	—	—	—	—	—
400L	100	400 ②	—	—	—	—	—	—	—	—	—	—	—

Guard with Motor Frame Sizes

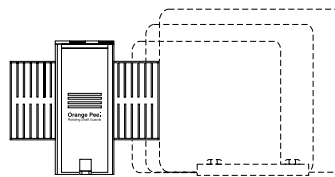

- ① 304/A2 Stainless Steel.
- ② Riser required.

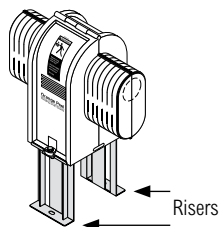

Type PCG Pump Coupling Guard Quick Selections - Spacer Couplings

Quick Selections are based on the manufacturer's catalog; coupling diameter and width. Verify all selection dimensions.

Guard Type						Coupling Type																		
PCG						Falk			Rexnord			Rexnord			Rexnord									
Size	A Max	A Min	C Max	C Min	F Max ①	Steeflex T31 (Grid)			Wrapflex R31 (Elastomer)			Series 52			Series 71 (Disc)			Omega ES (Tire)			Viva VS (Tire)			
						Size	A	B	Size	A	B	Size	A	B	Size	A	B	Size	A	B	Size	A	B	
15	18.00	8.00	20.50	4.50	6.38	1020	3.8	6.3-9.7	5	3.2	6.3-7.8	125	3.69	8.00	150	3.6	6.1-7.6	2	3.5	4.0-5.8	110	4.3	8.0-8.5	
						1030	4.2	6.7-10.5	10	3.7	6.7-10.5	162	4.34	8.50	175	4.2	6.6-8.1	3	4.0	5.0-8.0	125	4.7	8.0-8.8	
						1040	4.5	7.7-11.5	20	5.2	7.7-11.5	200	5.44	9.10	225	4.9	9.0-11.0	4	4.6	5.0-8.4	130	5.1	8.0-8.7	
						1050	5.3	9.5-12.0	30	6.0	9.5-12.0	225	5.69	10.2	333	6.0	10.2-12.2	5	5.4	5.0-8.5	170	6.6	8.0-11.04	
						1060	5.8	10.8-18.1	—	—	—	—	—	—	—	—	—	—	10	6.4	5.0-8.8	—	—	—
						1070	6.3	11.2-18.5	—	—	—	—	—	—	—	—	—	—	—	—	—	—	—	—
						—	—	—	—	—	—	—	—	—	—	—	—	—	—	—	—	—	—	—

Guard Type						Coupling Type																		
PCG						Lovejoy			TB Woods			KTR			Flender			AGMA			Dodge			
Size	A Max	A Min	C Max	C Min	F Max ①	RRS/RRC (Jaw)			Sureflex SC (Elastomer)			Rotex-ZS-DMK1 (Curved Jaw)			N-Rupex (Elastomer)			All (Gear)			Paraflex PS (Tire)			
						Size	A	B	Size	A	B	Size	A	B	Size	A	B	Size	A	B	Size	A	B	
15	18.00	8.00	20.50	4.50	6.38	90	2.5	5.1-8.6	5	3.3	5.6	48	4.1	11.8	80	3.1	6.9-8.5	1.0	4.6	6.9-8.4	40	4.3	5.3-6.8	
						95	2.5	5.5-9.0	6	4.0	5.9-7.4	55	4.7	12.5	95	3.7	7.1-8.7	1.5	6.0	7.4-8.9	50	5.3	5.5-7.0	
						99	3.1	5.6-9.1	7	4.6	6.4-7.9	65	5.3	13.1	110	4.3	7.5-10.4	—	—	—	60	6.5	5.5-12.5	
						100	3.1	6.3-9.8	8	5.5	6.9-9.6	75	6.3	14.1	140	5.5	7.9-15.0	—	—	—	—	—	—	
						110	3.8	6.9-10.4	9	6.4	7.5-13.1	—	—	—	160	6.3	9.1-15.4	—	—	—	—	—	—	
						150	4.4	7.0-10.5	—	—	—	—	—	—	—	—	—	—	—	—	—	—	—	—
						190	5.0	7.4-10.9	—	—	—	—	—	—	—	—	—	—	—	—	—	—	—	—
						225	5.6	7.9-11.4	—	—	—	—	—	—	—	—	—	—	—	—	—	—	—	—
						226	5.5	9.2-12.7	—	—	—	—	—	—	—	—	—	—	—	—	—	—	—	—
						—	—	—	—	—	—	—	—	—	—	—	—	—	—	—	—	—	—	—

① F_{max} selections are based on major diameter of coupling

Type SCG Spacer Coupling Guard - Quick Selections

Quick selections are based on the manufacturer's catalog; close-coupled coupling diameter and width. Verify all selection dimensions. Maximum RPM is 3600. Numbers in parenthesis () are in millimeters.

Guard Size	B Min-Max	C Max	D ① Max	AGMA Gear Coupling Size	Falk Steelflex Grid Size	Rexnord Wrapflex Elastomer Size	Rexnord Series 52 Disc Size	TB Woods Sureflex Elastomer Size	Rexnord Series 71 Disc Size	Rexnord Omega Tire Size	Kopflex KD 2 Disc Size	Dodge Paraflex Tire Size	Flender N-Eupex Elastomer Size
30	4.00-15.25 (102-387)	13.50 (343)	9.50 (241)	2	1050	30	125	9	350	20	153	60	160
				2-1/2	1060	40	162	10	375	30	203	70	180
				3	1070	50	225	11	412	40	253	80	200
				—	1080	60	262	12	462	50	303	90	225
				—	1090	—	312	—	—	—	—	100	—
—	—	—	—	—	—	—	350	—	—	—	110	—	
40	5.25-18.50 (133-470)	16.50 (419)	11.50 (292)	3-1/2	1100	—	375	13	512	60	353	120	250
				—	1110	—	425	14	562	70	—	—	280
				—	—	—	450	—	—	—	—	—	
50	6.63-23.38 (168-594)	19.50 (495)	15.00 (381)	4	1120	—	500	—	600	80	403	—	315
				4-1/2	1130	—	550	—	712	—	453	—	350
				—	1140	—	—	—	—	—	—	—	

① D_{max} is without key. Add a pedestal/base if C_{max} is too short. Selections are based on straight bored hubs.

Type CCG Close-Coupled Coupling Guard - Quick Selections

Quick selections are based on the manufacturer's catalog; close-coupled coupling diameter and width. Verify all selection dimensions. Maximum RPM is 3600. Numbers in parenthesis () are in millimeters.

Guard Size	B Min-Max	C Max	D ① Max	AGMA Gear Coupling Size	Falk Steelflex Grid Size	Rexnord Wrapflex Elastomer Size	Rexnord Thomas 54RD Disc Size	Rexnord Omega Tire Size	Lovejoy Straight Jaw Size	Woods Sureflex Elastomer Size	Dodge Paraflex Tire Size	KTR Curved Jaw Size	Flender N-Eupex Elastomer Size
20	2.75-6.25 (70-159)	11.00 (279)	2.13 (54)	—	1020	5	125	2	35	3	—	14	58
				—	1030	—	162	—	50	4	—	19	68
				—	—	—	200	—	70	5	—	24	80
				—	—	—	225	—	75	6	—	—	95
				—	—	—	—	—	90	—	—	—	110
				—	—	—	—	—	95	—	—	—	—
				—	—	—	—	—	99	—	—	—	—
				—	—	—	—	—	100	—	—	—	—
				1	1040	10	—	3	110	7	50	28	125
				1-1/2	1050	20	—	4	150	8	60	38	140
2	—	—	—	5	190	—	70	42	160				
—	—	—	—	—	—	—	10	—	—				
—	—	—	—	—	—	—	20	—	—				
30	4.00-9.25 (102-235)	13.50 (343)	3.00 (76)	2-1/2	1060	30	262	30	225	9	80	48	180
				—	1070	40	312	40	—	10	90	55	200
				—	1080	—	350	50	—	11	100	65	—
				—	—	—	—	—	—	110	—	—	
40	5.25-11.75 (133-298)	16.50 (419)	4.00 (102)	3	1090	50	375	60	280	12	120	75	225
				3-1/2	—	—	425	70	285	13	140	90	250
				—	—	—	450	—	295	—	—	—	280
				—	—	—	—	—	—	—	—	—	—
50	6.63-13.75 (168-349)	19.50 (495)	5.00 (1.27)	4	1100	60	500	80	—	14	160	100	315
				4-1/2	1110	70	550	—	—	—	—	110	350
				—	1120	—	—	—	—	—	—	—	—

① D_{max} includes with key. Add a pedestal/base if C_{max} is too short. Selections are based on straight bored hubs, except Dodge Paraflex, which are with bushings. Rexnord Omega selections are with inboard hubs.

Type CFCG Close-Coupled/Fluid Coupling Guard - Quick Selections

Quick selections are based on the manufacturer's catalog; close-coupled coupling diameter and width. Verify all selection dimensions. Some coupling hubs protrude into the guard extensions based on D_{max} w/o key. Maximum RPM is 3600. Numbers in parenthesis () are in millimeters.

Guard Size	B Min-Max	C Max	D ① Max	AGMA Gear Coupling Size	Falk Steelflex Grid Size	Rexnord Wrapflex Elastomer Size	Rexnord Thomas 54RD Disc Size	Rexnord Omega Tire Size	Lovejoy Straight Jaw Size	Woods Sureflex Elastomer Size	Dodge Paraflex Tire Size	Flender Rupex Pin/Bush Size	Voith/Falk (All Types) Fluid Size ②
20	4.00-11.25 (102-286)	13.50 (343)	4.50 (114)	2	1060	30	125	20	225	9	70	198	185
				2-1/2	1070	40	162	30	226	10	80	228	—
				—	1080	—	200	40	276	11	90	—	—
				—	1090	—	225	50	280	—	100	—	—
				—	—	—	262	—	—	—	110	—	—
				—	—	—	312	—	—	—	—	—	—
40	5.25-14.50 (133-368)	16.50 (419)	6.00 (152)	3	1100	50	350	60	285	12	120	252	206/235
				3-1/2	1110	—	375	70	295	13	140	285	274/270
				—	1120	—	425	—	2955	14	—	320	—
				—	—	—	—	—	3067	—	—	—	—
50	6.63-17.88 (168-454)	19.50 (495)	7.75 (197)	4	1130	60	450	80	3567	16	160	360	320/320
				4-1/2	—	70	500	—	3667	—	—	400	366/370
60	9.00-22.25 (229-565)	22.00 (559)	9.50 (241)	5	1140	80	550	100	4067	—	200	450	422/420
				5-1/2	1150	—	600	—	4567	—	—	500	487/480
				6	1160	—	—	—	—	—	—	—	—
70	11.50-28.25 (292-718)	24.50 (622)	9.50 (241)	7	1170	—	—	120	—	—	240	560	562/584
				8	1180	—	—	140	—	—	280	630	650/660
				—	1190	—	—	—	—	—	—	710	—

① D_{max} includes with key. Add a pedestal/base if C_{max} is too short. Selections are based on straight bored hubs, except Dodge Paraflex, which are with bushings. Rexnord Omega selections are with inboard hubs.

② Excludes Falk Type HF26; refer to Rexnord.

Orange Peel Guards at Work

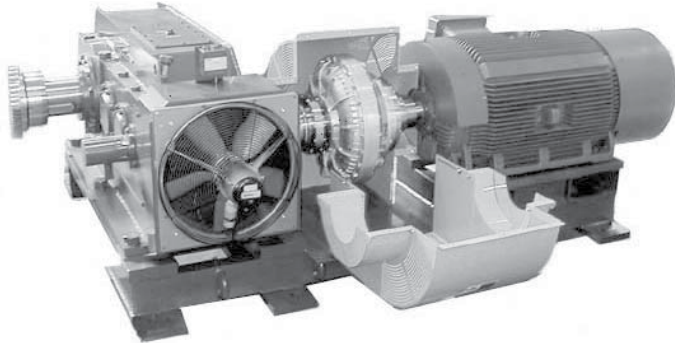

Parallel Shaft Drive & High-Speed Fluid Coupling with Type CFCG Guard

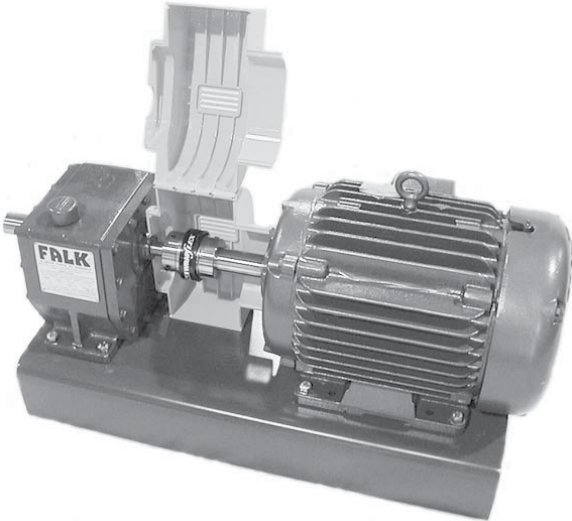

Concentric Drive & High-Speed Flexible Coupling with Type MCG Guard



Gearmotor & Low-Speed Coupling with Type MCG Guard

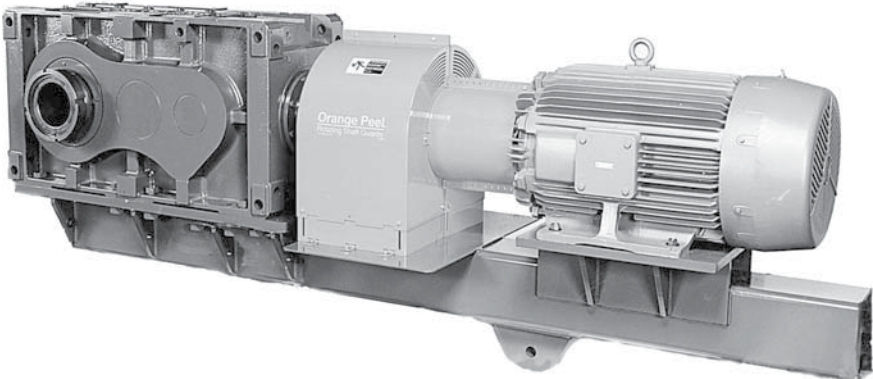

Shaft-Mounted Drive & High-Speed Coupling with Type CFCG Guard

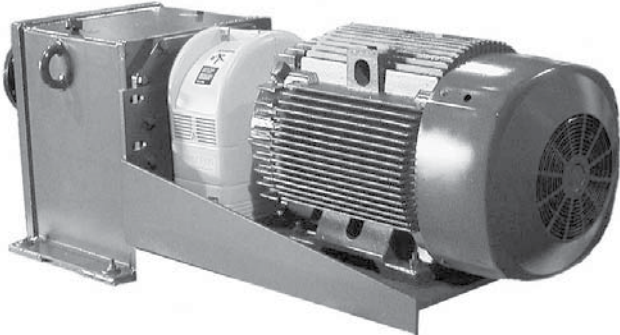

Concentric Drive & High-Speed Coupling with Type CCG Guard



866-REXNORD/866-739-6673 (Within the US)
414-643-2366 (Outside the US)
www.rexnord.com

Why Choose Rexnord?

When it comes to providing highly engineered products that improve productivity and efficiency for industrial applications worldwide, Rexnord is the most reliable in the industry. Commitment to customer satisfaction and superior value extend across every business function.

Delivering Lowest Total Cost of Ownership

The highest quality products are designed to help prevent equipment downtime and increase productivity and dependable operation.

Valuable Expertise

An extensive product offering is accompanied by global sales specialists, customer service and maintenance support teams, available anytime.

Solutions to Enhance Ease of Doing Business

Commitment to operational excellence ensures the right products at the right place at the right time.

Rexnord Corporation

Rexnord is a growth-oriented, multi-platform industrial company with leading market shares and highly trusted brands that serve a diverse array of global end markets.

Process and Motion Control

The Rexnord Process and Motion Control platform designs, manufactures, markets and services specified, highly engineered mechanical components used within complex systems where our customers' reliability requirements and the cost of failure or downtime are extremely high.

Water Management

The Rexnord Water Management platform designs, procures, manufactures and markets products that provide and enhance water quality, safety, flow control and conservation.

REXNORD

Rex® FALK Link-Belt® mar/bett® MCC BERG highfield Stearns®