

# GENERAL CATALOGUE 2023

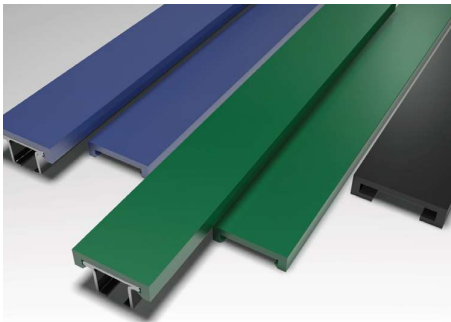



## The company



It has got a 30 years experience in the development and production of chains and components for movement and transport.

The articles in the present catalogue are designed, produced and tested in accordance with the best quality standards. Materials and productive process high technology permits to Tecom products at the world top in this field.

## The technology

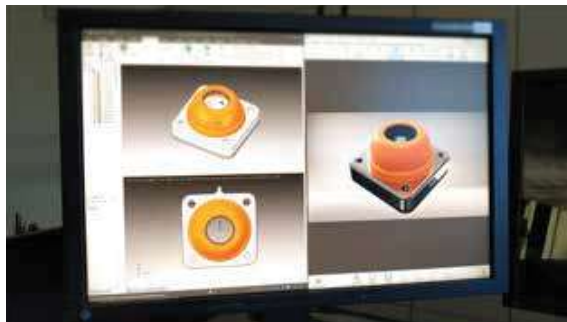

A sophisticated cad/cam system, very modern manufacturing facilities and an efficient storekeeping for finished goods enable us to match very high technology products and maximum reliability.

The flexibility, the high capacity of the productive resources and the warehouse dynamism enable us to guarantee an immediate availability of the products.



Tecom S.r.l.

Via A.M. Ampère, 43 - 42017 Novellara (RE) - Italy  
Tel.: (+39) 0522-651203 Fax.: (+39) 0522-756251  
Web: <http://www.tecomsrl.it> e-mail: [info@tecomsrl.it](mailto:info@tecomsrl.it)

## Conveyor components

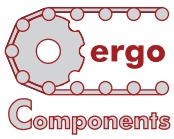

Conveyor components designed for bottling and food industry, support bases, heads, brackets, guide rail clamps produced in engineering resin and available with stainless steel or zinc plated bolts and nuts.



## Special products



Special products on request: chains and accessories, roller chains, cardanic chains, sprockets for chains, corner and straight tracks, etc.



## Self-aligning bearing supports



Self-aligning bearing supports made out of engineering resin, resistant to corrosion, ideal for food and pharmaceutical industry.



## Supporting and levelling components







Supporting elements made out of engineering resin, zinc plated steel and stainless steel, threaded bushings for round and square tubes, suitable to any kind of application.



## Conveyor components

Part.	Pag.	Part.	Pag.	Part.	Pag.	Part.	Pag.	Part.	Pag.	Part.	Pag.	Part.	Pag.
200	10	245	73	291	44	340	114	388	124	434	55	481	112
201	10	246	37	293	74	341	114	389	138	435	61	482	107
202	11	247	37	294	40	342	115	390	139	436	30	483	45
203	11	248	37	296	71	343	115	391	139	437	111	484	45
204	49	249	73	297	60	344	118	392	30	438	133	485	132
205	49	250	70	299	145	345	116	393	124	439	53	486	27
206	56	251	71	300	84	346	46	394	124	440	53	487	27
207	13	252	72	301	48	347	46	395	124	441	32	488	22
208	12	253	72	302	70	348	47	397	42	442	32	489	22
209	25	254	75	303	41	349	47	398	48	443	52	490	23
210	15	255	24	304	41	350	40	399	73	444	138	491	23
211	13	256	35	305	41	352	147	400	42	446	133	492	140
212	12	257	90	306	96	353	131	401	16	448	119	493	113
213	17	258	91	307	96	354	129	402	14	449	120	494	113
214	17	259	91	308	97	355	104	403	16	450	121	495	141
215	18	260	93	310	77	356	104	404	16	451	119	496	141
216	20	261	94	311	76	357	105	405	51	452	120	497	141
217	25	262	94	312	60	358	105	406	33	453	121	498	142
218	21	263	84	313	38	359	63	407	33	454	78	499	142
219	24	264	85	314	38	360	143	408	31	455	78	500	124
220	26	265	85	315	38	361	150	409	14	456	79	501	122
221	34	266	34	316	144	362	150	410	51	457	79	502	122
222	34	267	63	317	84	363	150	411	51	458	82	511	110
223	35	268	77	318	110	364	150	412	50	459	83	512	136
224	28	269	77	319	97	365	151	413	50	460	48	513	135
225	28	270	66	320	108	366	151	414	87	461	140	514	132
226	36	271	66	321	108	367	151	415	112	462	148	515	127
227	36	272	69	322	108	368	151	416	93	463	109	517	136
228	36	273	67	323	108	369	151	417	90	464	106	519	139
229	43	274	68	324	58	370	149	418	130	465	107	520	69
230	43	275	69	325	100	371	149	419	130	466	107	521	50
231	44	276	74	326	100	373	128	420	131	467	102	522	111
232	44	277	64	327	101	374	148	421	118	468	98	523	81
233	88	278	64	328	101	375	125	422	117	469	132	524	75
234	88	279	20	329	109	376	89	423	116	470	54	525	74
235	29	280	19	330	125	377	137	424	52	471	142	526	35
236	29	281	19	331	146	379	65	425	126	472	80	527	88
237	57	282	75	332	42	380	65	426	126	473	80	528	109
238	58	283	87	333	61	381	134	427	55	474	98	529	76
239	59	285	76	334	39	382	40	428	62	475	99	530	28
240	57	286	67	335	86	383	40	429	144	476	99	531	54
241	59	287	68	336	86	384	134	430	92	477	102	534	127
242	26	288	89	337	39	385	135	431	92	478	103	535	81
243	18	289	43	338	39	386	39	432	95	479	103	536	126
244	21	290	45	339	117	387	30	433	95	480	106		

### Bases

			
Part. 200 pag. 10	Part. 201 pag. 10	Part. 202 pag. 11	Part. 203 pag. 11

### Bearing heads

					
Part. 212 pag. 12	Part. 208 pag. 12	Part. 211 pag. 13	Part. 207 pag. 13	Part. 409 pag. 14	Part. 402 pag. 14



### Connecting joints

				
Part. 210 pag. 15	Part. 210 pag. 15	Part. 403 pag. 16	Part. 404 pag. 16	Part. 401 pag. 16

### Guide rail brackets

						
Part. 213 pag. 17	Part. 214 pag. 17	Part. 215 pag. 18	Part. 243 pag. 18	Part. 280 pag. 19	Part. 281 pag. 19	Part. 279 pag. 20
						
Part. 216 pag. 20	Part. 218 pag. 21	Part. 244 pag. 21	Part. 488 pag. 22	Part. 489 pag. 22	Part. 490 pag. 23	Part. 491 pag. 23
						
Part. 255 pag. 24	Part. 219 pag. 24	Part. 217 pag. 25	Part. 209 pag. 25	Part. 220 pag. 26	Part. 242 pag. 26	Part. 486 pag. 27
						
Part. 487 pag. 27	Part. 224 pag. 28	Part. 225 pag. 28	Part. 530 pag. 28	Part. 236 pag. 29	Part. 235 pag. 29	Part. 387 pag. 30
						
Part. 392 pag. 30	Part. 436 pag. 30	Part. 408 pag. 31	Part. 408 pag. 31	Part. 442 pag. 32	Part. 441 pag. 32	























### Tightening eyebolts

	Part. 406	pag. 33		Part. 407	pag. 33
---	-----------	---------	---	-----------	---------

### Heads for brackets

	Part. 222	pag. 34		Part. 221	pag. 34		Part. 266	pag. 34		Part. 223	pag. 35		Part. 256	pag. 35		Part. 526	pag. 35
---	-----------	---------	---	-----------	---------	---	-----------	---------	---	-----------	---------	---	-----------	---------	---	-----------	---------

### Knobs and handles

	Part. 226	pag. 36		Part. 227	pag. 36		Part. 228	pag. 36		Part. 246	pag. 37		Part. 247	pag. 37		Part. 248	pag. 37		Part. 313	pag. 38		Part. 314	pag. 38
	Part. 315	pag. 38		Part. 386	pag. 39		Part. 334	pag. 39		Part. 337	pag. 39		Part. 338	pag. 39		Part. 382	pag. 40		Part. 383	pag. 40		Part. 350	pag. 40
	Part. 294	pag. 40		Part. 303	pag. 41		Part. 304	pag. 41		Part. 305	pag. 41		Part. 397	pag. 42		Part. 400	pag. 42		Part. 332	pag. 42			

### Guide rail clamps

	Part. 230	pag. 43		Part. 289	pag. 43		Part. 229	pag. 43		Part. 231	pag. 44		Part. 232	pag. 44		Part. 291	pag. 44		Part. 483	pag. 45		Part. 484	pag. 45
	Part. 290	pag. 45		Part. 346	pag. 46		Part. 347	pag. 46		Part. 348	pag. 47		Part. 349	pag. 47		Part. 301	pag. 48		Part. 460	pag. 48		Part. 398	pag. 48
	Part. 204	pag. 49		Part. 205	pag. 49		Part. 412	pag. 50		Part. 413	pag. 50		Part. 521	pag. 50		Part. 410	pag. 51		Part. 411	pag. 51		Part. 405	pag. 51
	Part. 424	pag. 52		Part. 443	pag. 52		Part. 440	pag. 53		Part. 439	pag. 53		Part. 470	pag. 54		Part. 531	pag. 54		Part. 427	pag. 55		Part. 434	pag. 55

### Clamps

 Part. 206	 Part. 237	 Part. 240	 Part. 238	 Part. 324	 Part. 239
pag. 56	pag. 57	pag. 57	pag. 58	pag. 58	pag. 59
 Part. 241	 Part. 297	 Part. 312	 Part. 435	 Part. 333	
pag. 59	pag. 60	pag. 60	pag. 61	pag. 61	

### Shoes

 Part. 428	 Part. 267	 Part. 359
pag. 62	pag. 63	pag. 63

### Chain tensioners

 Part. 277	 Part. 278
pag. 64	pag. 64

### Return rollers

 Part. 379	 Part. 380	 Part. 270	 Part. 271	 Part. 273	 Part. 286	 Part. 287
pag. 65	pag. 65	pag. 66	pag. 66	pag. 67	pag. 67	pag. 68
 Part. 274	 Part. 275	 Part. 272	 Part. 520	 Part. 302	 Part. 250	 Part. 251
pag. 68	pag. 69	pag. 69	pag. 69	pag. 70	pag. 70	pag. 71
 Part. 296	 Part. 252	 Part. 253	 Part. 249	 Part. 245	 Part. 399	 Part. 293
pag. 71	pag. 72	pag. 72	pag. 73	pag. 73	pag. 73	pag. 74
 Part. 525	 Part. 276	 Part. 254	 Part. 524	 Part. 282		
pag. 74	pag. 74	pag. 75	pag. 75	pag. 75		



### Idler wheels

 Part. 311 pag. 76	 Part. 529 pag. 76	 Part. 285 pag. 76	 Part. 310 pag. 77	 Part. 268 pag. 77	 Part. 269 pag. 77	 Part. 455 pag. 78	 Part. 454 pag. 78
 Part. 457 pag. 79	 Part. 456 pag. 79	 Part. 472 pag. 80	 Part. 473 pag. 80	 Part. 535 pag. 81	 Part. 523 pag. 81	 Part. 458 pag. 82	 Part. 459 pag. 83

### Bearing supports

 Part. 300 pag. 84	 Part. 317 pag. 84	 Part. 263 pag. 84	 Part. 264 pag. 85	 Part. 265 pag. 85
--	--	--	--	--

### Bushings

 Part. 336 pag. 86	 Part. 335 pag. 86	 Part. 414 pag. 87	 Part. 283 pag. 87
---	---	---	---

### Hinges

 Part. 233 pag. 88	 Part. 234 pag. 88	 Part. 527 pag. 88
--	--	--





















































































### Split shaft collars

 Part. 288 pag. 89	 Part. 376 pag. 89
--	--

### Modular transfer plates

 Part. 257 pag. 90	 Part. 417 pag. 90	 Part. 258 pag. 91	 Part. 259 pag. 91	 Part. 430 pag. 92	 Part. 431 pag. 92
 Part. 260 pag. 93	 Part. 416 pag. 93	 Part. 261 pag. 94	 Part. 262 pag. 94	 Part. 432 pag. 95	 Part. 433 pag. 95

Product guides and accessories

 Part. 306 pag. 96	 Part. 307 pag. 96	 Part. 308 pag. 97	 Part. 319 pag. 97	 Part. 468 pag. 98	 Part. 474 pag. 98
 Part. 475 pag. 99	 Part. 476 pag. 99	 Part. 325 pag. 100	 Part. 326 pag. 100	 Part. 327 pag. 101	 Part. 328 pag. 101
 Part. 467 pag. 102	 Part. 477 pag. 102	 Part. 478 pag. 103	 Part. 479 pag. 103	 Part. 355 pag. 104	 Part. 356 pag. 104
 Part. 357 pag. 105	 Part. 358 pag. 105	 Part. 464 pag. 106	 Part. 480 pag. 106	 Part. 482 pag. 107	 Part. 466 pag. 107
 Part. 465 pag. 107	 Part. 320 pag. 108	 Part. 321 pag. 108	 Part. 322 pag. 108	 Part. 323 pag. 108	 Part. 329 pag. 109
 Part. 463 pag. 109	 Part. 528 pag. 109	 Part. 511 pag. 110	 Part. 318 pag. 110	 Part. 437 pag. 111	 Part. 522 pag. 111
 Part. 415 pag. 112	 Part. 481 pag. 112	 Part. 493 pag. 113	 Part. 494 pag. 113	 Part. 340 pag. 114	 Part. 341 pag. 114
 Part. 342 pag. 115	 Part. 343 pag. 115	 Part. 345 pag. 116	 Part. 423 pag. 116	 Part. 339 pag. 117	 Part. 422 pag. 117
 Part. 344 pag. 118	 Part. 421 pag. 118	 Part. 448 pag. 119	 Part. 451 pag. 119	 Part. 449 pag. 120	 Part. 452 pag. 120
 Part. 450 pag. 121	 Part. 453 pag. 121	 Part. 502 pag. 122	 Part. 501 pag. 122	 Part. 501 pag. 122	 Part. 501 pag. 123
 Part. 501 pag. 123	 Part. 388 pag. 124	 Part. 393 pag. 124	 Part. 394 pag. 124	 Part. 395 pag. 124	 Part. 500 pag. 124
 Part. 330 pag. 125	 Part. 375 pag. 125	 Part. 426 pag. 126	 Part. 425 pag. 126	 Part. 536 pag. 126	 Part. 515 pag. 127
 Part. 534 pag. 127	 Part. 373 pag. 128	 Part. 354 pag. 129	 Part. 418 pag. 130	 Part. 419 pag. 130	 Part. 420 pag. 131
 Part. 353 pag. 131	 Part. 469 pag. 132	 Part. 514 pag. 132	 Part. 485 pag. 132	 Part. 438 pag. 133	 Part. 370 pag. 149
 Part. 371 pag. 149					

### Chain guides and accessories

 Part. 446 pag. 133	<b>New</b>  Part. 381 pag. 134	 Part. 384 pag. 134	<b>New</b>  Part. 385 pag. 135	 Part. 513 pag. 135	 Part. 512 pag. 136
 Part. 517 pag. 136	 Part. 377 pag. 137	 Part. 444 pag. 138	 Part. 389 pag. 138	 Part. 519 pag. 139	 Part. 390 pag. 139
 Part. 391 pag. 139	 Part. 461 pag. 140	 Part. 492 pag. 140	 Part. 496 pag. 141	 Part. 495 pag. 141	 Part. 497 pag. 141
 Part. 471 pag. 142	 Part. 498 pag. 142	 Part. 499 pag. 142	 Part. 361 pag. 150	 Part. 362 pag. 150	 Part. 363 pag. 150
 Part. 364 pag. 150	<b>New</b>  Part. 365 pag. 151	<b>New</b>  Part. 366 pag. 151	 Part. 367 pag. 151	 Part. 368 pag. 151	 Part. 369 pag. 151

### Accessories for the cross adjustment of the side guides

 Part. 429 pag. 144	 Part. 316 pag. 144	 Part. 299 pag. 145	 Part. 331 pag. 146
 Part. 352 pag. 147	 Part. 462 pag. 148	 Part. 374 pag. 148	

### Process control

 Part. 360 pag. 143
--

# Return rollers

Example of application

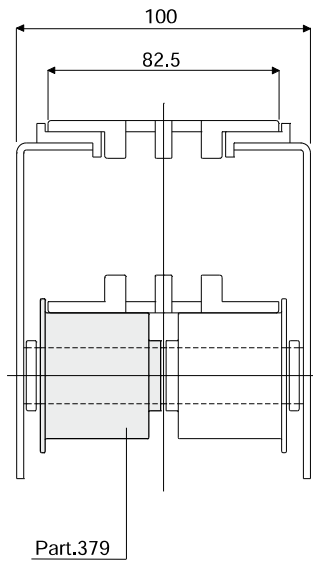

## Roller for chain return (with flange)

Part. **379**

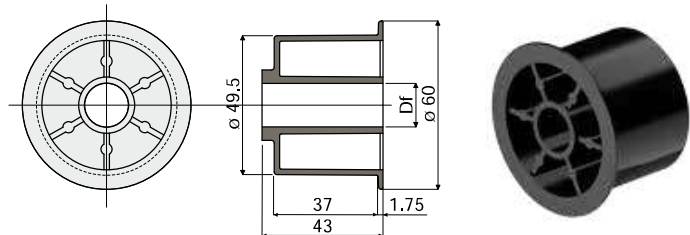

Df Bore for pin of (mm)	Code
15	379 / 84069
20	379 / 84070

**MATERIALS:** Roller made of reinforced polyamide, black colour.

**FEATURES:** To be assembled in the chain return.

**BOX QUANTITY:** 96 pieces.

**ON REQUEST:**

- Rollers: with special bores, in different colours.
- Box quantity: According to your request.

Example of application

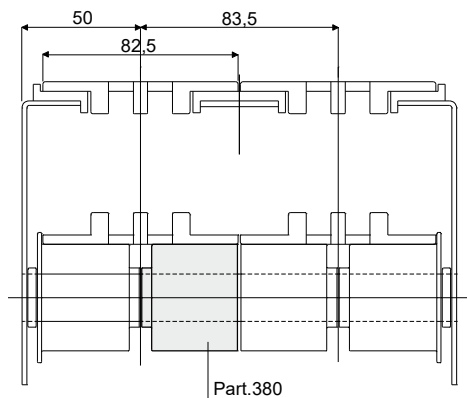

## Roller for chain return (without flange)

Part. **380**

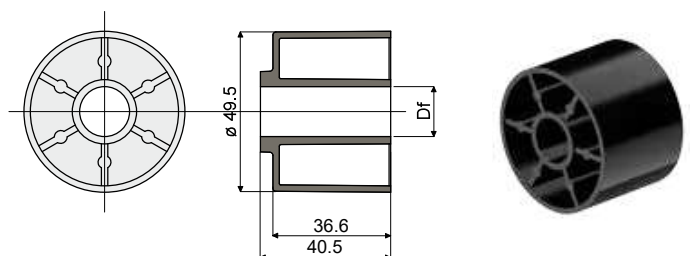

Df Bore for pin of (mm)	Code
15	380 / 84071
20	380 / 84072

**MATERIALS:** Roller made of reinforced polyamide, black colour.

**FEATURES:** To be assembled in the chain return.

**BOX QUANTITY:** 96 pieces.

**ON REQUEST:**

- Rollers: With special bores, in different colours.
- Box quantity: According to your request.

# Return rollers

## Part. 270 Roller for chain return (with flange)

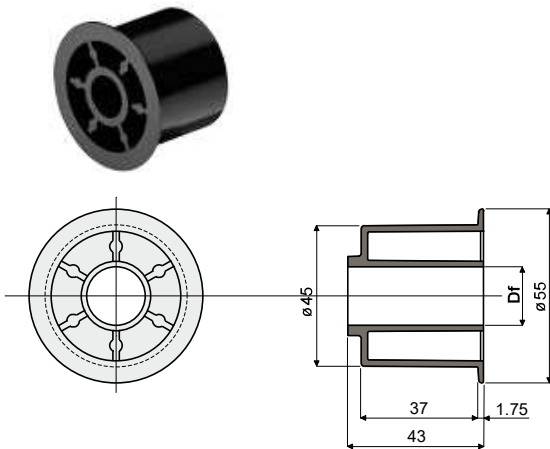

Df Bore for pin of (mm)	Code
15	270 / 82042
20	270 / 82043

**MATERIALS:** Roller made of polyamide black colour.

**FEATURES:** To be assembled in the chain return.

**BOX QUANTITY:** 96 pieces.

**ON REQUEST:**

- Rollers: Special bores, other colours.
- Box quantity: According to your request.

### Example of application

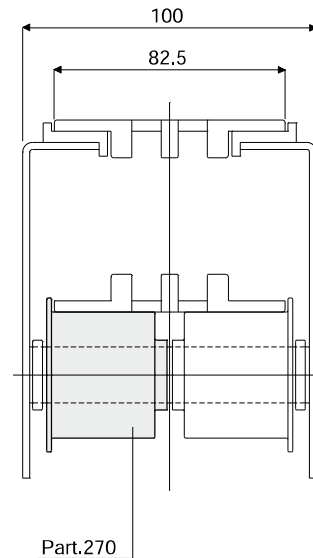

## Part. 271 Roller for chain return (without flange)

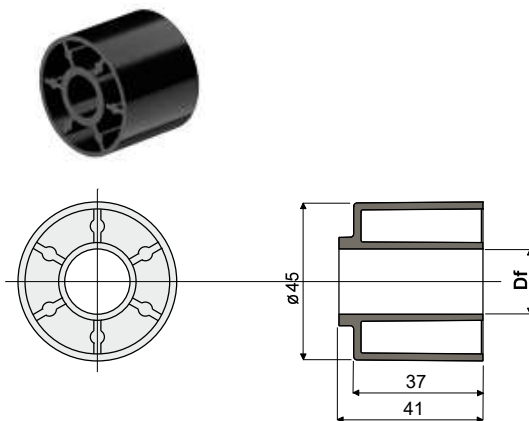

Df Bore for pin of (mm)	Code
15	271 / 82044
20	271 / 82045

**MATERIALS:** Roller made of polyamide black colour.

**FEATURES:** To be assembled in the chain return.

**BOX QUANTITY:** 96 pieces.

**ON REQUEST:**

- Rollers: Special bores, other colours.
- Box quantity: According to your request.

### Example of application

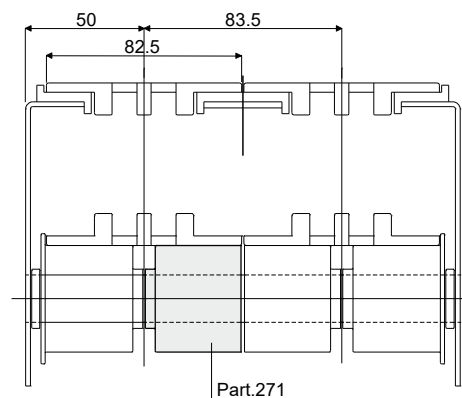

# Return rollers

Example of application

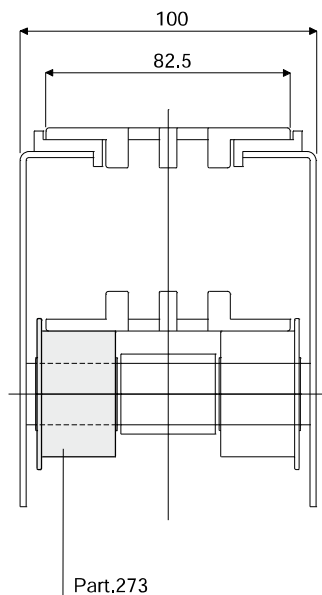

## Roller for chain return (with flange) Part. 273

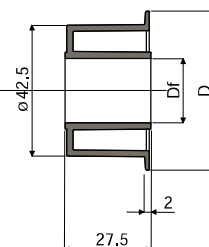
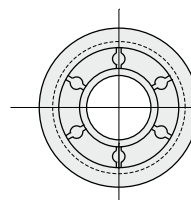

Df Bore for pin of (mm)	D = 51	D = 55
	Code	Code
12	273 / 82048	273 / 85337
16	273 / 82049	273 / 85338
18	273 / 82050	273 / 85339
20	273 / 82051	273 / 85340

**MATERIALS:** Roller made of polyamide black colour.

**FEATURES:** To be assembled in the chain return.

**BOX QUANTITY:** 96 pieces.

**ON REQUEST:**

- Rollers: Special bores, other colours.
- Box quantity: According to your request.

Example of application

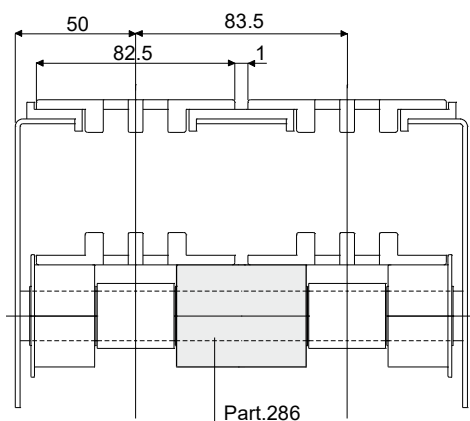

## Double roller for chain return (without central flange) Part. 286

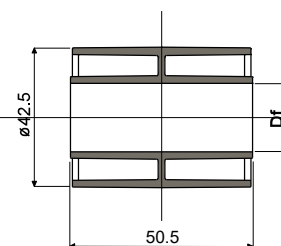
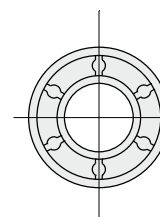

Df Bore for pin of (mm)	Code
12	286 / 82532
16	286 / 82533
18	286 / 82534
20	286 / 82535

**MATERIALS:** Roller made of polyamide black colour.

**FEATURES:** To be assembled in the chain return.

**BOX QUANTITY:** 96 pieces.

**ON REQUEST:**

- Rollers: Special bores, other colours.
- Box quantity: According to your request.

# Return rollers

## Part. 287 Double roller for chain return (with central flange)

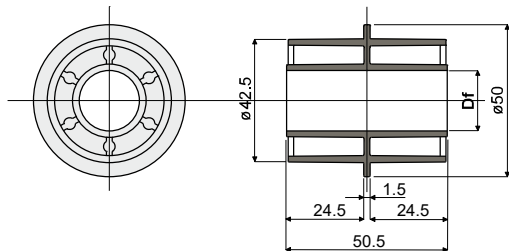

Df Bore for pin of (mm)	Code
12	287 / 82536
16	287 / 82537
18	287 / 82538
20	287 / 82539

**MATERIALS:** Roller made of polyamide black colour.

**FEATURES:** To be assembled in the chain return.

**BOX QUANTITY:** 96 pieces.

**ON REQUEST:**

- Rollers: Special bores, other colours.
- Box quantity: According to your request.

### Example of application

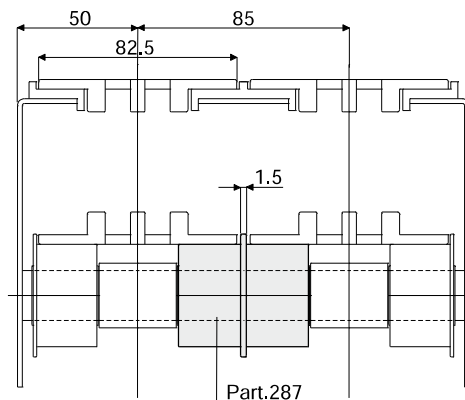

## Part. 274 Double roller for chain return (with central flange)

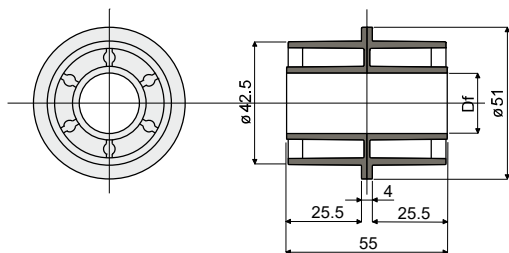

Df Bore for pin of (mm)	Code
12	274 / 82052
16	274 / 82053
18	274 / 82054
20	274 / 82055

**MATERIALS:** Roller made of polyamide black colour.

**FEATURES:** To be assembled in the chain return.

**BOX QUANTITY:** 96 pieces.

**ON REQUEST:**

- Rollers: Special bores, other colours.
- Box quantity: According to your request.

### Example of application

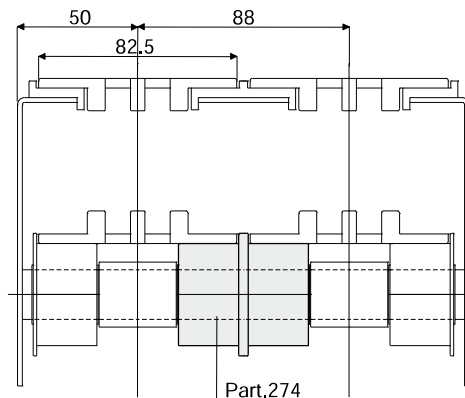

# Return rollers

Example of application

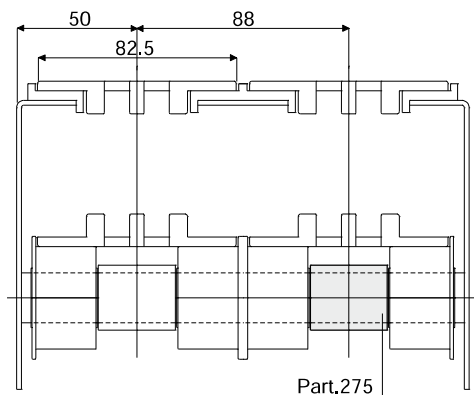

Example of application

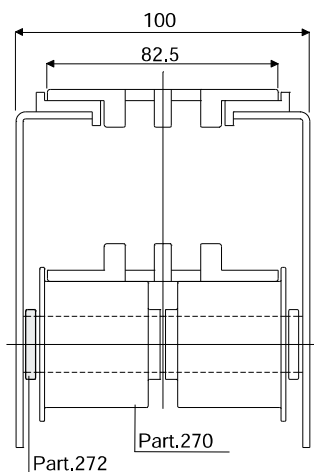

Example of application

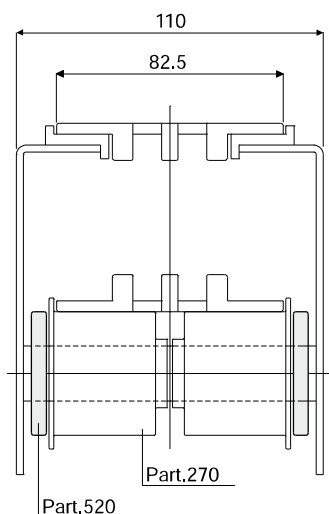

## Spacer for rollers for chain return

Part. **275**



Df Bore for pin of (mm)	Code
12	275 / 82056
16	275 / 82057
18	275 / 82058
20	275 / 82059

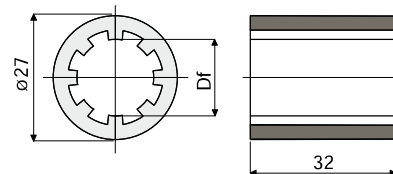

**MATERIALS:** Spacer made of polyamide black colour.

**FEATURES:** To be assembled in the chain return.

**BOX QUANTITY:** 96 pieces.

**ON REQUEST:**

- Spacers: Special bores, other colours,
- Box quantity: According to your request.

## Spacer for rollers for chain return

Part. **272**



Df Bore for pin of (mm)	S	Code
15	3,5	272 / 82046
16	3,5	272 / 83331
	5	272 / 86091
20	3,5	272 / 82047
	5	272 / 85186

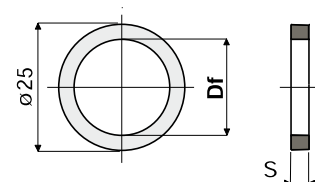

**MATERIALS:** Spacer made of polyamide black colour.

**FEATURES:** To be assembled in the chain return.

**BOX QUANTITY:** 96 pieces.

**ON REQUEST:**

- Spacers: Special bores, other colours.
- Box quantity: According to your request.

## Spacer for rollers for chain return

Part. **520**



Df Bore for pin of (mm)	Code
20	520 / 87264

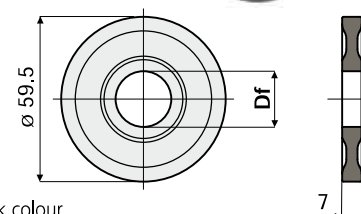

**MATERIALS:** Spacer made of polypropylene black colour.

**FEATURES:** To be assembled in the chain return.

**BOX QUANTITY:** 96 pieces.

**ON REQUEST:**

- Spacers: Special bores, other colours.
- Box quantity: According to your request.



# Return rollers

## Part. 302 Spacer for chain profiles

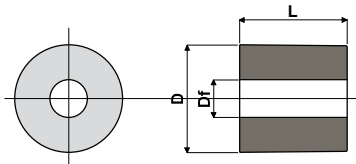

Df Bore diameter (mm)	D (mm)	L (mm)	Code
7	20	20	302 / 82797
7	20	27,5	302 / 82873

**MATERIALS:** Spacer made of reinforced polyamide black colour.

**FEATURES:** To be used as fixing spacer for chain profiles.

**BOX QUANTITY:** 96 pieces.

**ON REQUEST:**

- Spacers: With special bores and sizes.
- Box quantity: According to your request.

## Part. 250 Roller for chain return (with flange)

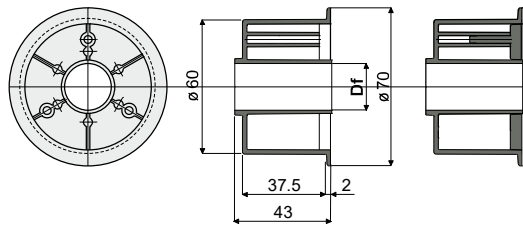

Without cap closure

With cap closure

Df Bore for pin of (mm)	Without cap closure	With cap closure
	Code	Code
15	250 / 82201	250 / 82219
16	250 / 82202	250 / 82220
18	250 / 82203	250 / 82221
20	250 / 82204	250 / 82222

**MATERIALS:** Roller made out of polyamide black colour; cap made out of polyamide grey colour.

**FEATURES:** To be assembled in the chain return.

**BOX QUANTITY:** 96 pieces.

**ON REQUEST:**

- Rollers: Special bores, other colours.
- Box quantity: According to your request.

### Example of application

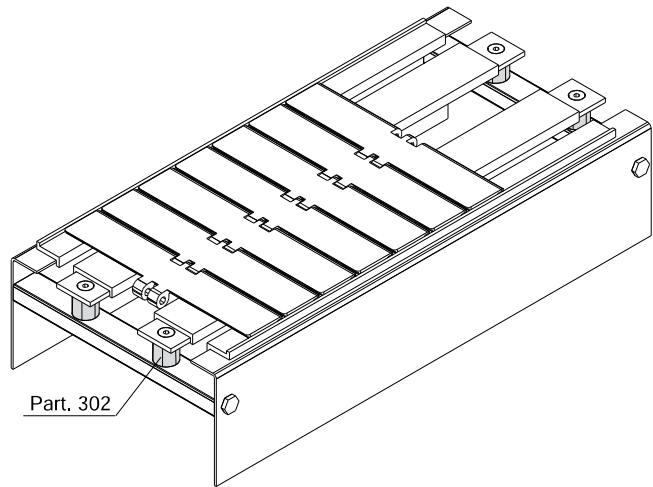

### Example of application

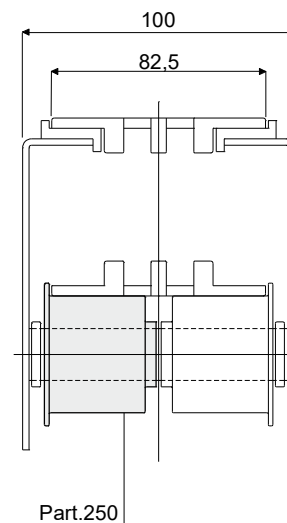

# Return rollers

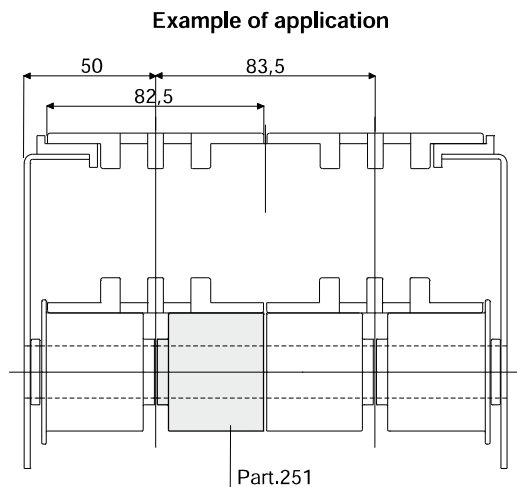

## Roller for chain return (without flange) Part. 251

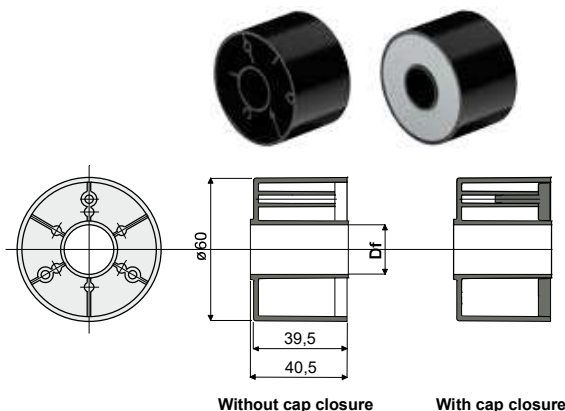

Df Bore for pin of (mm)	Without cap closure	With cap closure
	Code	Code
15	251 / 82205	251 / 82223
16	251 / 82206	251 / 82224
18	251 / 82207	251 / 82225
20	251 / 82208	251 / 82226

**MATERIALS:** Roller made out of polyamide black colour; cap made out of polyamide grey colour.  
**FEATURES:** To be assembled in the chain return.

**BOX QUANTITY:** 96 pieces.

**ON REQUEST:**

- Rollers: Special bores, other colours.
- Box quantity: According to your request.

## Example of application

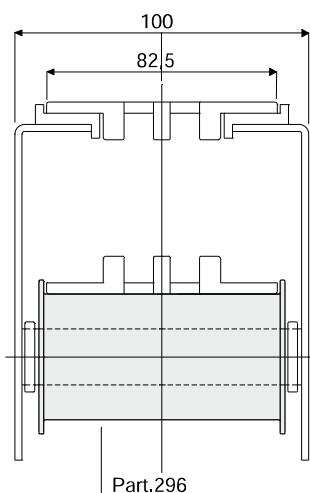

## Roller for chain return (with double flange) Part. 296

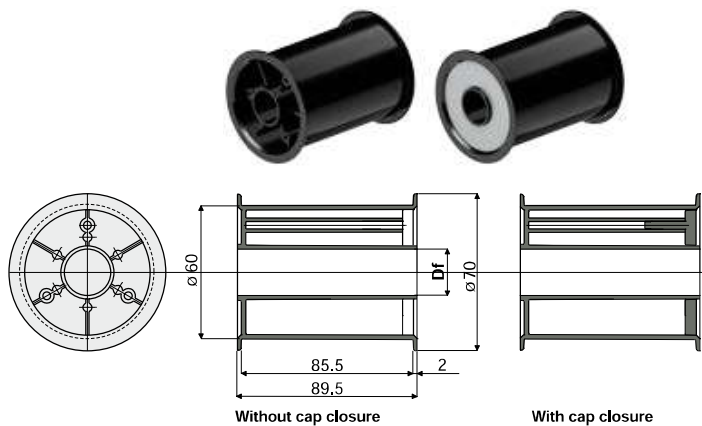

Df Bore for pin of (mm)	Without cap closure	With cap closure
	Code	Code
12	296 / 82611	296 / 82612
14	296 / 82613	296 / 82614
15	296 / 82615	296 / 82616
16	296 / 82617	296 / 82618
18	296 / 82619	296 / 82620
20	296 / 82621	296 / 82622

**MATERIALS:** Roller made out of polyamide black colour; cap made out of polyamide grey colour.

**FEATURES:** To be assembled in the chain return.

**BOX QUANTITY:** 48 pieces.

**ON REQUEST:**

- Rollers: Special bores, other colours.
- Box quantity: According to your request.

# Return rollers

## Part. 252 Roller for chain return (with flange)

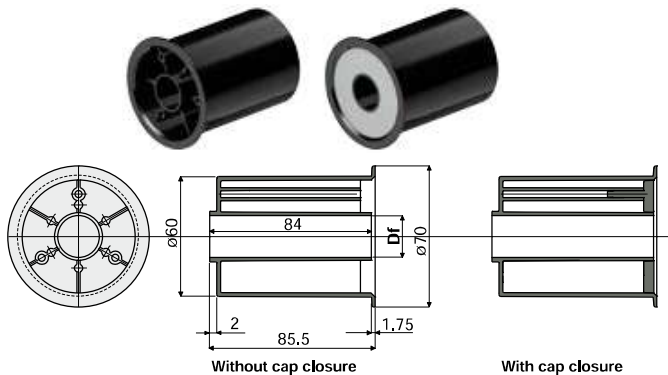

Df Bore for pin of (mm)	Without cap closure		With cap closure	
	Code		Code	
12	252 / 82624		252 / 82625	
14	252 / 82258		252 / 82259	
15	252 / 82227		252 / 82231	
16	252 / 82228		252 / 82232	
18	252 / 82229		252 / 82233	
20	252 / 82230		252 / 82234	
25	252 / 83307		-	
30	252 / 83309		-	

**MATERIALS:** Roller made out of polyamide black colour; cap made out of polyamide grey colour.

**FEATURES:** To be assembled in the chain return.

**BOX QUANTITY:** 48 pieces.

**ON REQUEST:**

- Rollers: Special bores, other colours.
- Box quantity: According to your request.

### Example of application

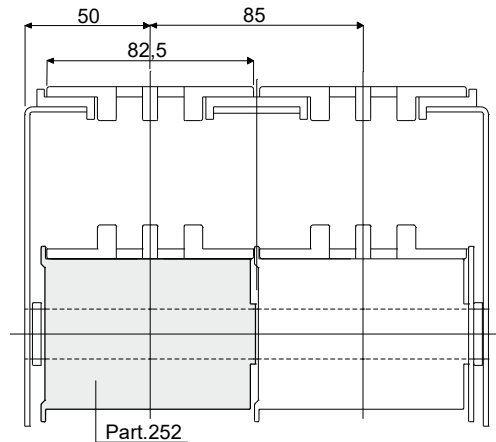

## Part. 253 Roller for chain return (without flange)

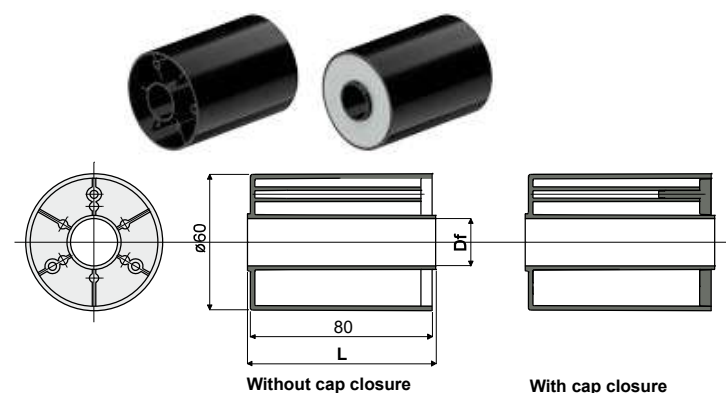

Df Bore for pin of (mm)	Without cap closure		With cap closure	
	L = 82 mm Code	L = 84 mm Code	L = 82 mm Code	L = 84 mm Code
12	253 / 82626	253 / 82627	253 / 82628	253 / 82629
14	253 / 82260	253 / 82261	253 / 82262	253 / 82263
15	253 / 82235	253 / 82239	253 / 82243	253 / 82247
16	253 / 82236	253 / 82240	253 / 82244	253 / 82248
18	253 / 82237	253 / 82241	253 / 82245	253 / 82249
20	253 / 82238	253 / 82242	253 / 82246	253 / 82250
25	-	253 / 83313	-	-
30	-	253 / 83314	-	-

**MATERIALS:** Roller made out of polyamide black colour; cap made out of polyamide grey colour.

**FEATURES:** To be assembled in the chain return.

**BOX QUANTITY:** 48 pieces.

**ON REQUEST:**

- Rollers: Special bores, other colours.
- Box quantity: According to your request.

### Example of application

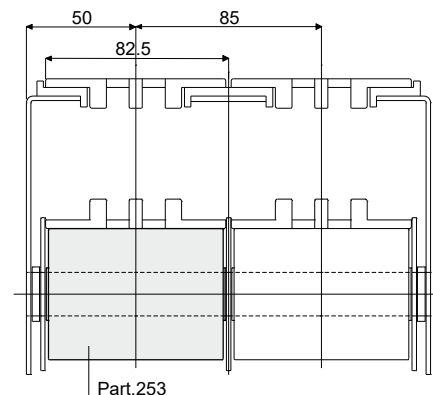

# Return rollers

Example of application

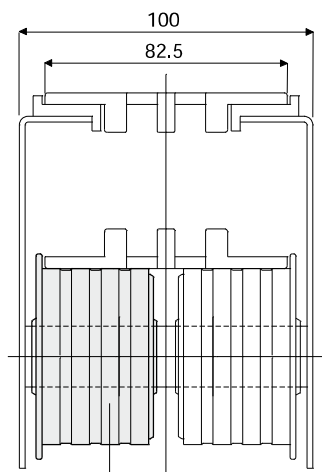

Part.249

Example of application

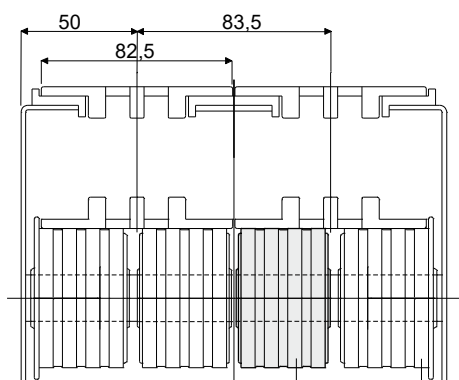

Part.245

Part.249

Example of application

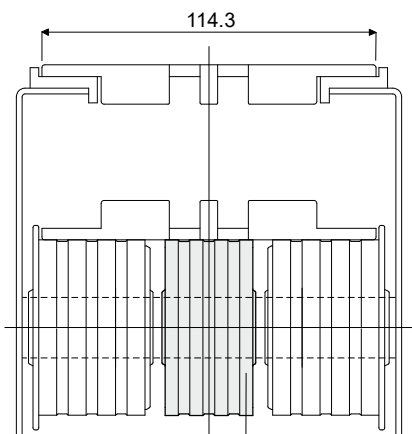

Part.399

## Roller with rubber for chain return (with flange)

Part. 249

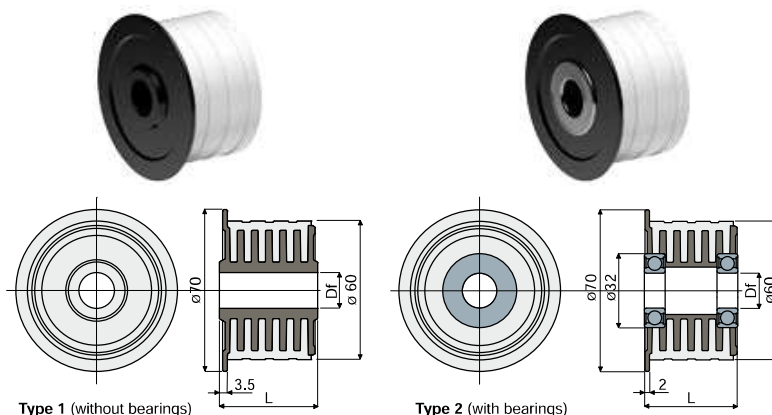

Df Bore for pin of (mm)	L (mm)	Type 1 (without bearings) Code
15	22	249 / 85346
15	43	249 / 82021
16	22	249 / 85347
16	43	249 / 82022
18	22	249 / 85348
18	43	249 / 82023
20	22	249 / 85349
20	43	249 / 82024

Df Bore for pin of (mm)	L (mm)	Type 2 (with bearings) Code	Type of bearings
15	40.5	249 / 83642	6002-ZZ

**MATERIALS:** Internal part is made of polyamide black colour; external rubber is made of thermoplastic rubber grey colour 65 Shore; bearing made of chrome steel.

**FEATURES:** This roller is completely closed, total lack of internal cavities to obtain the maximum level of cleanliness and noiselessness during working operations.

**BOX QUANTITY:** 48 pieces.

**ON REQUEST:**

- Rollers: Special bores, other colours.
- Box quantity: According to your request.

## Roller with rubber for chain return (without flange)

Part. 245

Df Bore for pin of (mm)	Code
12	245 / 84180
15	245 / 82017
16	245 / 82018
18	245 / 82019
20	245 / 82020

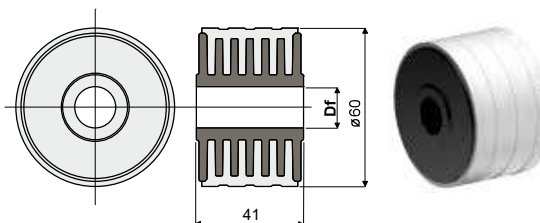

**MATERIALS:** Internal part is made of polyamide black colour; external rubber is made of thermoplastic rubber grey colour 65 Shore.

**FEATURES:** This roller is completely closed, total lack of internal cavities to obtain the maximum level of cleanliness and noiselessness during working operations.

**BOX QUANTITY:** 48 pieces.

**ON REQUEST:**

- Rollers: Special bores, other colours.
- Box quantity: According to your request.

## Roller with rubber for chain return (without flange)

Part. 399

Df Bore for pin of (mm)	Code
12	399 / 84304
15	399 / 84305
16	399 / 84306
18	399 / 84307
20	399 / 84308

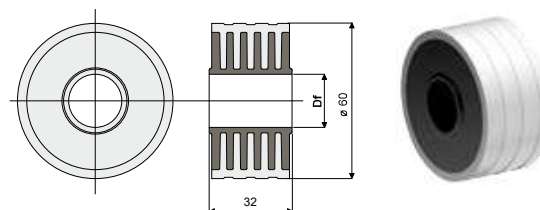

**MATERIALS:** Internal part is made of polyamide black colour; external rubber is made of thermoplastic rubber grey colour 65 Shore.

**FEATURES:** This roller is completely closed, total lack of internal cavities to obtain the maximum level of cleanliness and noiselessness during working operations.

**BOX QUANTITY:** 48 pieces.

**ON REQUEST:**

- Rollers: Special bores, other colours.
- Box quantity: According to your request.

# Return rollers

## Part. 293

### Roller with rubber for chain return (without flange)

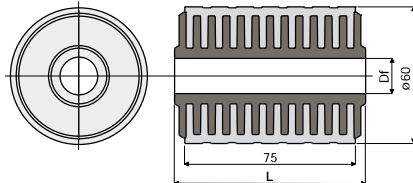

Df Bore for pin of (mm)	L = 82 mm	L = 84 mm
	Code	Code
12	293 / 82789	293 / 82833
15	293 / 82580	293 / 82581
16	293 / 82582	293 / 82583
18	293 / 82584	293 / 82585
20	293 / 82586	293 / 82587
25	293 / 87465	293 / 87466
30	293 / 87467	293 / 87468

**MATERIALS:** Internal part is made of polyamide black colour; external rubber is made of thermoplastic rubber grey colour 65 Shore.  
**FEATURES:** This roller is completely closed, total lack of internal cavities to obtain the maximum level of cleanliness and noiselessness during working operations.

**BOX QUANTITY:** 48 pieces.

**ON REQUEST:**

- Rollers: Special bores, other colours.
- Box quantity: According to your request.

## Part. 525

### Roller with rubber for chain return (with flange)

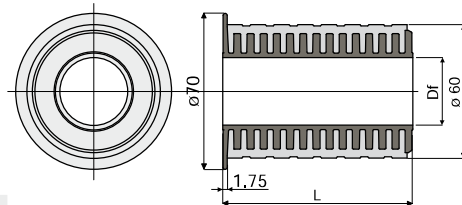

Df Bore for pin of (mm)	L (mm)	Code
30	85,5	525 / 87379

**MATERIALS:** Internal part is made of polyamide black colour; external rubber is made of thermoplastic rubber grey colour 65 Shore.

**FEATURES:** This roller is completely closed, total lack of internal cavities to obtain the maximum level of cleanliness and noiselessness during working operations.

**BOX QUANTITY:** 48 pieces.

**ON REQUEST:**

- Rollers: Special bores, other colours.
- Box quantity: According to your request.

## Part. 276

### Roller with rubber for chain return (without flange)

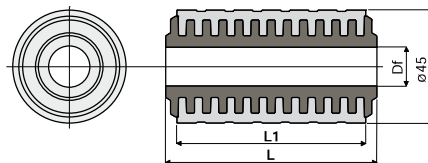

Df Bore for pin of (mm)	L = 41 mm	L = 82 mm	L = 84 mm
	L1 = 36 mm	L1 = 75 mm	L1 = 75 mm
	Code	Code	Code
12	276 / 85466	276 / 82853	276 / 82855
15	276 / 85462	276 / 82060	276 / 82061
16	276 / 85463	276 / 82062	276 / 82063
18	276 / 85464	276 / 82064	276 / 82065
20	276 / 85465	276 / 82066	276 / 82067

**MATERIALS:** Internal part is made of polyamide black colour; external rubber is made of thermoplastic rubber grey colour 65 Shore.  
**FEATURES:** This roller is completely closed, total lack of internal cavities to obtain the maximum level of cleanliness and noiselessness during working operations.

**BOX QUANTITY:** 48 pieces.

**ON REQUEST:**

- Rollers: Special bores, other colours.
- Box quantity: According to your request.

### Example of application

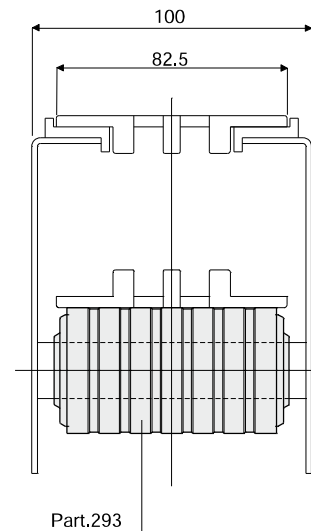

Part.293

### Example of application

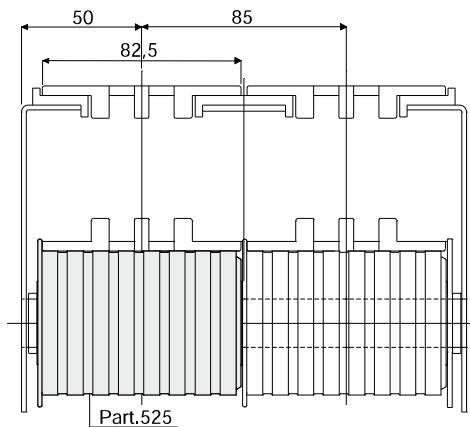

Part.525

### Example of application

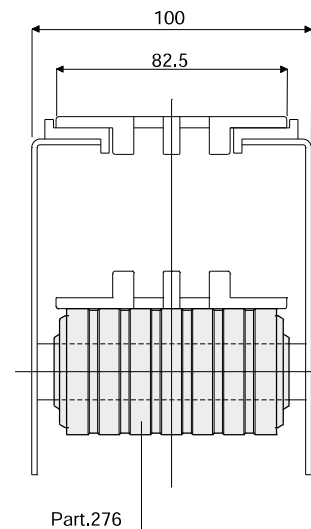

Part.276

# Return rollers

Example of application

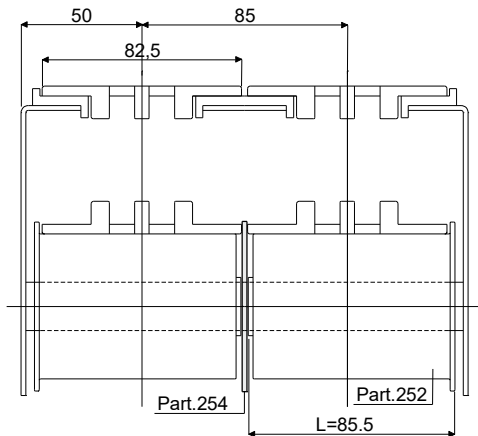

Example of application

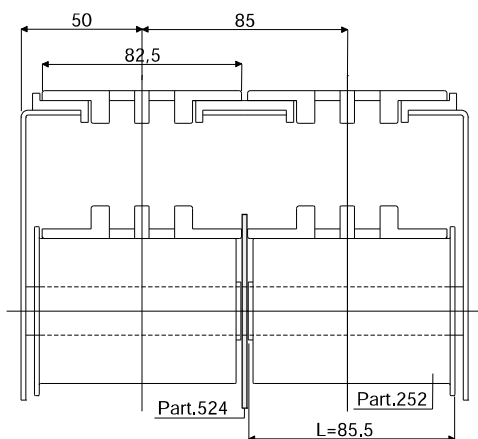

Example of application

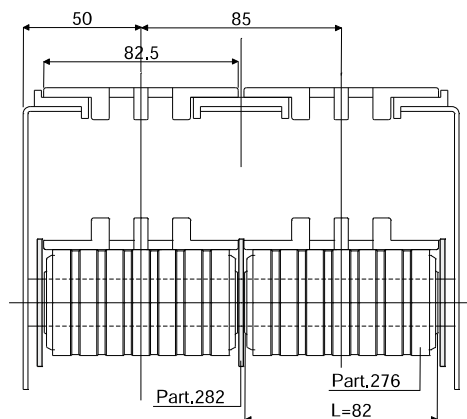

## Flange for chain guide

(for roller Part. 251, 252, 253, 245, 293, 250, 249, 399, 525)

Part. **254**

Df	Bore for pin of (mm)	Code
12	254 / 82630	
14	254 / 82264	
15	254 / 82251	
16	254 / 82252	
18	254 / 82253	
20	254 / 82254	

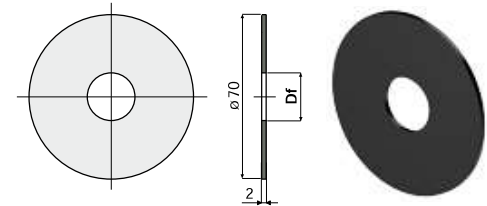

**MATERIALS:** Flange is made of polypropylene black colour.

**FEATURES:** To be assembled to our roller for chain return Part.251, 252, 253, 245, 293, 250, 249, 399, 525.

**BOX QUANTITY:** 96 pieces.

**ON REQUEST:**

- **Flanges:** Special bores, other colours.
- **Box quantity:** According to your request.

## Flange for chain guide

(for roller Part. 251, 252, 253, 245, 293, 250, 249, 399, 525)

Part. **524**

Df	Bore for pin of (mm)	Code
12	524 / 87385	
16	524 / 87388	
20	524 / 87390	

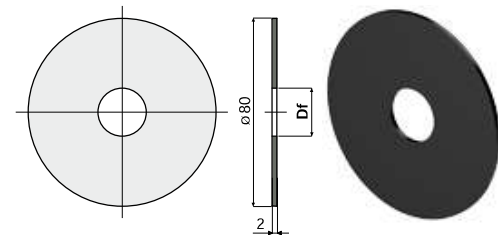

**MATERIALS:** Flange is made of polypropylene black colour.

**FEATURES:** To be assembled to our roller for chain return Part.251, 252, 253, 245, 293, 250, 249, 399, 525.

**BOX QUANTITY:** 96 pieces.

**ON REQUEST:**

- **Flanges:** Special bores, other colours.
- **Box quantity:** According to your request.

## Flange for chain guide

(for Part. 276, 271, 270)

Part. **282**

Df	Bore for pin of (mm)	Code
15	282 / 82154	
16	282 / 82155	
18	282 / 82156	
20	282 / 82157	

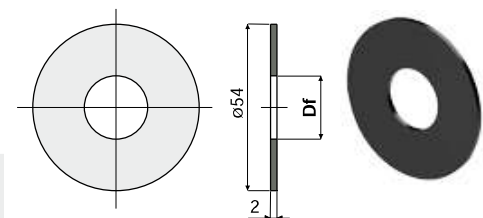

**MATERIALS:** Flange is made of polypropylene black colour.

**FEATURES:** To be assembled to our roller for chain return Part.276, 271, 270.

**BOX QUANTITY:** 96 pieces.

**ON REQUEST:**

- **Flanges:** Special bores, other colours.
- **Box quantity:** According to your request.

# Idler wheels

## Part. 311

### Split idler wheel 21 teeth (for chains series 812-815-820-831)

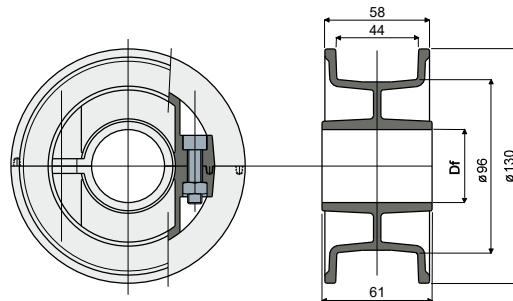

Df Bore for pin of (mm)	Code
25	311 / 82841
30	311 / 82842
35	311 / 82843
40	311 / 82844

**MATERIALS:** Wheel made of polyamide black colour; bolts and nuts made of stainless steel AISI 304.

**FEATURES:** Supplied assembled. To be used for chain return in the series 812, 815, 820, 831.

**BOX QUANTITY:** 12 pieces.

**ON REQUEST:**

- Wheels: With special bores, other colours.
- Box quantity: According to your request.

## Part. 529

### Split idler wheel 23 teeth (for chains series 812-815-820-831)

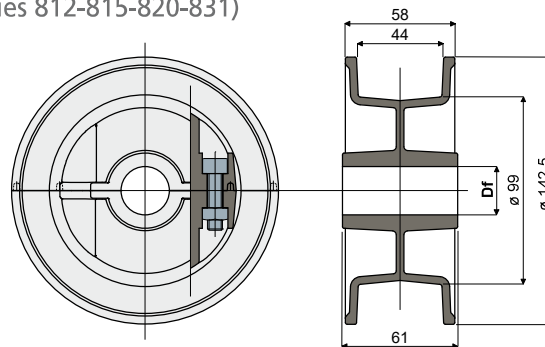

Df Bore for pin of (mm)	Code
25	529 / 87589
30	529 / 87590
35	529 / 87591
40	529 / 87592

**MATERIALS:** Wheel made of polyamide black colour; bolts and nuts made of stainless steel AISI 304.

**FEATURES:** Supplied assembled. To be used for chain return in the series 812, 815, 820, 831.

**BOX QUANTITY:** 12 pieces.

**ON REQUEST:**

- Wheels: With special bores, other colours.
- Box quantity: According to your request.

## Part. 285

### Split idler wheel 25 teeth (for chains series 812-815-820-831)

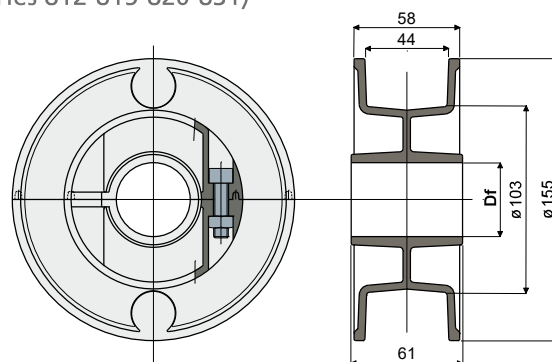

Df Bore for pin of (mm)	Code
25	285 / 82526
30	285 / 82528
35	285 / 82529
40	285 / 82530

**MATERIALS:** Wheel made of polyamide black colour; bolt and nuts made of stainless steel AISI 304.

**FEATURES:** Supplied assembled. To be used for chains Series 812, 815, 820, 831.

**BOX QUANTITY:** 12 pieces.

**ON REQUEST:**

- Wheels: With special bores, other colours, with customer brand.
- Box quantity: According to your request.

# Idler wheels

## Split idler wheel 10 teeth

(for chains series 879 TAB, 880 TAB and 881 TAB)

Part. **310**

Df Bore for pin of (mm)	Code
20	310 / 82827
25	310 / 82828
30	310 / 82829
35	310 / 82830
40	310 / 82831

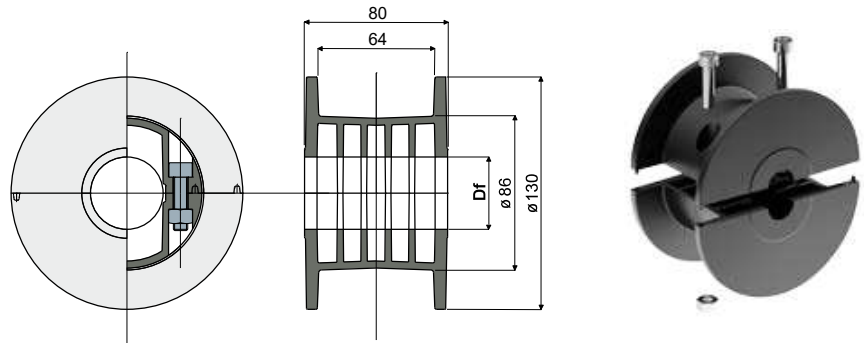

**MATERIALS:** Wheel made of polyamide black colour; bolts and nuts made of stainless steel AISI 304.

**FEATURES:** Supplied assembled. To be used with chains Part.710, 711, 713.

**BOX QUANTITY:** 12 pieces.

**ON REQUEST:**

- **Wheels:** With special bores, other colours.
- **Box quantity:** According to your request.

## Idler wheel for chain return

Part. **268**

Df Bore for pin of (mm)	Code
20	268 / 82040

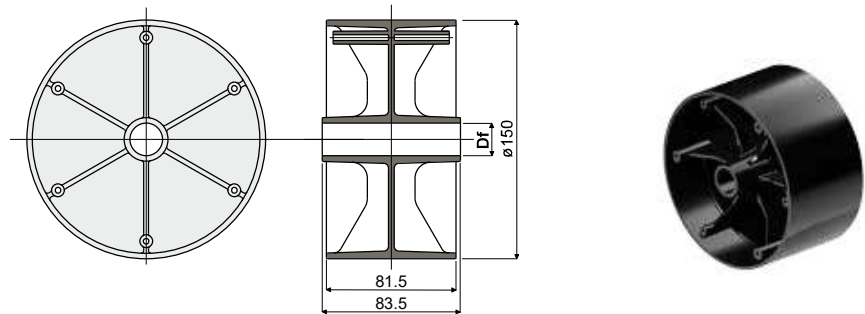

**MATERIALS:** Wheel in polyamide black colour.

**FEATURES:** To be assembled in the chain return near to the sprocket.

**BOX QUANTITY:** 12 pieces.

**ON REQUEST:**

- **Wheels:** Other bore sizes, materials and colours.
- **Box quantity:** According to your request.

## Flange for chain guide

(for idler wheel Part. 268)

Part. **269**

Df Bore for pin of (mm)	Code
20	269 / 82041

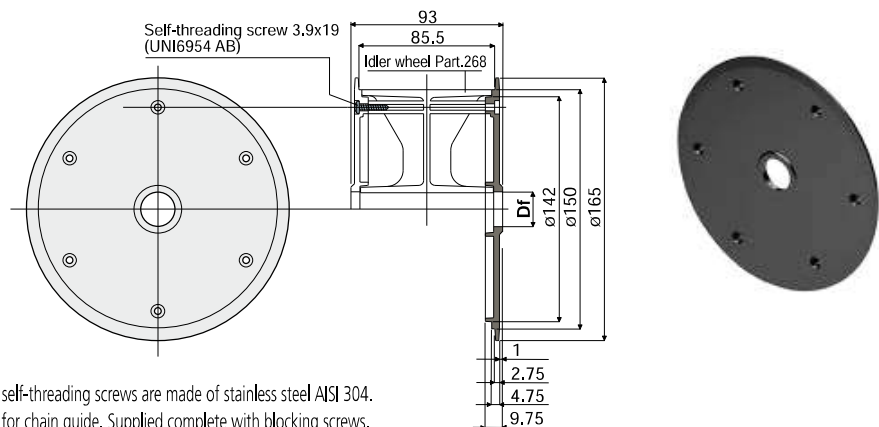

**MATERIALS:** Flange is made of polyamide black colour; self-threading screws are made of stainless steel AISI 304.

**FEATURES:** To be assembled to our idler wheel Part.268 for chain guide. Supplied complete with blocking screws.

**BOX QUANTITY:** 24 pieces.

**ON REQUEST:**

- **Flanges:** Other bore sizes, materials and colours.
- **Box quantity:** According to your request.



# Idler wheels

## Part. 455 Split idler wheel 10 teeth (for chains series 879, 879 TAB, 880, 880 TAB)

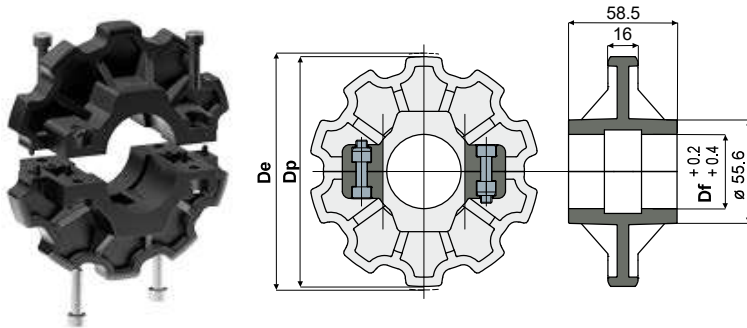

Df (mm)	Dp (mm)	De (mm)	Code
25	123,3	122,5	455 / 85420
30	123,3	122,5	455 / 85421
35	123,3	122,5	455 / 85422
40	123,3	122,5	455 / 85423

**MATERIALS:** Wheel made of polyamide black colour; screws made of stainless steel AISI 304, nuts in nickel plated brass.

**FEATURES:** To be used with chains Part.710, 711, 713.

**BOX QUANTITY:** 8 pieces.

**ON REQUEST:**

- Wheels: In other materials.
- Box quantity: According to your request.

## Part. 454 Split sprocket 10 teeth (for chains series 879, 879 TAB, 880, 880 TAB)

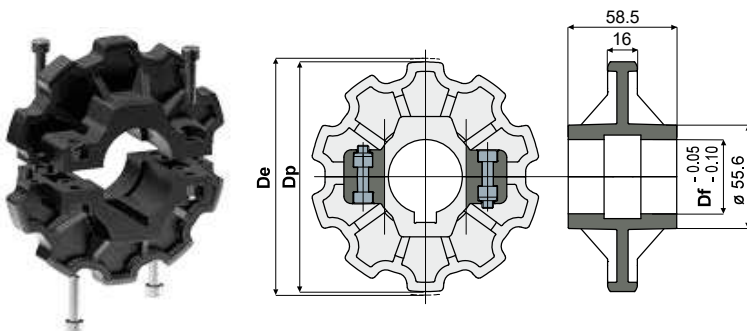

Df (mm)	Dp (mm)	De (mm)	Code
25	123,3	122,5	454 / 85416
30	123,3	122,5	454 / 85417
35	123,3	122,5	454 / 85418
40	123,3	122,5	454 / 85419

**MATERIALS:** Wheel made of reinforced polyamide black colour; screws made of stainless steel AISI 304, nuts in nickel plated brass.

**FEATURES:** Dimensions of the keyway UNI 6604-69 - DIN 6885/1.

To be used with chains Part.710, 711, 713.

**BOX QUANTITY:** 8 pieces.

**ON REQUEST:**

- Wheels: In other materials.
- Box quantity: According to your request.

### Example of application

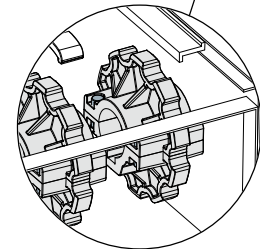
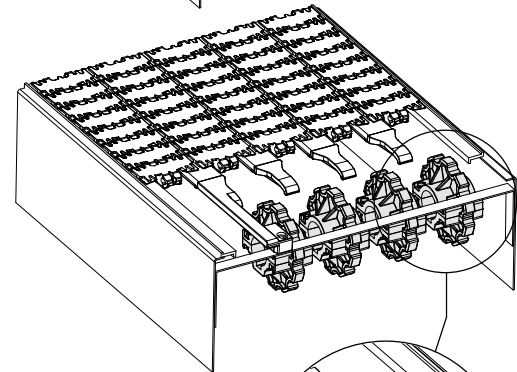
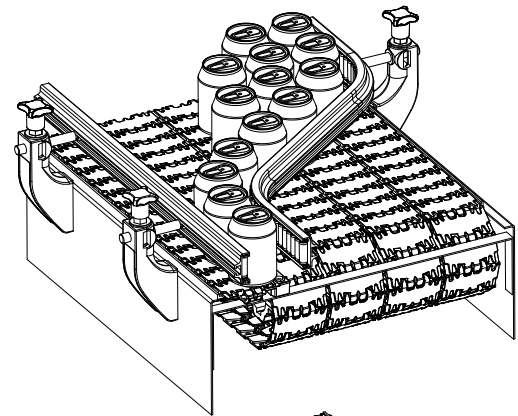

# Idler wheels

Example of application

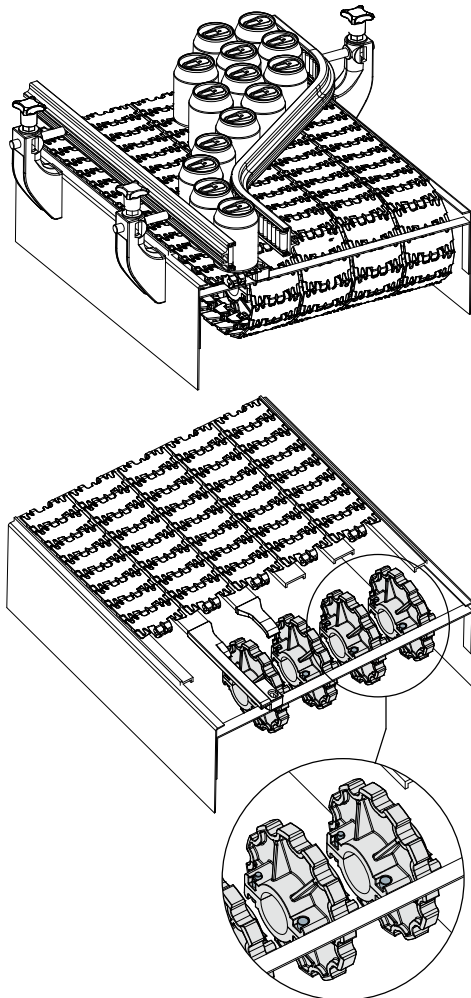

## Split idler wheel 12 teeth

(for chains series 879, 879 TAB, 880, 880 TAB)

Part. **457**

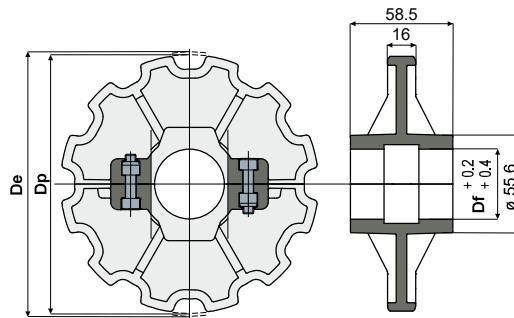

Df (mm)	Dp (mm)	De (mm)	Code
25	147,2	147,4	457 / 85428
30	147,2	147,4	457 / 85429
35	147,2	147,4	457 / 85430
40	147,2	147,4	457 / 85431

**MATERIALS:** Wheel made of polyamide black colour; screws made of stainless steel AISI 304, nuts in nickel plated brass.

**FEATURES:** To be used with chains Part.710, 711, 713.

**BOX QUANTITY:** 8 pieces.

**ON REQUEST:**

- Wheels: In other materials.
- Box quantity: According to your request.

## Split sprocket 12 teeth

(for chains series 879, 879 TAB, 880, 880 TAB)

Part. **456**

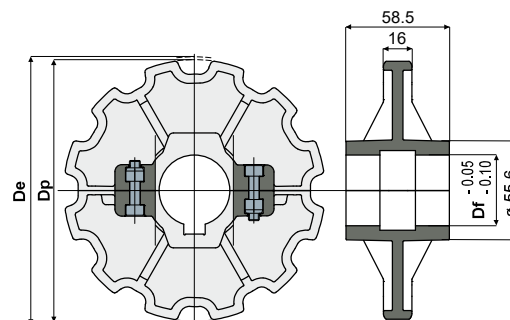

Df (mm)	Dp (mm)	De (mm)	Code
25	147,2	147,4	456 / 85424
30	147,2	147,4	456 / 85425
35	147,2	147,4	456 / 85426
40	147,2	147,4	456 / 85427

**MATERIALS:** Wheel made of reinforced polyamide black colour; screws made of stainless steel AISI 304, nuts in nickel plated brass.

**FEATURES:** Dimensions of the keyway UNI 6604-69 - DIN 6885/1.

To be used with chains Part.710, 711, 713.

**BOX QUANTITY:** 8 pieces.

**ON REQUEST:**

- Wheels: In other materials.
- Box quantity: According to your request.

# Idler wheels

## Part. 472 Split idler wheel 12 teeth (for chains series 882, 882 TAB)

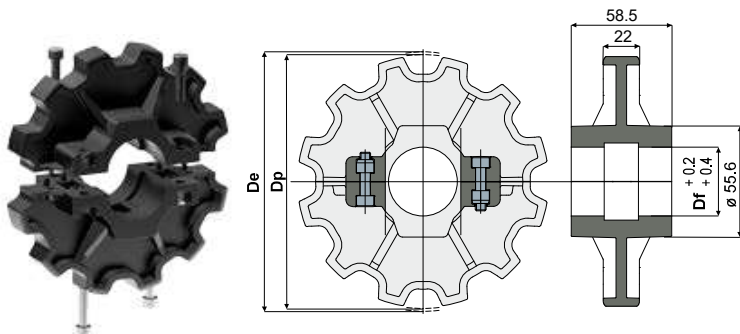

Df (mm)	Dp (mm)	De (mm)	Code
25	147,2	149	472 / 85969
30	147,2	149	472 / 85970
35	147,2	149	472 / 85971
40	147,2	149	472 / 85972

**MATERIALS:** Wheel made of polyamide black colour; screws made of stainless steel AISI 304, nuts in nickel plated brass.

**BOX QUANTITY:** 8 pieces.

**ON REQUEST:**

- Wheels: In other materials.
- Box quantity: According to your request.

## Part. 473 Split sprocket 12 teeth (for chains series 882, 882 TAB)

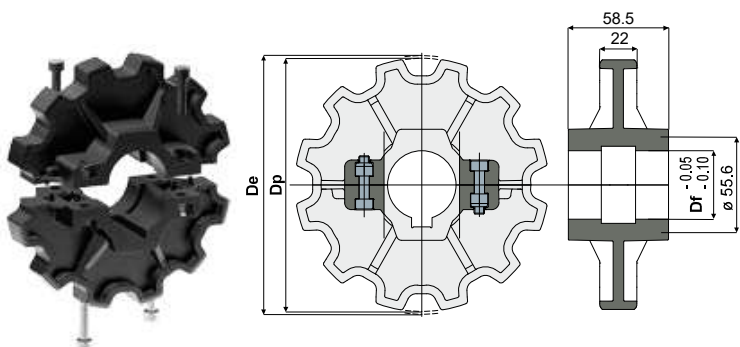

Df (mm)	Dp (mm)	De (mm)	Code
25	147,2	149	473 / 85973
30	147,2	149	473 / 85974
35	147,2	149	473 / 85975
40	147,2	149	473 / 85976

**MATERIALS:** Wheel made of reinforced polyamide black colour; screws made of stainless steel AISI 304, nuts in nickel plated brass.

**FEATURES:** Dimensions of the keyway UNI 6604-69 - DIN 6885/1.

**BOX QUANTITY:** 8 pieces.

**ON REQUEST:**

- Wheels: In other materials.
- Box quantity: According to your request.

### Example of application

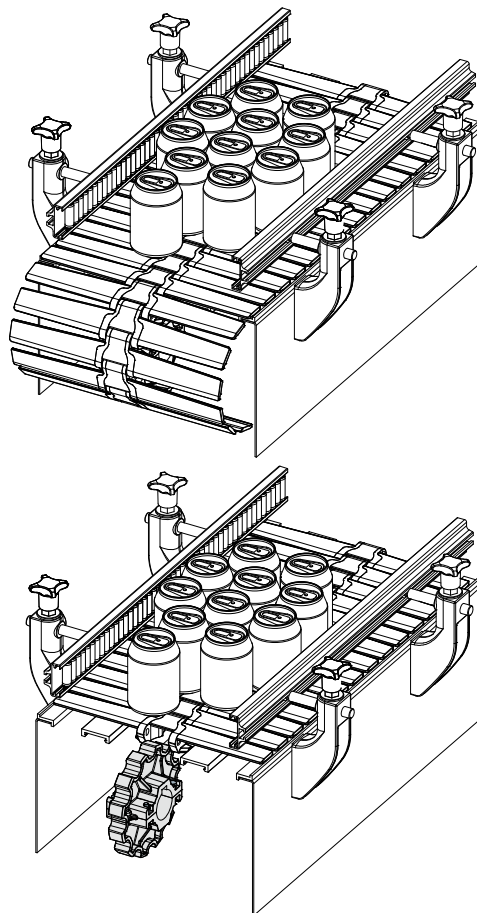

# Idler wheels

Example of application

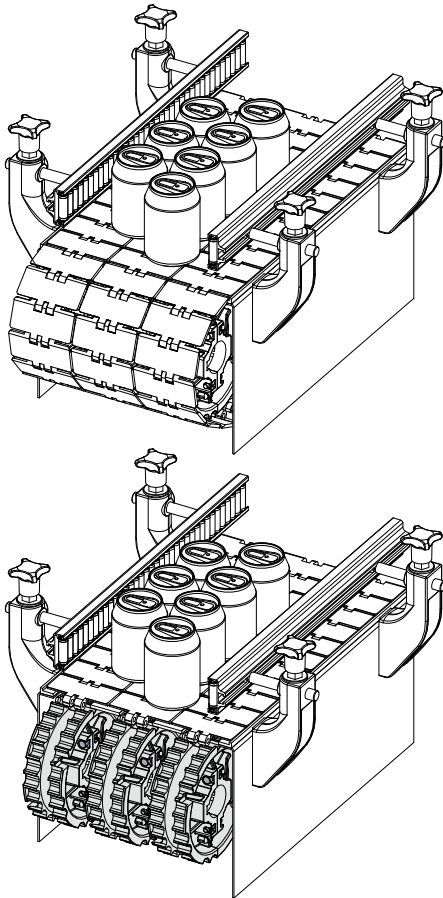

## Split idler wheel 25 teeth (for chains series 815, 820, 831)

Part. **535**

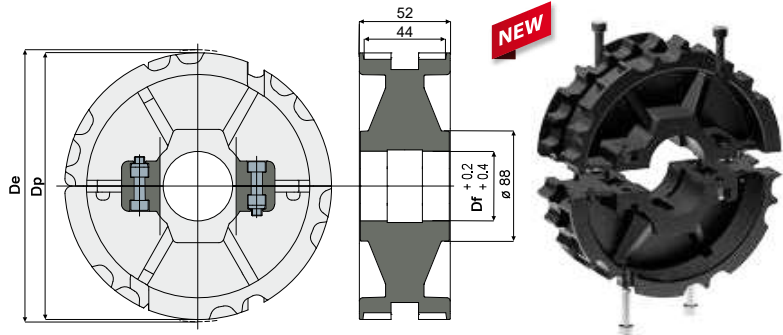

Df (mm)	Dp (mm)	De (mm)	Code
25	153,2	153	535 / 88680
30	153,2	153	535 / 88681
35	153,2	153	535 / 88682
40	153,2	153	535 / 88683

**MATERIALS:** Wheel made of polyamide black colour; screws made of stainless steel AISI 304, nuts in nickel plated brass.

**BOX QUANTITY:** 8 pieces.

**ON REQUEST:**

- Wheels: In other materials.
- Box quantity: According to your request.

## Split sprocket 25 teeth (for chains series 815, 820, 831)

Part. **523**

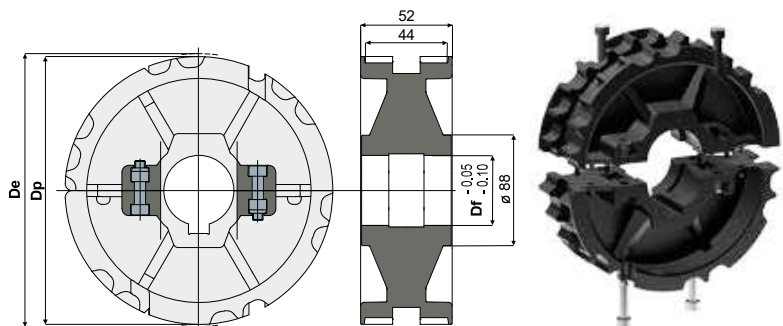

Df (mm)	Dp (mm)	De (mm)	Code
25	153,2	153	523 / 87357
30	153,2	153	523 / 87358
35	153,2	153	523 / 87359
40	153,2	153	523 / 87360

**MATERIALS:** Wheel made of reinforced polyamide black colour; screws made of stainless steel AISI 304, nuts in nickel plated brass.

**FEATURES:** Dimensions of the keyway UNI 6604-69 - DIN 6885/1.

**BOX QUANTITY:** 8 pieces.

**ON REQUEST:**

- Wheels: In other materials.
- Box quantity: According to your request.

# Idler wheels

Part. **458**

## Corner disc 32 teeth

(for chains series 879 BO, 879 TAB BO, 880 BO, 880 TAB BO)

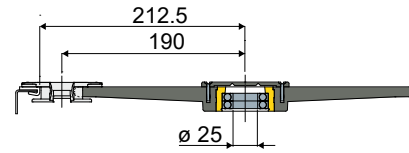
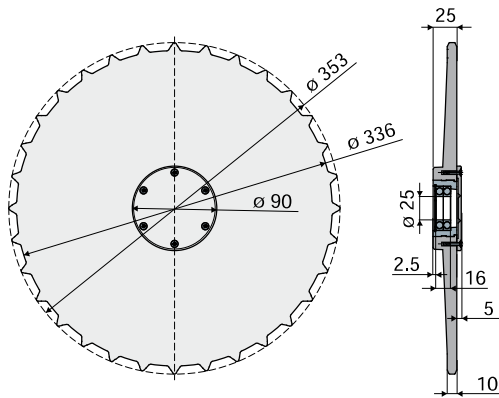

### Example of application

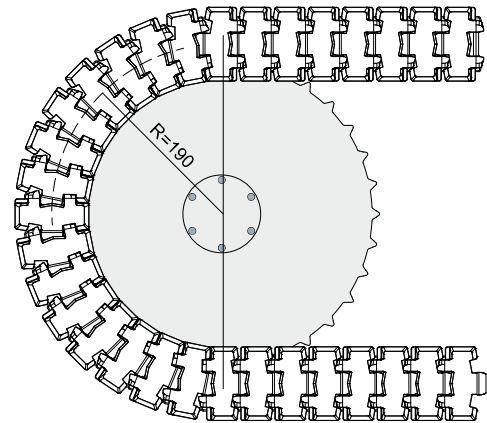

Code
458 / 85435

**MATERIALS:** Wheel and external cap made of reinforced polyamide black colour; bushing in brass; stop ring and self-threading screws in stainless steel AISI 304; bearing type 16005 25x47x8 in chrome steel.

**FEATURES:** To be used with chains Part.710, 711, 713.

**BOX QUANTITY:** 2 pieces.

**ON REQUEST:**

- Wheels: In other materials.
- Box quantity: According to your request.

# Idler wheels

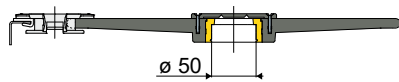

## Example of application

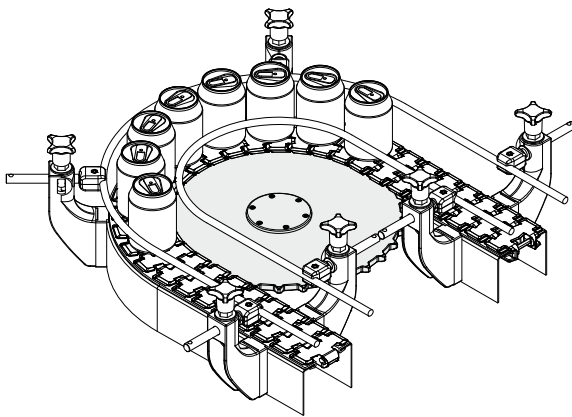

## Corner disc 32 teeth

(for chains series 879 BO, 879 TAB BO, 880 BO, 880 TAB BO)

## Part. 459

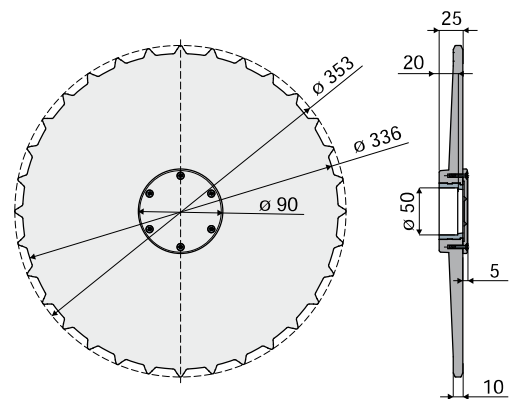

Code
459 / 85436

**MATERIALS:** Wheel and external cap made of reinforced polyamide black colour; bushing in brass; self-threading screws in stainless steel AISI 304.

**FEATURES:** To be used with chains Part.710, 711, 713.

**BOX QUANTITY:** 2 pieces.

**ON REQUEST:**

- **Wheels:** In other materials.
- **Box quantity:** According to your request.

# Chain guides and accessories

## Part. 381 Chain guide profile

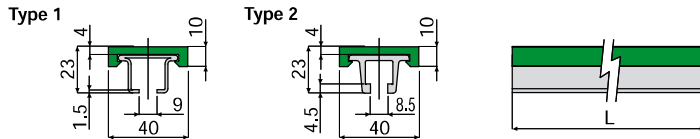

Type 1				Type 2		
Metal profile in stainless steel AISI 304		Metal profile in stainless steel AISI 430		Metal profile in anodized aluminium		
Code	Code	Colour	L	Code	Colour	L
381 / 84085	381 / 84086	Green	3 Mt.	381 / 84474	Green	3 Mt.
381 / 84954	381 / 84955	Green	6 Mt.	381 / 84475	Green	6 Mt.
381 / 84942	381 / 84946	White	3 Mt.	381 / 84944	White	3 Mt.
381 / 84943	381 / 84947	White	6 Mt.	381 / 84945	White	6 Mt.
381 / 84948	381 / 84952	Black	3 Mt.	381 / 84950	Black	3 Mt.
381 / 84949	381 / 84953	Black	6 Mt.	381 / 84951	Black	6 Mt.
381 / 88130	381 / 88129	Blue Ral 5005	3 Mt.	381 / 87424	Blue Ral 5005	3 Mt.
381 / 88131	381 / 88124	Blue Ral 5005	6 Mt.	381 / 85541	Blue Ral 5005	6 Mt.

NEW  
NEW

**MATERIALS:** Metal profile in stainless steel AISI 304, AISI 430 or anodized aluminium; guide profile in polyethylene.

**FEATURES:** Supplied in lengths of 3 or 6 Mt.

**BOX QUANTITY:**

- 3 Mt. lengths version: This item is sold in Mt. - Min. 6 Mt. (2 lengths);
- 6 Mt. lengths version: This item is sold in Mt. - Min. 12 Mt. (2 lengths).

**ON REQUEST:**

- Guide profiles: In antistatic material black colour.
- Box quantity: According to your request.

### Example of application

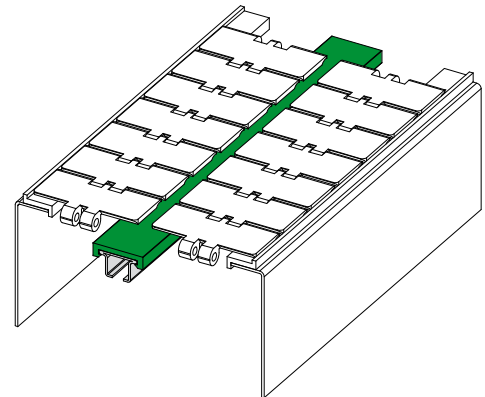

## Part. 384 Chain guide profile

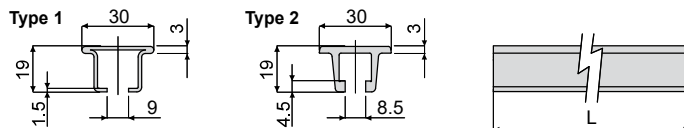

Type 1			Type 2	
Metal profile in stainless steel AISI 304		Metal profile in stainless steel AISI 430	Metal profile in anodized aluminium	
Code	Code	L	Code	L
384 / 84121	384 / 84122	3 Mt.	384 / 84476	3 Mt.
384 / 84956	384 / 84957	6 Mt.	384 / 84477	6 Mt.

**MATERIALS:** Metal profile in stainless steel AISI 304, AISI 430 or anodized aluminium.

**FEATURES:** Supplied in lengths of 3 or 6 Mt.

**BOX QUANTITY:**

- 3 Mt. lengths version: This item is sold in Mt. - Min. 6 Mt. (2 lengths);
- 6 Mt. lengths version: This item is sold in Mt. - Min. 12 Mt. (2 lengths).

**ON REQUEST:**

- Box quantity: According to your request.

# Chain guides and accessories

## Chain guide profile Part. 385

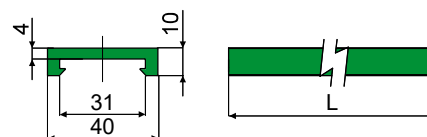

Code	Colour	L
385 / 84123	Green	3 Mt.
385 / 84478	Green	6 Mt.
385 / 84940	White	3 Mt.
385 / 84577	White	6 Mt.
385 / 84941	Black	3 Mt.
385 / 84578	Black	6 Mt.
385 / 88127	Blue Ral 5005	3 Mt.
385 / 88128	Blue Ral 5005	6 Mt.



**MATERIALS:** Guide profile in polyethylene.  
**FEATURES:** Supplied in lengths of 3 or 6 Mt.

**BOX QUANTITY:**

- 3 Mt. lengths version: This item is sold in Mt. - Min. 6 Mt. (2 lengths);
- 6 Mt. lengths version: This item is sold in Mt. - Min. 12 Mt. (2 lengths).

**ON REQUEST:**

- Guide profiles: In antistatic material black colour.
- Box quantity: According to your request.

**Example of application**

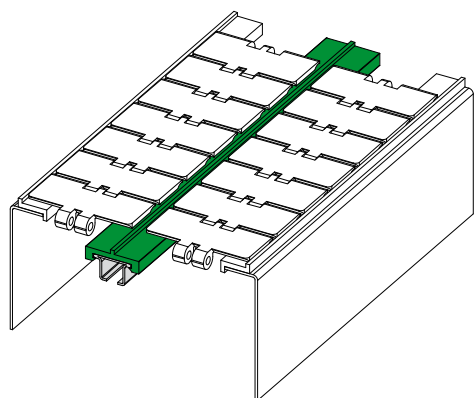

## Chain guide profile Part. 513

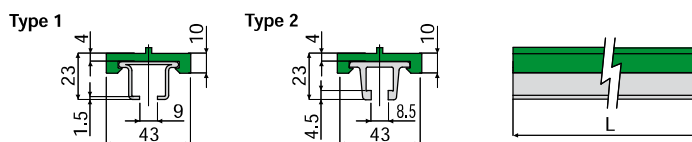

Type 1				Type 2		
Metal profile in stainless steel AISI 304		Metal profile in stainless steel AISI 430		Metal profile in anodized aluminium		
Code	Code	Colour	L	Code	Colour	L
513 / 87081	513 / 87083	Green	3 Mt.	513 / 87085	Green	3 Mt.
513 / 87082	513 / 87084	Green	6 Mt.	513 / 87086	Green	6 Mt.

**MATERIALS:** Metal profile in stainless steel AISI 304, AISI 430 or anodized aluminium; guide profile in polyethylene.

**FEATURES:** Supplied in lengths of 3 or 6 Mt.

**BOX QUANTITY:**

- 3 Mt. lengths version: This item is sold in Mt. - Min. 6 Mt. (2 lengths);
- 6 Mt. lengths version: This item is sold in Mt. - Min. 12 Mt. (2 lengths).

**ON REQUEST:**

- Guide profiles: In antistatic material black colour.
- Box quantity: According to your request.



# Chain guides and accessories

## Part. 512 Chain guide profile

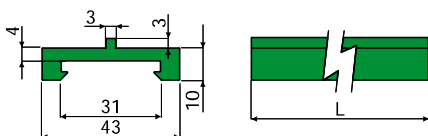

Code	Colour	L
512 / 87079	Green	3 Mt.
512 / 87080	Green	6 Mt.

**MATERIALS:** Guide profile in polyethylene.

**FEATURES:** Supplied in lengths of 3 or 6 Mt.

**BOX QUANTITY:**

- 3 Mt. lengths version: This item is sold in Mt. - Min. 6 Mt. (2 lengths);
- 6 Mt. lengths version: This item is sold in Mt. - Min. 12 Mt. (2 lengths).

**ON REQUEST:**

- Guide profiles: In antistatic material black colour.
- Box quantity: According to your request.

## Part. 517 Chain guide profile (with rectified sliding surface)

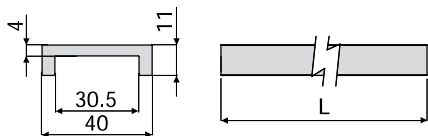

Code	Colour	L
517 / 87377	Black	3 Mt.
517 / 87378	Black	6 Mt.

**MATERIALS:** Guide profile in polyethylene.

**FEATURES:** Rectified sliding surface. Supplied in lengths of 3 or 6 Mt.

**BOX QUANTITY:**

- 3 Mt. lengths version: This item is sold in Mt. - Min. 6 Mt. (2 lengths);
- 6 Mt. lengths version: This item is sold in Mt. - Min. 12 Mt. (2 lengths).

**ON REQUEST:**

- Guide profiles: In antistatic material black colour.
- Box quantity: According to your request.

### Example of application

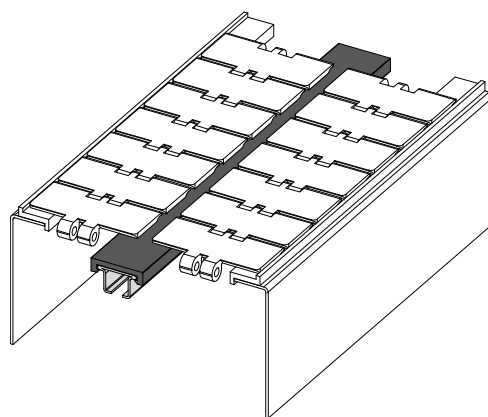

# Chain guides and accessories

Example of application

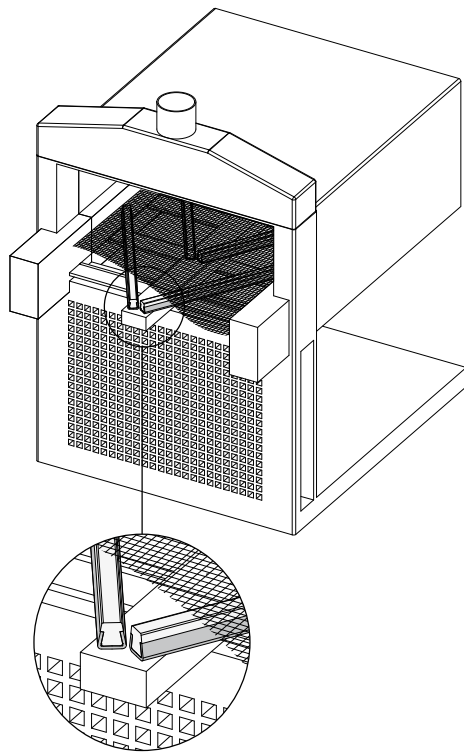

## Guide rail for high temperatures (with metal profile)

Part. **377**



Operating temperatures up to 260°C

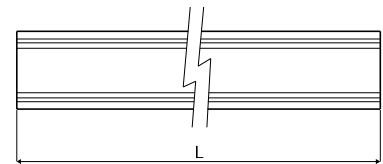
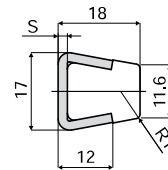

Code	S	L
377 / 85476	1,5	3 Mt.
377 / 83973	2	3 Mt.

**MATERIALS:** Guide profile in PTFE (Teflon) natural colour; metal profile in stainless steel AISI 304.  
**FEATURES:** To be used in every application where the resistance to the high temperatures is needed; for example: ovens, fryers, filling areas with high temperature, steam rooms, kitchens etc. Supplied in 3 meters lengths. Min. curvature radius: 145 mm.

**BOX QUANTITY:** 2 bars of 3 meters (total 6 meters).

**ON REQUEST:**

- Box quantity: According to your request.

# Chain guides and accessories

Part. **444**

**Chain inlet guide shoe**  
(side)

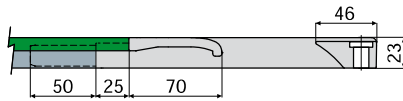

Right Version

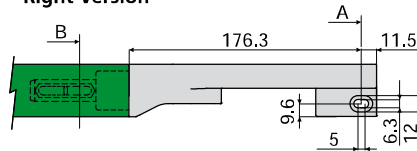

Left Version

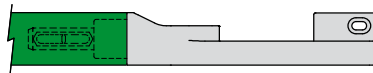

Section B

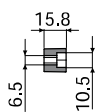

Section A

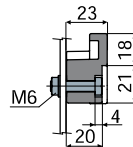

Version	Code
Right	444 / 85308
Left	444 / 85309

**MATERIALS:** Shoe in black polyamide.

**FEATURES:** To be assembled near to the idler wheels to drive the chain on the transport guides: Part.381, 384, 513 (excluding versions with aluminium metal profile).

**BOX QUANTITY:** 24 pieces.

**ON REQUEST:**

- Shoes: In various colours.
- Box quantity: According to your request.

Example of application

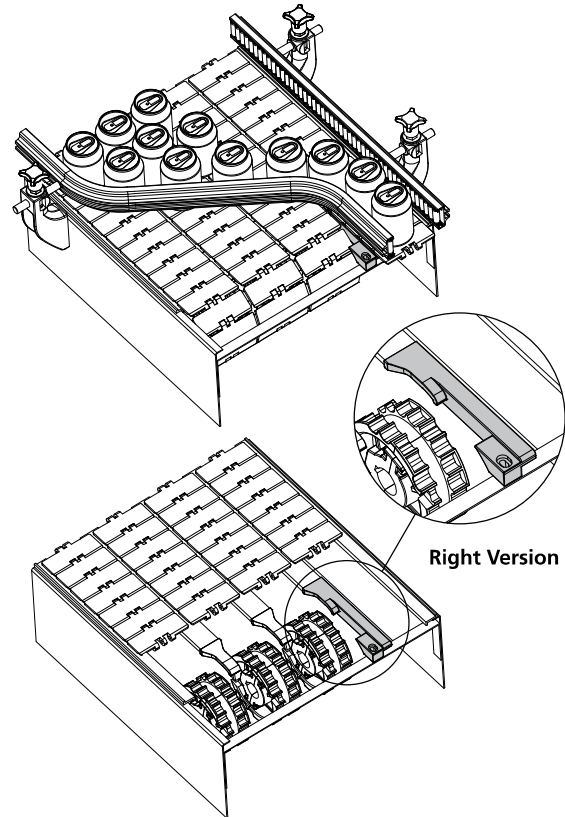

Right Version

Part. **389**

**Chain inlet guide shoe**  
(central)

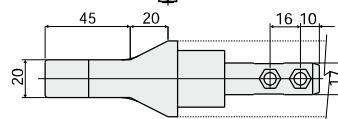
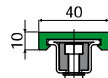
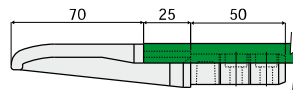

Code

389 / 84165

**MATERIALS:** Shoe in black polyamide.

**FEATURES:** To be assembled near to the idler wheels to drive the chain on the transport guides: Part.381, 384, 513 (excluding versions with aluminium metal profile).

**BOX QUANTITY:** 24 pieces.

**ON REQUEST:**

- Shoes: In various colours.
- Box quantity: According to your request.

Example of application

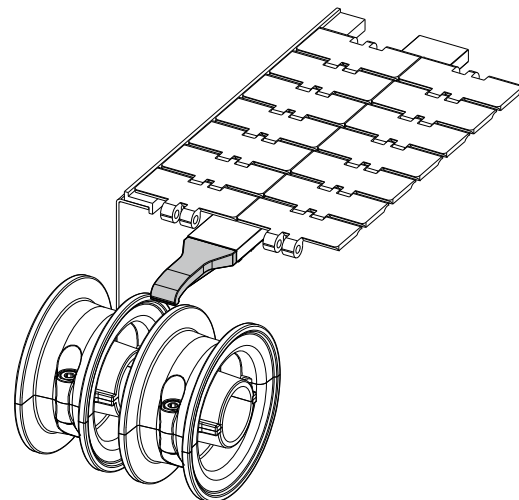

# Chain guides and accessories

Example of application

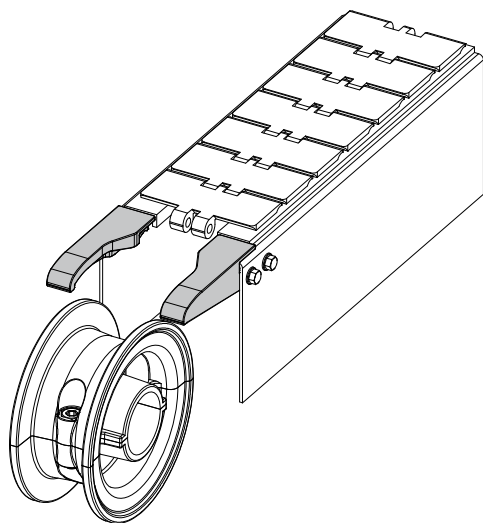

## Chain inlet guide shoe

Part. **519**

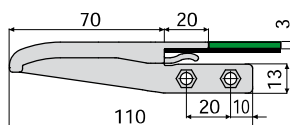

Left Version

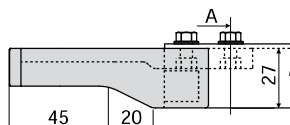

Right Version

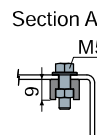
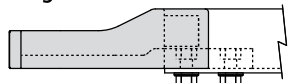

Version	Code
Right	519 / 87254
Left	519 / 87255
Right + Left	519 / 87256

**MATERIALS:** Shoe in black polyamide.

**FEATURES:** To be assembled near to the idler wheels to drive the chain on the transport guides: Part.381, 384, 513 (excluding versions with aluminium metal profile).

**BOX QUANTITY:** 24 pieces.

**ON REQUEST:**

- Shoes: In various colours.
- Box quantity: According to your request.

Example of application

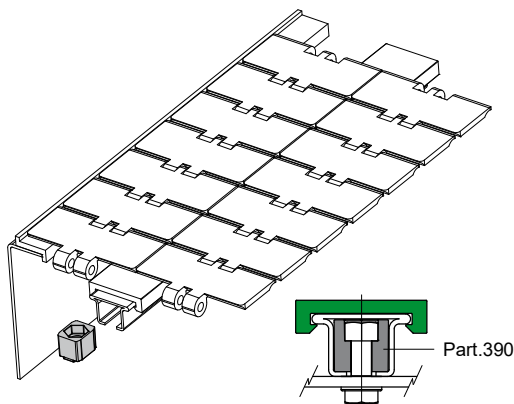

## Mounting block for chain guide profile

Part. **390**

Type 1

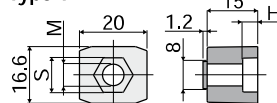

Type 2

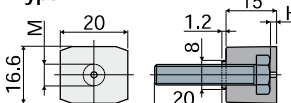

Type 1				Type 2		
Code	M	H	S	Code	M	H
390 / 84166	M6	4,5	10	390 / 87189	M6	2
390 / 84167	M8	6	13			

**MATERIALS:** Mounting block in reinforced polyamide, black colour; screw in stainless steel.

**FEATURES:** To be used for the guide fixing on the frame: Part.381, 384, 513 (excluding versions with aluminium metal profile).

**BOX QUANTITY:** 96 pieces.

**ON REQUEST:**

- Mounting blocks: In various colours.
- Box quantity: According to your request.

Example of application

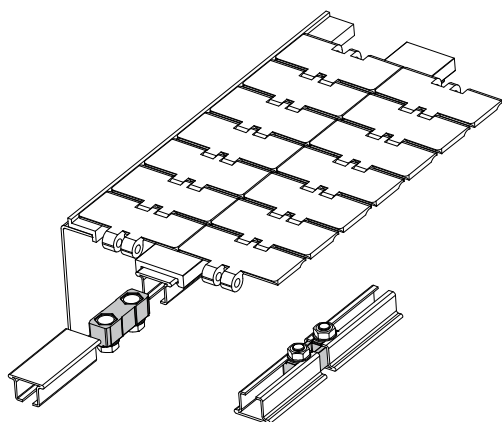

## Connecting block for chain guide profile

Part. **391**

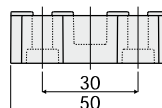
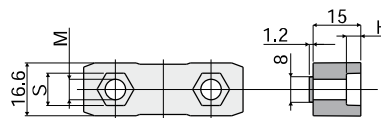

Code	M	H	S
391 / 84168	M6	4,5	10
391 / 84169	M8	6	13

**MATERIALS:** Connecting block in reinforced polyamide, black colour.

**FEATURES:** To be used to joint the guides: Part.381, 384, 513 (excluding versions with aluminium metal profile).

**BOX QUANTITY:** 48 pieces.

**ON REQUEST:**

- Connecting blocks: In various colours.
- Box quantity: According to your request.

# Chain guides and accessories

## Part. 461 Hinge joint

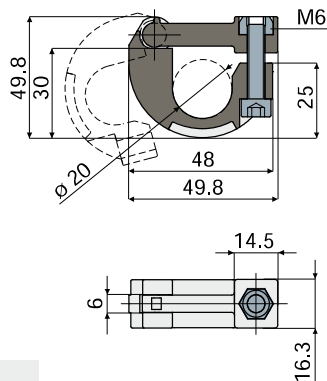

Code  
461 / 85473

**MATERIALS:** Joint in reinforced polyamide black colour; bolts and nuts in stainless steel AISI 304.

**FEATURES:** To be used to join the guides Part.381, 384, 513 (excluding versions with aluminium metal profile); supplied complete with bolts and nuts.

**BOX QUANTITY:** 8 pieces.

**ON REQUEST:**

- Joints: In other colours.
- Box quantity: According to your request.

## Part. 492 Closing cap (for chain guide profile Part.381)

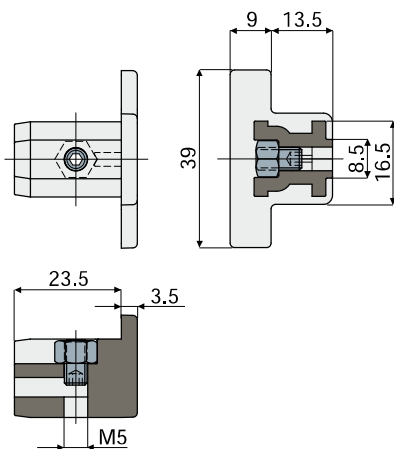

Code  
492 / 87013

**MATERIALS:** Cap in reinforced polyamide grey colour; nut and grub screw in stainless steel AISI 304.

**FEATURES:** To be used as a closure cap at the extremities of the central guides Part.381, 384, 513 (excluding versions with aluminium metal profile).

**BOX QUANTITY:** 24 pieces.

**ON REQUEST:**

- Assembling of: Nuts and grub screws.
- Box quantity: According to your request.

### Example of application

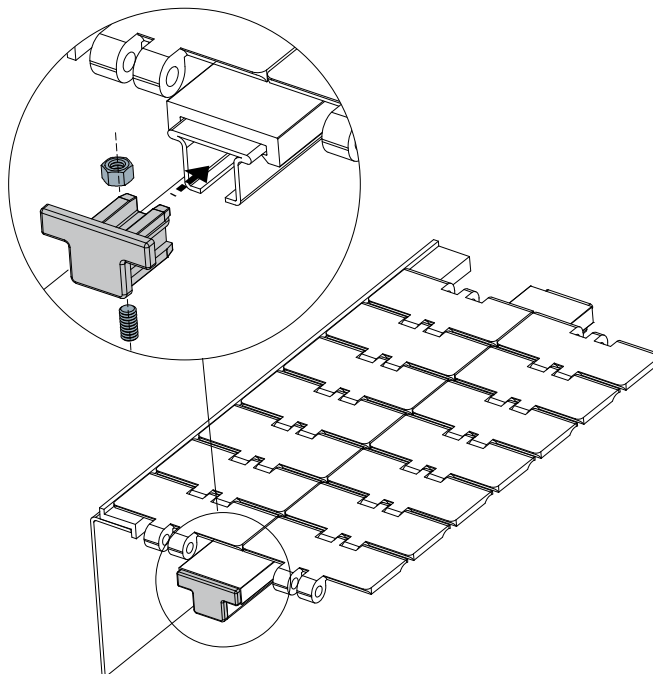
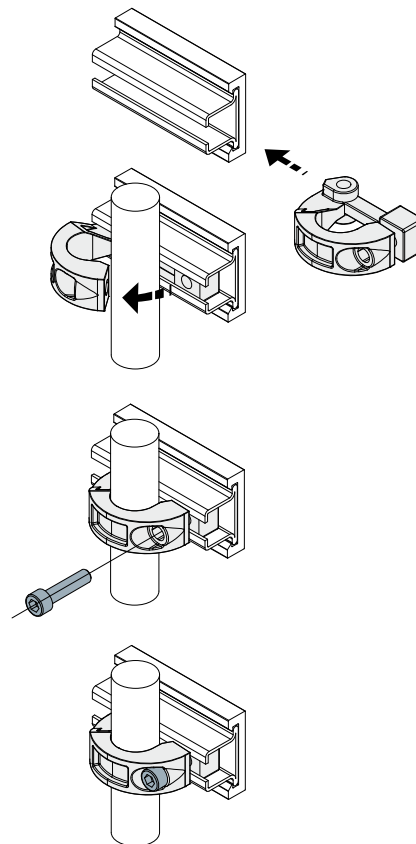

### Example of application

# Chain guides and accessories

Example of application

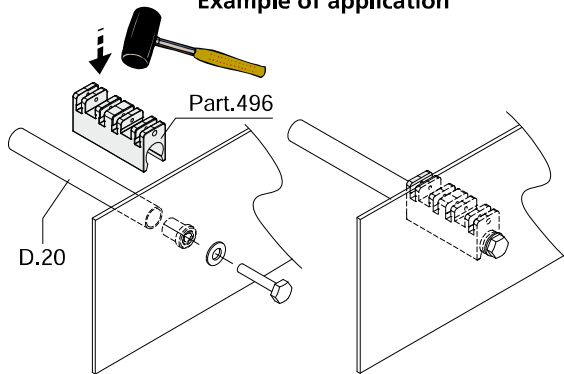

Example of application

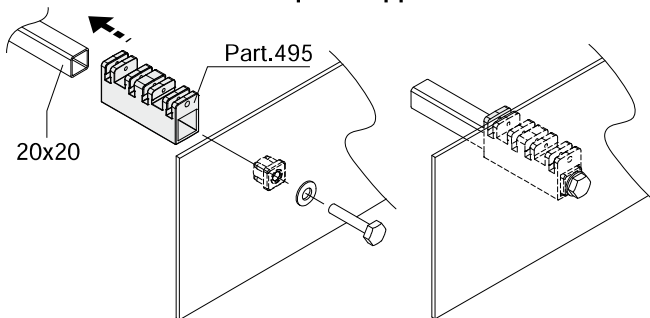

Example of application

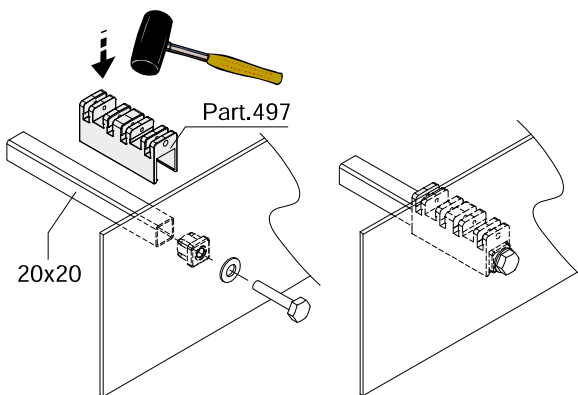

## Spacer for chain return (open version, for round tubes)

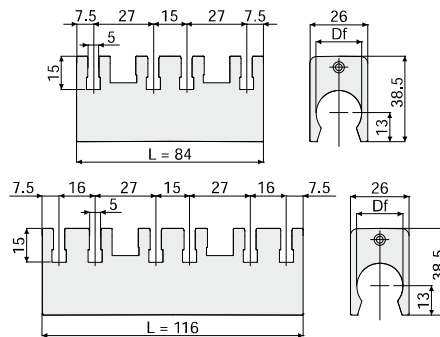

Df Bore for round tubes of (mm)	L	Code
20	84	496 / 87017
	116	496 / 87018

- MATERIALS:** Spacer in polyamide black colour.  
**FEATURES:** To be used together with the sliding profile Part.499.  
**BOX QUANTITY:** 24 pieces.  
**ON REQUEST:**
- Spacers: In various colours.
  - Box quantity: According to your request.



## Spacer for chain return (closed version, for square tubes)

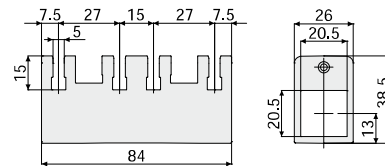

Code
495 / 87016

- MATERIALS:** Spacer in polyamide black colour.  
**FEATURES:** To be used together with the sliding profile Part.499.  
**BOX QUANTITY:** 24 pieces.  
**ON REQUEST:**
- Spacers: In various colours.
  - Box quantity: According to your request.



## Spacer for chain return (open version, for square tubes)

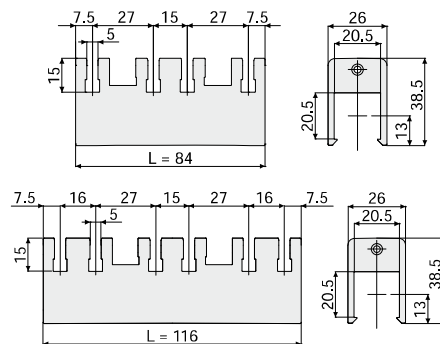

Df Bore for square tubes of (mm)	L	Code
20x20	84	497 / 87019
	116	497 / 87020

- MATERIALS:** Spacer in polyamide black colour.  
**FEATURES:** To be used together with the sliding profile Part.499.  
**BOX QUANTITY:** 24 pieces.  
**ON REQUEST:**
- Spacers: In various colours.
  - Box quantity: According to your request.



# Chain guides and accessories

## Part. 471

### Shoe for chain return

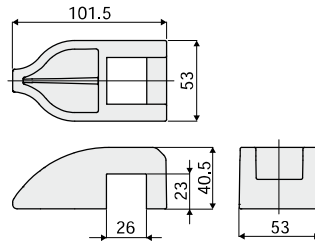

Code
471 / 85796

- MATERIALS:** Shoe is made of HD polyethylene green colour.  
**FEATURES:** To be used together with the spacers Part.495, 496, 497 and with the profile Part.499. Pressure mounting.  
**BOX QUANTITY:** 24 pieces.  
**ON REQUEST:**
- Shoes: In various colours.
  - Box quantity: According to your request.

## Part. 498 Striker

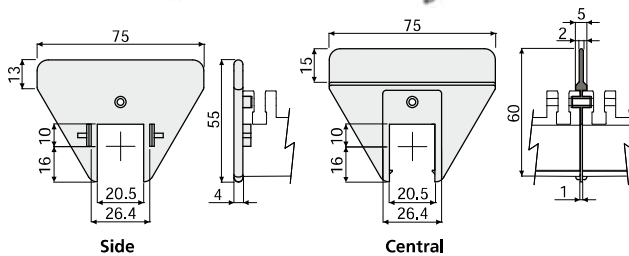

Type	Code
Side	498 / 87021
Central	498 / 87022

- MATERIALS:** Striker in polyamide black colour.  
**FEATURES:** To be used together with the spacers Part.495, 496, 497.  
**BOX QUANTITY:** 24 pieces.  
**ON REQUEST:**
- Strikers: In various colours.
  - Box quantity: According to your request.

## Part. 499 Sliding profile

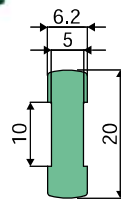

Code
499 / 87023

- MATERIALS:** Extruded polyethylene green colour.  
**FEATURES:** To be used together with the spacers Part.495, 496, 497.  
**BOX QUANTITY:** This item is sold in Mt. - Min. 60 Mt.  
**ON REQUEST:**
- Profiles: Different colours and lengths.
  - Box quantity: According to your request.

### Example of application

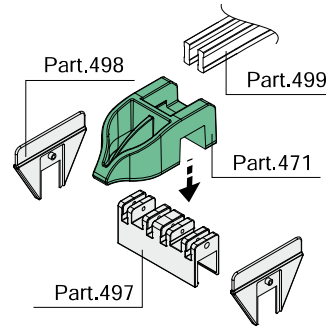

### Example of application

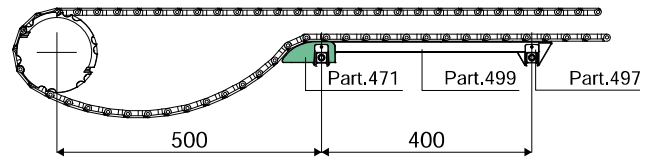

### Example of application

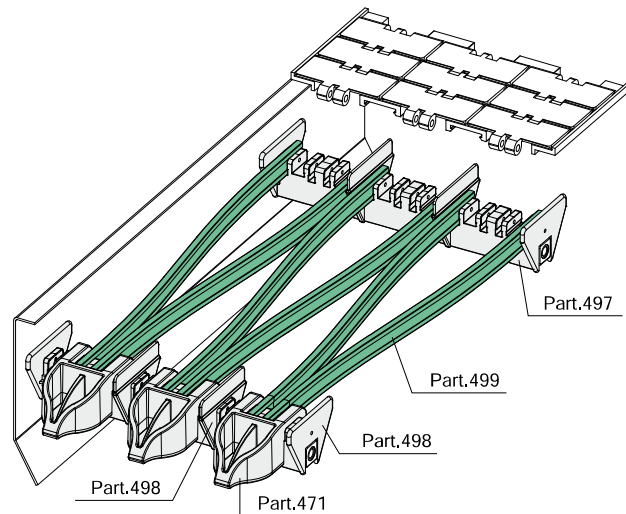

### Example of mounting

#### Chain width 82,5 mm

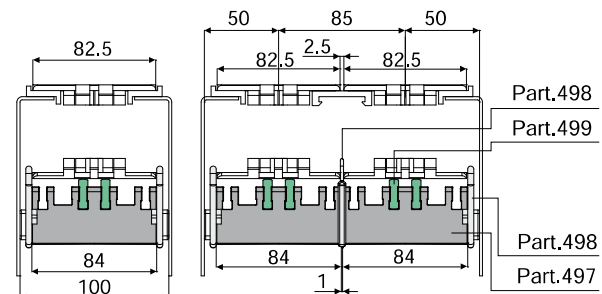

#### Chain width 114,3 mm

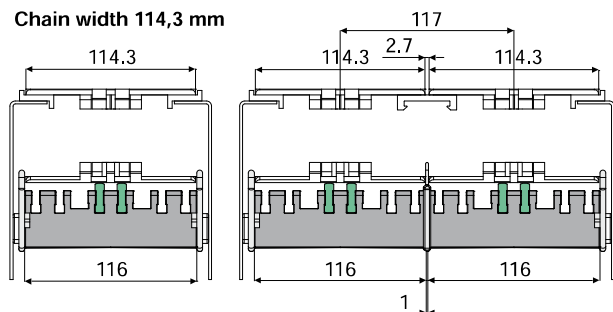

# Chain guides and accessories

Part. **361** Extruded profile supplied in coils of 50 / 60 Mt. For plates from 2 to 4 mm.

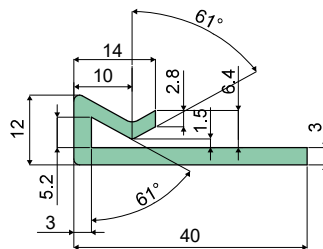

Code  
361 / 83717

MATERIALS: Extruded UHMWPE green colour.  
BOX QUANTITY: This item is sold in Mt. - Min. 50 Mt.  
ON REQUEST:  
• Guide profiles: Different colours and lengths.

Part. **362** Extruded profile supplied in coils of 60 Mt. For plates from 2 to 4 mm.

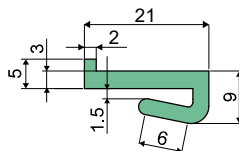

Code  
362 / 83718

MATERIALS: Extruded UHMWPE green colour.  
BOX QUANTITY: This item is sold in Mt. - Min. 60 Mt.  
ON REQUEST:  
• Guide profiles: Different colours and lengths.

Part. **363** Extruded profile supplied in coils of 60 Mt. For plates from 2 to 4 mm.

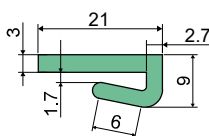

Code  
363 / 83719

MATERIALS: Extruded UHMWPE green colour.  
BOX QUANTITY: This item is sold in Mt. - Min. 60 Mt.  
ON REQUEST:  
• Guide profiles: Different colours and lengths.

Part. **364** Extruded chain guide profiles for flat 30x3 mm. supplied in 3 Mt. Lengths

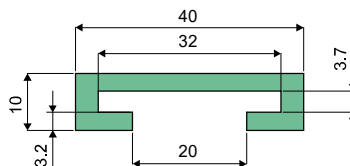

Code  
364 / 83720

MATERIALS: Extruded UHMWPE green colour.  
BOX QUANTITY: This item is sold in Mt. - Min. 6 Mt. (2 lengths).  
ON REQUEST:  
• Guide profiles: Different colours and lengths.



# Chain guides and accessories

## Extruded chain guide profiles for flat 40x6 mm. supplied in 3 / 6 Mt. Lengths

Part. **365**

Code	Length
365 / 84087	3 Mt. <b>NEW</b>
365 / 83721	6 Mt.

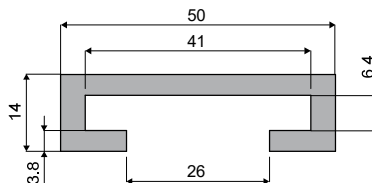

MATERIALS: Extruded UHMWPE black colour.

BOX QUANTITY:

- 3 Mt. lengths version: This item is sold in Mt. - Min. 6 Mt. (2 lengths);
- 6 Mt. lengths version: This item is sold in Mt. - Min. 12 Mt. (2 lengths).

ON REQUEST:

- Guide profiles: Different colours and lengths.

## Extruded chain guide profiles for flat 50x6 mm. supplied in 3 / 6 Mt. Lengths

Part. **366**

Code	Length
366 / 84239	3 Mt. <b>NEW</b>
366 / 83722	6 Mt.

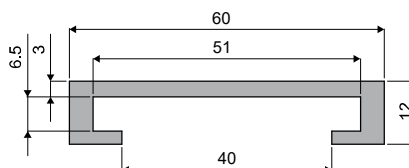

MATERIALS: Extruded UHMWPE black colour.

BOX QUANTITY:

- 3 Mt. lengths version: This item is sold in Mt. - Min. 6 Mt. (2 lengths);
- 6 Mt. lengths version: This item is sold in Mt. - Min. 12 Mt. (2 lengths).

ON REQUEST:

- Guide profiles: Different colours and lengths.

## Extruded chain guide profiles supplied in coils of 60 Mt.

Part. **367**

Code
367 / 83723

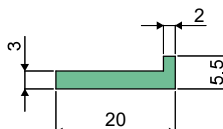

MATERIALS: Extruded UHMWPE green colour.

BOX QUANTITY: This item is sold in Mt. - Min. 60 Mt.

ON REQUEST:

- Guide profiles: Different colours and lengths.

## Extruded chain guide profiles supplied in coils of 60 Mt.

Part. **368**

Code
368 / 83724

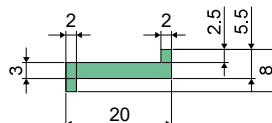

MATERIALS: Extruded UHMWPE green colour.

BOX QUANTITY: This item is sold in Mt. - Min. 60 Mt.

ON REQUEST:

- Guide profiles: Different colours and lengths.

## Extruded chain guide profiles supplied in coils of 50 Mt. For plates from 6 to 7 mm.

Part. **369**

Code
369 / 83725

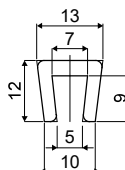

MATERIALS: Extruded UHMWPE white colour.

BOX QUANTITY: This item is sold in Mt. - Min. 50 Mt.

ON REQUEST:

- Guide profiles: Different colours and lengths.