

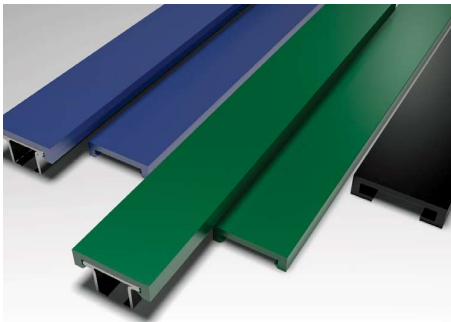



# GENERAL CATALOGUE 2023









**teCom**  
Technology Components

### Bases

			
Part. 200	Part. 201	Part. 202	Part. 203
pag. 10	pag. 10	pag. 11	pag. 11

### Bearing heads

					
Part. 212	Part. 208	Part. 211	Part. 207	Part. 409	Part. 402
pag. 12	pag. 12	pag. 13	pag. 13	pag. 14	pag. 14



### Connecting joints

				
Part. 210	Part. 210	Part. 403	Part. 404	Part. 401
pag. 15	pag. 15	pag. 16	pag. 16	pag. 16

### Guide rail brackets

						
Part. 213	Part. 214	Part. 215	Part. 243	Part. 280	Part. 281	Part. 279
pag. 17	pag. 17	pag. 18	pag. 18	pag. 19	pag. 19	pag. 20
						
Part. 216	Part. 218	Part. 244	Part. 488	Part. 489	Part. 490	Part. 491
pag. 20	pag. 21	pag. 21	pag. 22	pag. 22	pag. 23	pag. 23
						
Part. 255	Part. 219	Part. 217	Part. 209	Part. 220	Part. 242	Part. 486
pag. 24	pag. 24	pag. 25	pag. 25	pag. 26	pag. 26	pag. 27
						
Part. 487	Part. 224	Part. 225	Part. 530	Part. 236	Part. 235	Part. 387
pag. 27	pag. 28	pag. 28	pag. 28	pag. 29	pag. 29	pag. 30
						
Part. 392	Part. 436	Part. 408	Part. 408	Part. 442	Part. 441	
pag. 30	pag. 30	pag. 31	pag. 31	pag. 32	pag. 32	























### Tightening eyebolts

	Part. 406	pag. 33		Part. 407	pag. 33
---	-----------	---------	---	-----------	---------

### Heads for brackets

	Part. 222	pag. 34		Part. 221	pag. 34		Part. 266	pag. 34		Part. 223	pag. 35		Part. 256	pag. 35		Part. 526	pag. 35
---	-----------	---------	---	-----------	---------	---	-----------	---------	---	-----------	---------	---	-----------	---------	---	-----------	---------

### Knobs and handles

	Part. 226	pag. 36		Part. 227	pag. 36		Part. 228	pag. 36		Part. 246	pag. 37		Part. 247	pag. 37		Part. 248	pag. 37		Part. 313	pag. 38		Part. 314	pag. 38
	Part. 315	pag. 38		Part. 386	pag. 39		Part. 334	pag. 39		Part. 337	pag. 39		Part. 338	pag. 39		Part. 382	pag. 40		Part. 383	pag. 40		Part. 350	pag. 40
	Part. 294	pag. 40		Part. 303	pag. 41		Part. 304	pag. 41		Part. 305	pag. 41		Part. 397	pag. 42		Part. 400	pag. 42		Part. 332	pag. 42			

### Guide rail clamps

	Part. 230	pag. 43		Part. 289	pag. 43		Part. 229	pag. 43		Part. 231	pag. 44		Part. 232	pag. 44		Part. 291	pag. 44		Part. 483	pag. 45		Part. 484	pag. 45
	Part. 290	pag. 45		Part. 346	pag. 46		Part. 347	pag. 46		Part. 348	pag. 47		Part. 349	pag. 47		Part. 301	pag. 48		Part. 460	pag. 48		Part. 398	pag. 48
	Part. 204	pag. 49		Part. 205	pag. 49		Part. 412	pag. 50		Part. 413	pag. 50		Part. 521	pag. 50		Part. 410	pag. 51		Part. 411	pag. 51		Part. 405	pag. 51
	Part. 424	pag. 52		Part. 443	pag. 52		Part. 440	pag. 53		Part. 439	pag. 53		Part. 470	pag. 54		Part. 531	pag. 54		Part. 427	pag. 55		Part. 434	pag. 55

# Connecting joints

## Connection joint for round tubes

Part. **210**

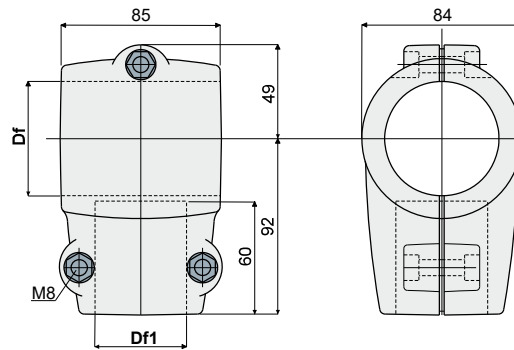

Df		Df1		Zinc plated bolts and nuts	Stainless steel AISI 304 bolts and nuts
Bore for tubes of (mm)	Bore for tubes of (Inches)	Bore for tubes of (mm)	Bore for tubes of (Inches)	Code	Code
60,3	2"	48,3	1" 1/2	210 / 80638	210 / 80639
60,3	2"	42,4	1" 1/4	210 / 80640	210 / 80641
48,3	1" 1/2	48,3	1" 1/2	210 / 80642	210 / 80643
48,3	1" 1/2	42,4	1" 1/4	210 / 80644	210 / 80645
42,4	1" 1/4	42,4	1" 1/4	210 / 80646	210 / 80647

**MATERIALS:** Joint made of reinforced polyamide black colour; bolts and nuts made of stainless steel AISI 304 or zinc plated steel.

**FEATURES:** Max tightening torque 2 Kg-m.

**BOX QUANTITY:** 8 pieces.

**ON REQUEST:**

- Joints: In reinforced polypropylene, other colours.
- Box quantity: According to your request.
- Assembling of: Bolts and nuts.

## Connection joint for square tubes

Part. **210**

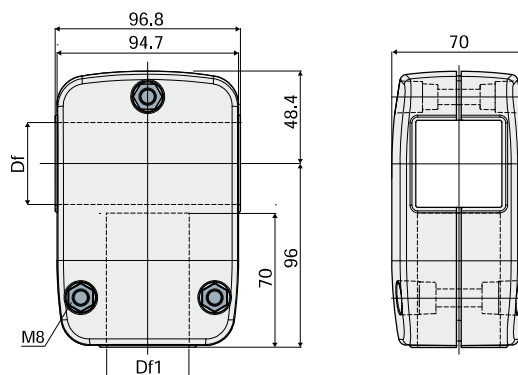

Df	Df1	Zinc plated bolts and nuts	Stainless steel AISI 304 bolts and nuts
Bore for tubes of (mm)	Bore for tubes of (mm)	Code	Code
40x40	40x40	210 / 85114	210 / 85115
45x45	45x45	210 / 84132	210 / 84133

**MATERIALS:** Joint made of reinforced polyamide black colour; bolts and nuts made of stainless steel AISI 304 or zinc plated steel.

**FEATURES:** Max tightening torque 2 Kg-m.

**BOX QUANTITY:** 8 pieces.

**ON REQUEST:**

- Joints: In reinforced polypropylene, other colours.
- Box quantity: According to your request.
- Assembling of: Bolts and nuts.



# Connecting joints

## Part. 403 Connection joint

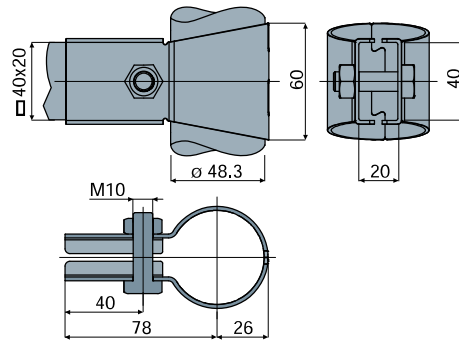

Code  
403 / 84325

MATERIALS: Joint, screw and nut made of stainless steel AISI 304.

FEATURES: Supplied complete with bolts and nuts.

BOX QUANTITY: 8 pieces.

ON REQUEST:

- Box quantity: According to your request.
- Assembly of: Bolts and nuts.

### Example of application

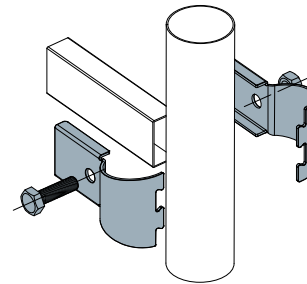

## Part. 404 Connection joint

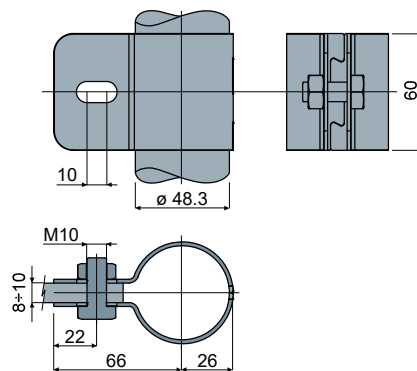

Code  
404 / 84326

MATERIALS: Joint, screw and nut made of stainless steel AISI 304.

FEATURES: Supplied complete with bolts and nuts.

BOX QUANTITY: 8 pieces.

ON REQUEST:

- Box quantity: According to your request.
- Assembly of: Bolts and nuts.

### Example of application

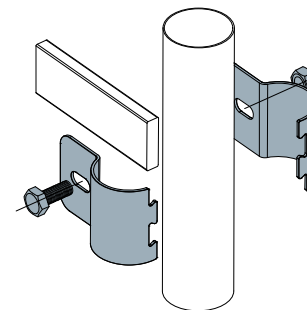

## Part. 401 Connection joint

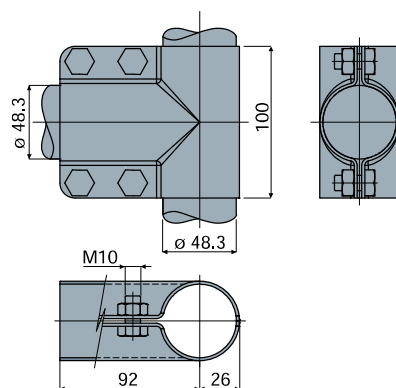

Code  
401 / 84323

MATERIALS: Joint, screws and nuts made of stainless steel AISI 304.

FEATURES: Supplied complete with bolts and nuts.

BOX QUANTITY: 8 pieces.

ON REQUEST:

- Box quantity: According to your request.
- Assembly of: Bolts and nuts.

### Example of application

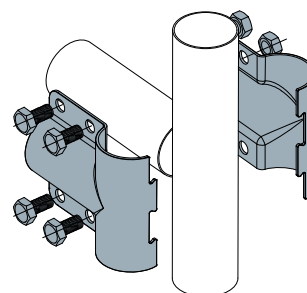

# Guide rail brackets

## Guide rail bracket Part. 213

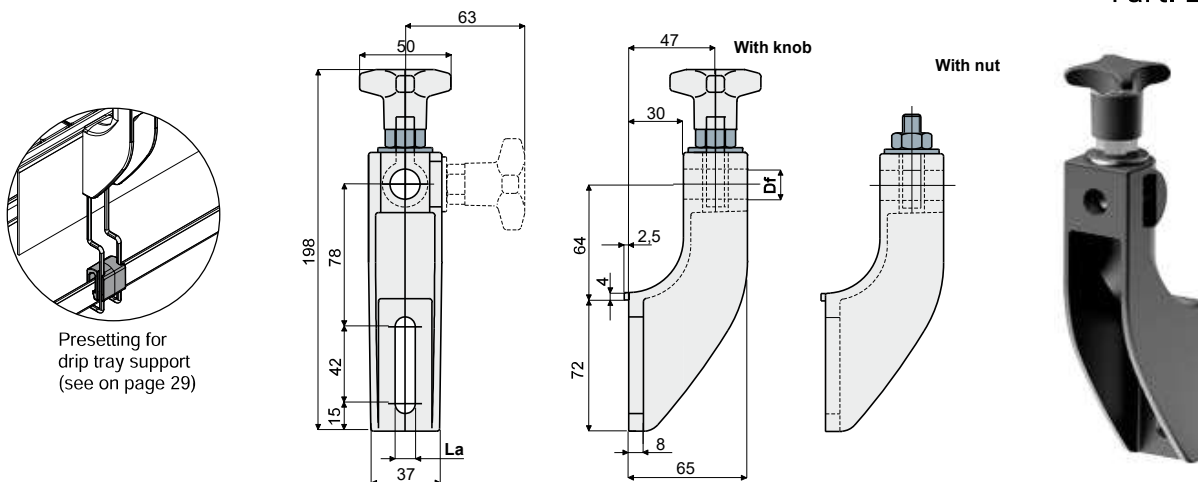

Df Bore for pin of (mm)	La (9 mm slot)	
	With knob Code	With nut Code
12	213 / 81176	213 / 82105
14	213 / 82102	213 / 82107
16	213 / 82104	213 / 82109

Df Bore for pin of (mm)	La (11 mm slot)	
	With knob Code	With nut Code
12	213 / 80652	213 / 80653
14	213 / 80654	213 / 80655
16	213 / 80656	213 / 80657

**MATERIALS:** Bracket and knob made of reinforced polyamide black colour; hexagonal insert made of nickel plated brass; eyebolt, nut and washer made of stainless steel AISI 304.

**FEATURES:** Max tightening torque 4 Kg-m.

**BOX QUANTITY:** 24 pieces.

**ON REQUEST:**

- Brackets: In reinforced polypropylene, other colours.
- Box quantity: According to your request.

## Guide rail bracket Part. 214 (with adjustable head)

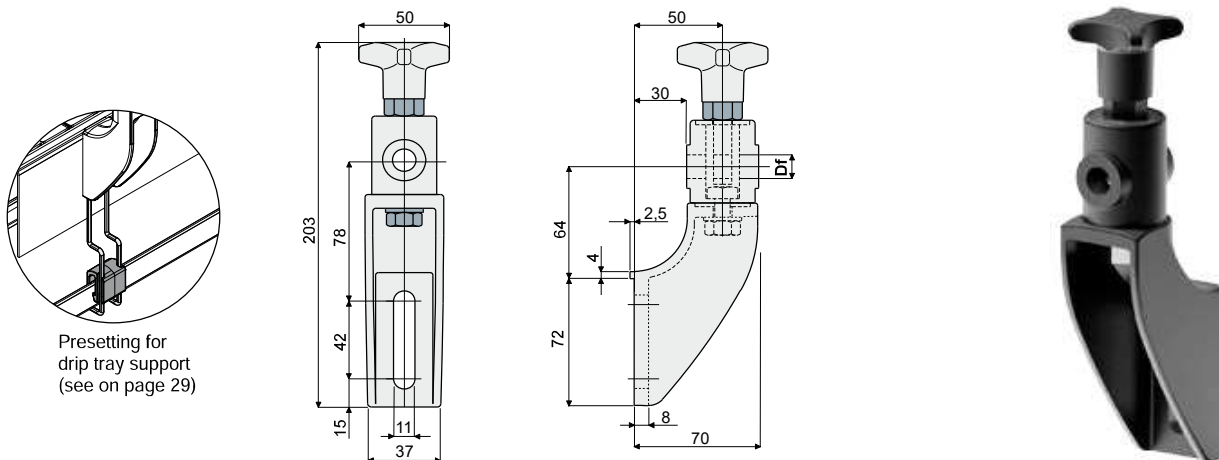

Df Bore for pin of (mm)	Code
12	214 / 80755
14	214 / 80756
16	214 / 80757

**MATERIALS:** Bracket and knob made of reinforced polyamide black colour; hexagonal insert made of nickel plated brass; eyebolt, screw, nut and washers made of stainless steel AISI 304.

**FEATURES:** Max tightening torque 4 Kg-m.

**BOX QUANTITY:** 24 pieces.

**ON REQUEST:**

- Brackets: In reinforced polypropylene, other colours.
- Box quantity: According to your request.

# Guide rail brackets

## Part. 215 Guide rail bracket (with adjustable head)

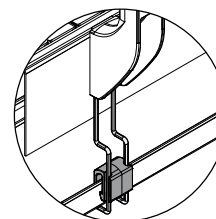
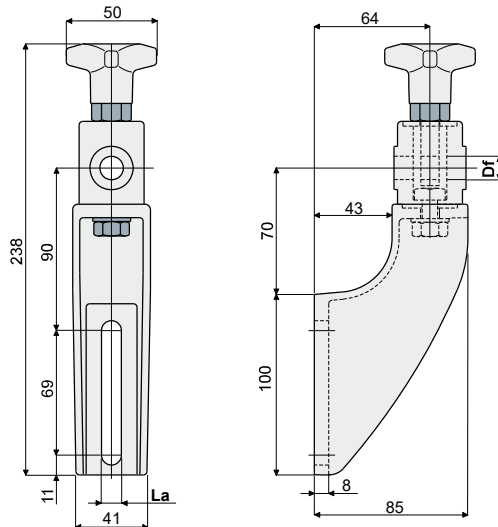

Presetting for drip tray support (see on page 29)

Df Bore for pin of (mm)	La (9 mm slot) Code	La (11 mm slot) Code
12	215 / 82106	215 / 80658
14	215 / 82108	215 / 80659
16	215 / 82110	215 / 80660

**MATERIALS:** Bracket and knob made of reinforced polyamide black colour; hexagonal insert made of nickel plated brass; eyebolt, screw, nut and washers made of stainless steel AISI 304.

**FEATURES:** Max tightening torque 4 Kg-m.

**BOX QUANTITY:** 24 pieces.

**ON REQUEST:**

- Brackets: In reinforced polypropylene, other colours.
- Box quantity: According to your request.

## Part. 243 Guide rail bracket (reinforced type with adjustable head)

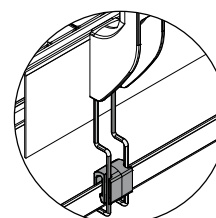
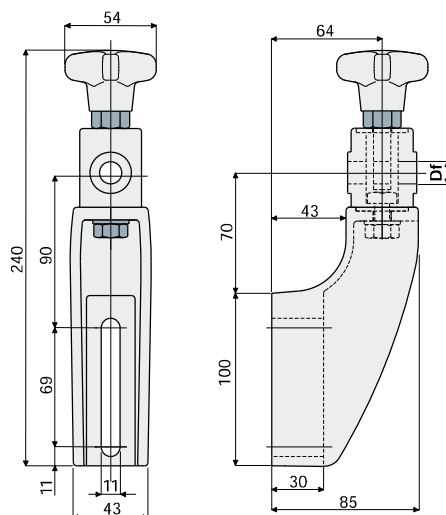

Presetting for drip tray support (see on page 29)

Df Bore for pin of (mm)	Code
12	243 / 81003
14	243 / 81004
16	243 / 81005

**MATERIALS:** Bracket and knob made of reinforced polyamide black colour; hexagonal insert made of nickel plated brass; eyebolt, screw, nut and washers made of stainless steel AISI 304.

**FEATURES:** To be used for heavy applications, suitable in conveyors with more ways, both in accumulation and curve. Max tightening torque 4 Kg-m.

**BOX QUANTITY:** 24 pieces.

**ON REQUEST:**

- Brackets: In reinforced polypropylene, other colours.
- Box quantity: According to your request.

# Guide rail brackets

## Guide rail bracket (with adjustable high type head) Part. 280

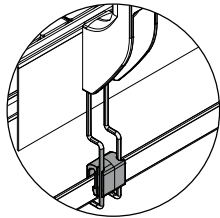

Presetting for drip tray support (see on page 29)

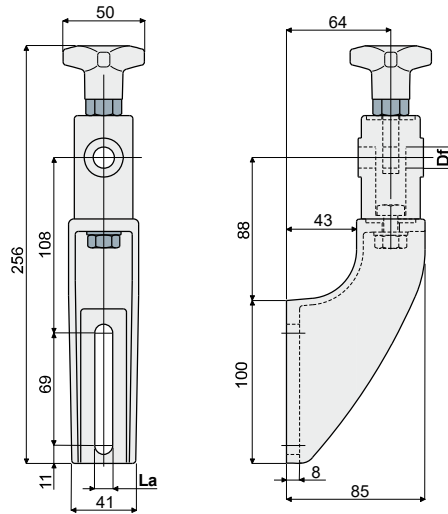

Df Bore for pin of (mm)	La (9 mm slot) Code	La (11 mm slot) Code
12	280 / 82150	280 / 82127
14	280 / 82151	280 / 82128
16	280 / 82152	280 / 82129

**MATERIALS:** Bracket and knob made of reinforced polyamide black colour; hexagonal insert made of nickel plated brass; eyebolt, screw, nut and washers made of stainless steel AISI 304.

**FEATURES:** Max tightening torque 4 Kg-m.

**BOX QUANTITY:** 24 pieces.

**ON REQUEST:**

- Brackets: In reinforced polypropylene, other colours.
- Box quantity: According to your request.

## Guide rail bracket (reinforced type with adjustable high type head) Part. 281

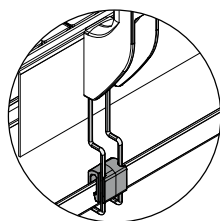

Presetting for drip tray support (see on page 29)

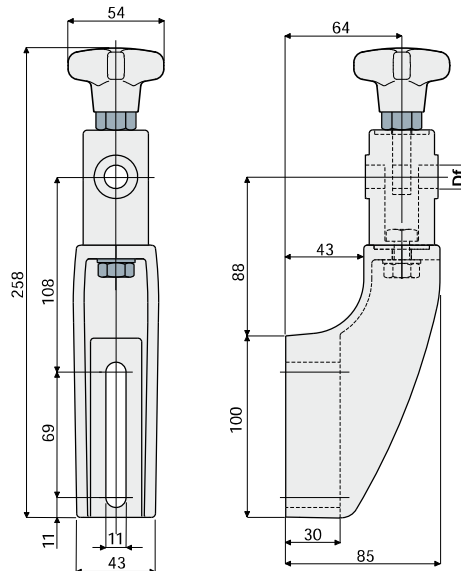

Df Bore for pin of (mm)	Code
12	281 / 82130
14	281 / 82131
16	281 / 82132

**MATERIALS:** Bracket and knob made of reinforced polyamide black colour; hexagonal insert made of nickel plated brass; eyebolt, screw, nut and washers made of stainless steel AISI 304.

**FEATURES:** To be used for heavy applications, suitable in conveyors with more ways, both in accumulation and curve. Max tightening torque 4 Kg-m.

**BOX QUANTITY:** 24 pieces.

**ON REQUEST:**

- Brackets: In reinforced polypropylene, other colours.
- Box quantity: According to your request.

# Guide rail brackets

## Guide rail bracket (with adjustable head)

Part. **279**

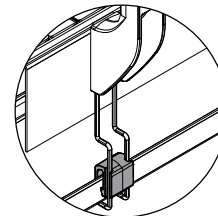
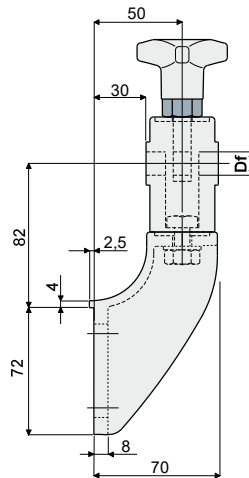
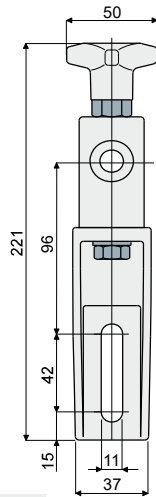

Presetting for drip tray support  
(see on page 29)

Df Bore for pin of (mm)	Code
12	279 / 82124
14	279 / 82125
16	279 / 82126

**MATERIALS:** Bracket and knob made of reinforced polyamide black colour; hexagonal insert made of nickel plated brass; eyebolt, screw, nut and washer made of stainless steel AISI 304.

**FEATURES:** Max tightening torque 4 Kg-m.

**BOX QUANTITY:** 24 pieces.

**ON REQUEST:**

- Brackets: In reinforced polypropylene, other colours.
- Box quantity: According to your request.

## Part. **216** Guide rail bracket (with metal adjustable head)

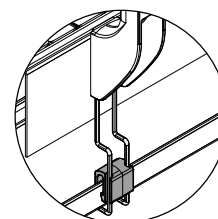
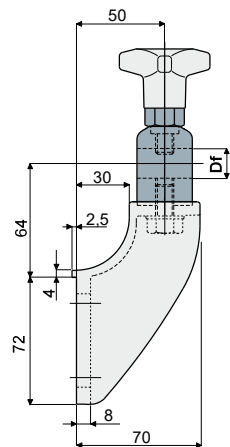
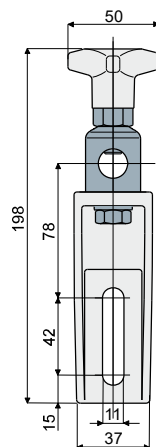

Presetting for drip tray support  
(see on page 29)

Df Bore for pin of (mm)	Code
14 - 16	216 / 80759

**MATERIALS:** Bracket and knob made out of reinforced polyamide black colour; head made out of stainless steel AISI 304; hexagonal insert made out of nickel plated brass; screw and washer made out of stainless steel AISI 304.

**FEATURES:** Possibility to use pins with diameter 14 and 16 mm. Max tightening torque 4 Kg-m.

**BOX QUANTITY:** 24 pieces.

**ON REQUEST:**

- Brackets: In reinforced polypropylene, other colours.
- Box quantity: According to your request.



# Guide rail brackets

## Guide rail bracket (with metal adjustable head) Part. 218

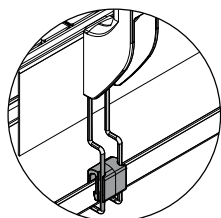

Presetting for drip tray support (see on page 29)

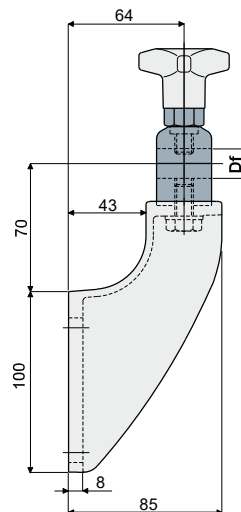
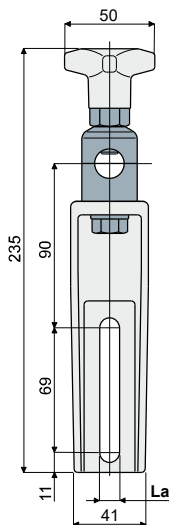

La (9 mm slot)		La (11 mm slot)	
Df	Code	Df	Code
Bore for pin of (mm)		Bore for pin of (mm)	
14 - 16	218 / 82113	14 - 16	218 / 80663

**MATERIALS:** Bracket and knob made out of reinforced polyamide black colour; head made out of stainless steel AISI 304; hexagonal insert made out of nickel plated brass; screw and washer made out of stainless steel AISI 304.

**FEATURES:** Possibility to use pins with diameter 14 and 16 mm. Max tightening torque 4 Kg-m.

**BOX QUANTITY:** 24 pieces.

**ON REQUEST:**

- Brackets: In reinforced polypropylene, other colours.
- Box quantity: According to your request.

## Guide rail bracket (reinforced type with metal adjustable head) Part. 244

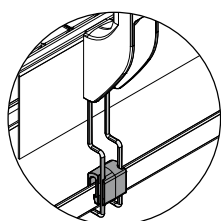

Presetting for drip tray support (see on page 29)

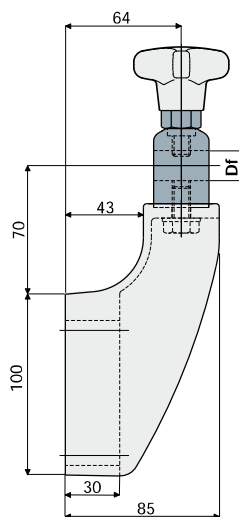
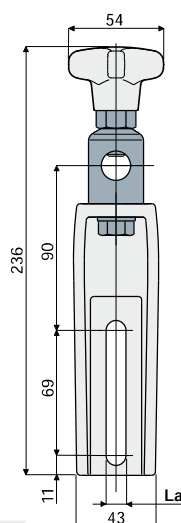

La (9 mm slot)		La (11 mm slot)	
Df	Code	Df	Code
Bore for pin of (mm)		Bore for pin of (mm)	
14 - 16	244 / 87159	14 - 16	244 / 81007

**MATERIALS:** Bracket and knob made out of reinforced polyamide black colour; head made out of stainless steel AISI 304; hexagonal insert made out of nickel plated brass; screw and washer made out of stainless steel AISI 304.

**FEATURES:** To be used for heavy applications, suitable in conveyors with more ways, both in accumulation and curve. Possibility to use pins with diameter 14 and 16 mm. Max tightening torque 4 Kg-m.

**BOX QUANTITY:** 24 pieces.

**ON REQUEST:**

- Brackets: In reinforced polypropylene, other colours.
- Box quantity: According to your request.

# Guide rail brackets

## Guide rail bracket (reinforced type with adjustable head)

Part. **488**

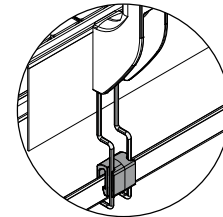
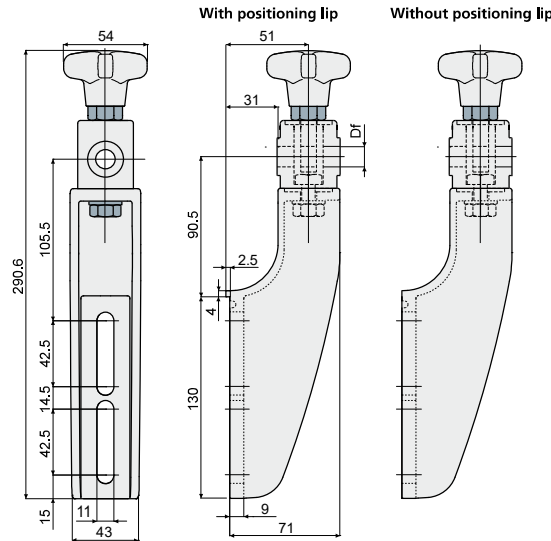

Presetting for drip tray support (see on page 29)

Df Bore for pin of (mm)	With positioning lip Code	Without positioning lip Code
12	488 / 86193	488 / 86194
14	488 / 86195	488 / 86196
16	488 / 86197	488 / 86198

**MATERIALS:** Bracket and knob made of reinforced polyamide black colour; hexagonal insert made of nickel plated brass; eyebolt, screw, nut and washers made of stainless steel AISI 304.

**FEATURES:** Max tightening torque 4 Kg-m.

**BOX QUANTITY:** 24 pieces.

**ON REQUEST:**

- Brackets: In reinforced polypropylene, other colours.
- Box quantity: According to your request.

## Part. **489** Guide rail bracket (reinforced type with adjustable high type head)

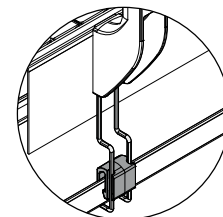
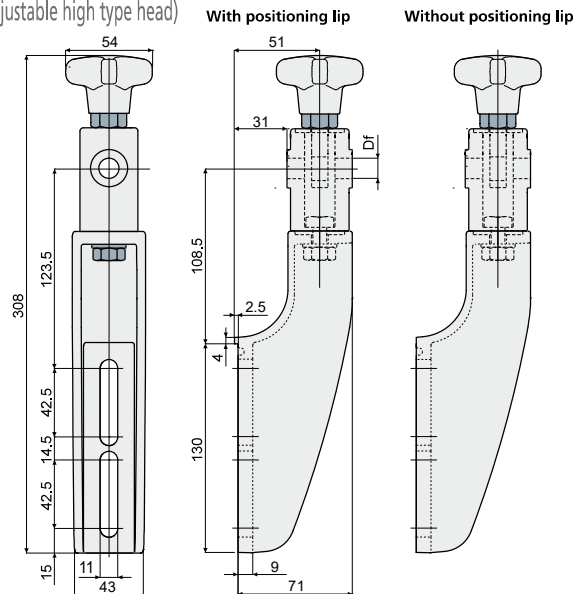

Presetting for drip tray support (see on page 29)

Df Bore for pin of (mm)	With positioning lip Code	Without positioning lip Code
12	489 / 86199	489 / 87000
14	489 / 87001	489 / 87002
16	489 / 87003	489 / 87004

**MATERIALS:** Bracket and knob made of reinforced polyamide black colour; hexagonal insert made of nickel plated brass; eyebolt, screw, nut and washers made of stainless steel AISI 304.

**FEATURES:** Max tightening torque 4 Kg-m.

**BOX QUANTITY:** 24 pieces.

**ON REQUEST:**

- Brackets: In reinforced polypropylene, other colours.
- Box quantity: According to your request.

# Guide rail brackets

## Guide rail bracket (reinforced type with metal adjustable head)

Part. **490**

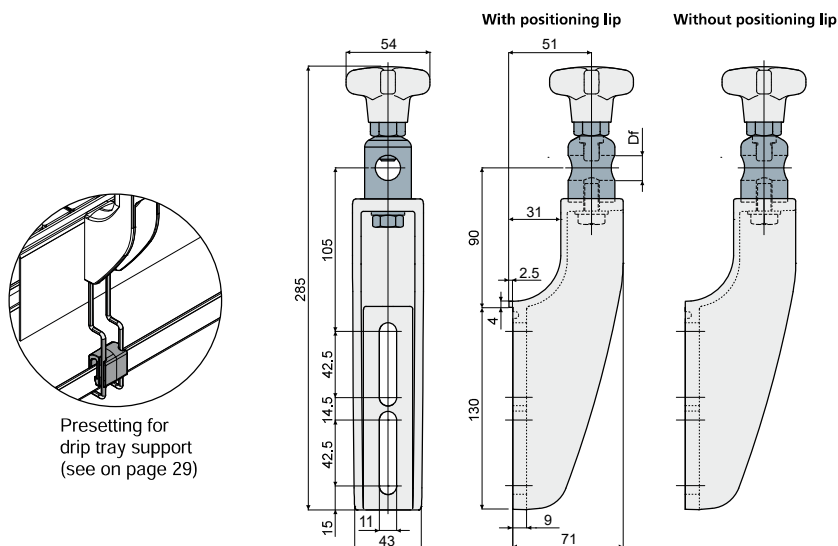

Df Bore for pin of (mm)	With positioning lip Code	Without positioning lip Code
16	490 / 87005	490 / 87006

**MATERIALS:** Bracket and knob made of reinforced polyamide black colour; head made out of stainless steel AISI 304; hexagonal insert made of nickel plated brass; eyebolt and washer made of stainless steel AISI 304.

**FEATURES:** Max tightening torque 4 Kg-m.

**BOX QUANTITY:** 24 pieces.

**ON REQUEST:**

- Brackets: In reinforced polypropylene, other colours.
- Box quantity: According to your request.

## Guide rail bracket (reinforced type with adjustable head)

Part. **491**

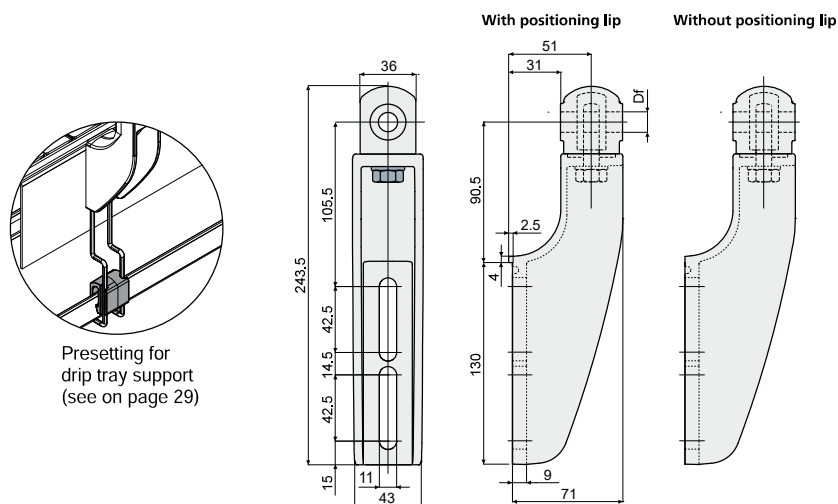

Df Bore for pin of (mm)	With positioning lip Code	Without positioning lip Code
12	491 / 87007	491 / 87008
14	491 / 87009	491 / 87010
16	491 / 87011	491 / 87012

**MATERIALS:** Bracket and knob made of reinforced polyamide black colour; hexagonal insert made of nickel plated brass; eyebolt, nut and washer made of stainless steel AISI 304.

**FEATURES:** Max tightening torque 4 Kg-m.

**BOX QUANTITY:** 24 pieces.

**ON REQUEST:**

- Brackets: In reinforced polypropylene, other colours.
- Box quantity: According to your request.

# Guide rail brackets

## Part. 255 Guide rail bracket (reinforced type with adjustable head)

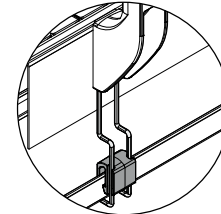
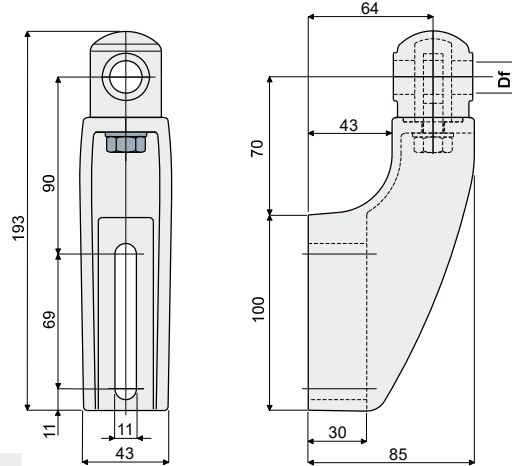

Presetting for drip tray support (see on page 29)

Df Bore for pin of (mm)	Code
12	255 / 81008
14	255 / 81009
16	255 / 81010

**MATERIALS:** Bracket and head made of reinforced polyamide black colour; eyebolt, nut and washer made of stainless steel AISI 304.

**FEATURES:** To be used for heavy applications, suitable in conveyors with more ways, both in accumulation and curve. Max tightening torque 4 Kg-m.

**BOX QUANTITY:** 24 pieces.

**ON REQUEST:**

- Brackets: In reinforced polypropylene, other colours.
- Box quantity: According to your request.

## Part. 219 Guide rail bracket (with adjustable head)

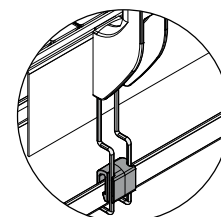
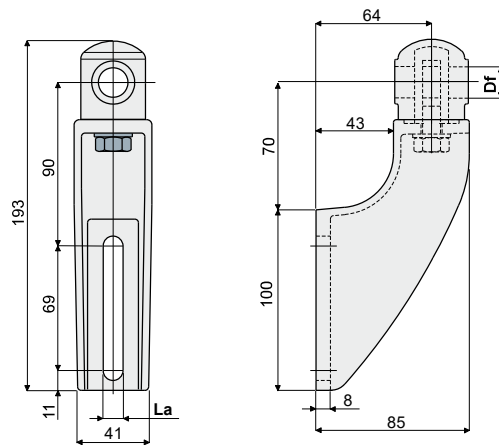

Presetting for drip tray support (see on page 29)

Df Bore for pin of (mm)	La (9 mm slot) Code	La (11 mm slot) Code
12	219 / 82114	219 / 80664
14	219 / 82115	219 / 80665
16	219 / 82116	219 / 80666

**MATERIALS:** Bracket and head made of reinforced polyamide black colour; eyebolt, nut and washer made of stainless steel AISI 304.

**FEATURES:** Max tightening torque 4 Kg-m.

**BOX QUANTITY:** 24 pieces.

**ON REQUEST:**

- Brackets: In reinforced polypropylene, other colours.
- Box quantity: According to your request.

# Guide rail brackets

## Guide rail bracket (with adjustable head)

Part. **217**

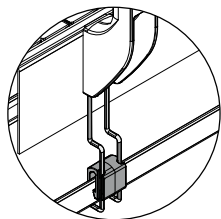

Presetting for drip tray support (see on page 29)

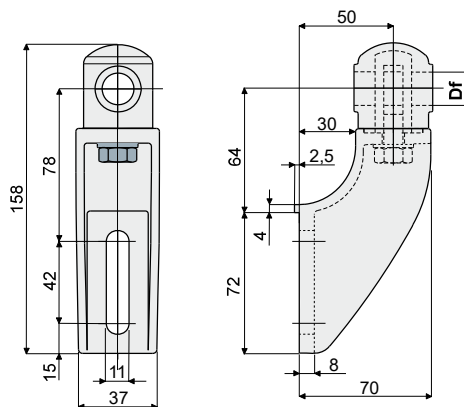

Df Bore for pin of (mm)	Code
12	217 / 80760
14	217 / 80761
16	217 / 80762

**MATERIALS:** Bracket and head made of reinforced polyamide black colour; eyebolt, nut and washer made of stainless steel AISI 304.

**FEATURES:** Max tightening torque 4 Kg-m.

**BOX QUANTITY:** 24 pieces.

**ON REQUEST:**

- Brackets: In reinforced polypropylene, other colours.
- Box quantity: According to your request.

## Guide rail bracket (for adjustable heads)

Part. **209**

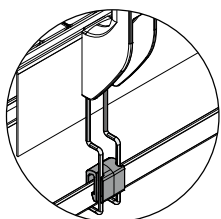

Presetting for drip tray support (see on page 29)

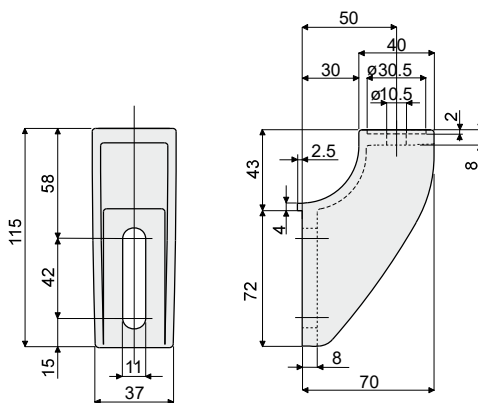

Code
209 / 80754

**MATERIALS:** Bracket made out of reinforced polyamide black colour.

**FEATURES:** To be used with heads Part.221, 222, 223 and 266.

**BOX QUANTITY:** 24 pieces.

**ON REQUEST:**

- Brackets: In reinforced polypropylene, other colours.
- Box quantity: According to your request.



# Guide rail brackets

Part. **220**

**Guide rail bracket**  
(for adjustable heads)

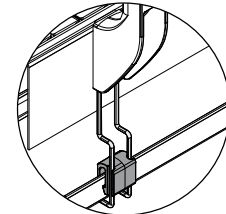
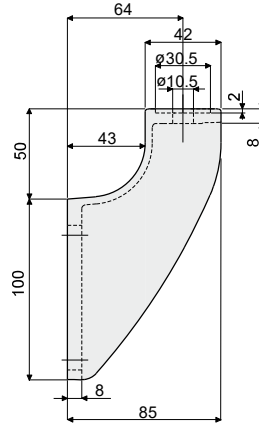
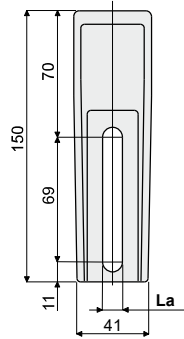

Presetting for drip tray support (see on page 29)

La (9 mm slot)	La (11 mm slot)
Code	Code
220 / 82111	220 / 80667

**MATERIALS:** Bracket made out of reinforced polyamide black colour.

**FEATURES:** To be used with heads Part.221, 222, 223 and 266.

**BOX QUANTITY:** 24 pieces.

**ON REQUEST:**

- Brackets: In reinforced polypropylene, other colours.
- Box quantity: According to your request.

Part. **242**

**Guide rail bracket**  
(reinforced type for adjustable head)

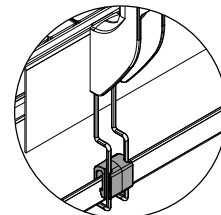
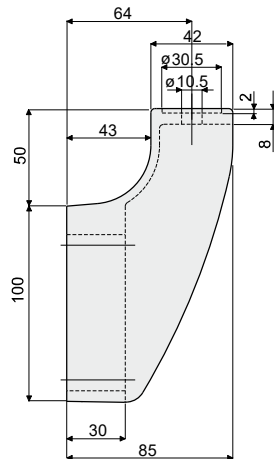
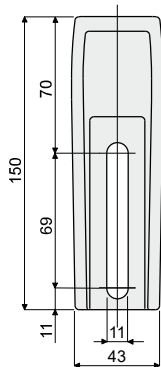

Presetting for drip tray support (see on page 29)

Code
242 / 81002

**MATERIALS:** Bracket made of reinforced polyamide black colour.

**FEATURES:** To be used with heads Part.221, 222, 223 and 266 for heavy applications. Suitable in conveyors with more ways, both in accumulation and curve.

**BOX QUANTITY:** 24 pieces.

**ON REQUEST:**

- Brackets: In reinforced polypropylene, other colours.
- Box quantity: According to your request.

# Guide rail brackets

## Guide rail bracket

(reinforced type for adjustable heads)

Part. **486**

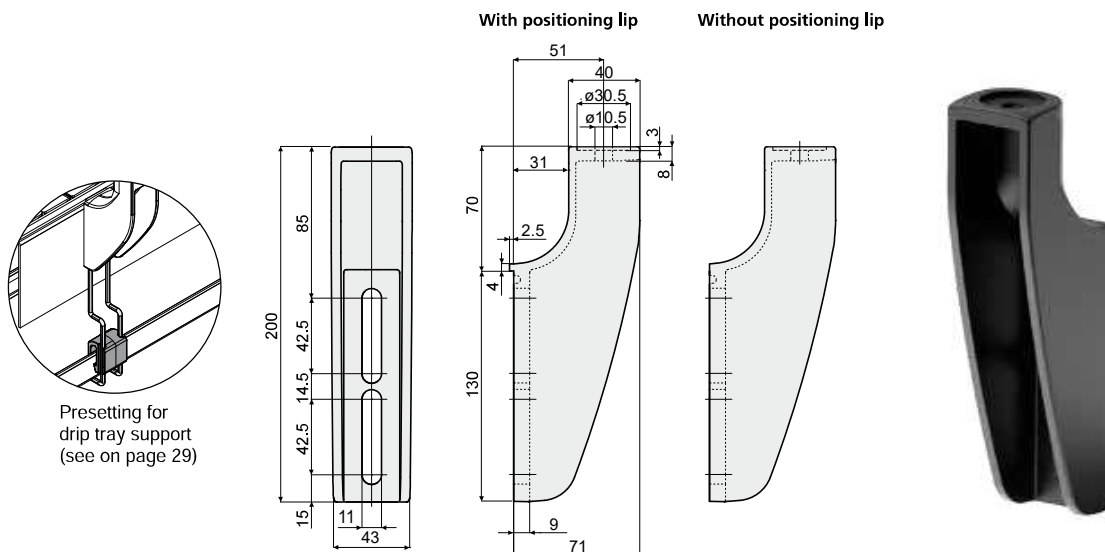

With positioning lip	Without positioning lip
Code	Code
486 / 86189	486 / 86190

**MATERIALS:** Bracket made out of reinforced polyamide black colour.

**FEATURES:** To be used with heads Part.221, 222, 223 and 266.

**BOX QUANTITY:** 24 pieces.

**ON REQUEST:**

- Brackets: In reinforced polypropylene, other colours.
- Box quantity: According to your request.

## Spacer for bracket

Part. **487**

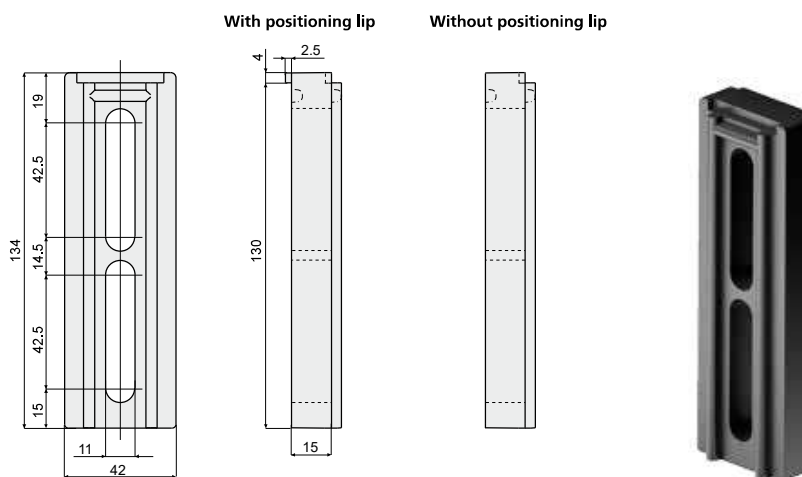

With positioning lip	Without positioning lip
Code	Code
487 / 86191	487 / 86192

**MATERIALS:** Spacer made of reinforced polyamide black colour.

**FEATURES:** Accessory to be used with brackets Part.486, 488, 489, 490, 491.

**BOX QUANTITY:** 24 pieces.

**ON REQUEST:**

- Spacers: In reinforced polypropylene, other colours.
- Box quantity: According to your request.

# Guide rail brackets

## Part. 224 Spacer for bracket

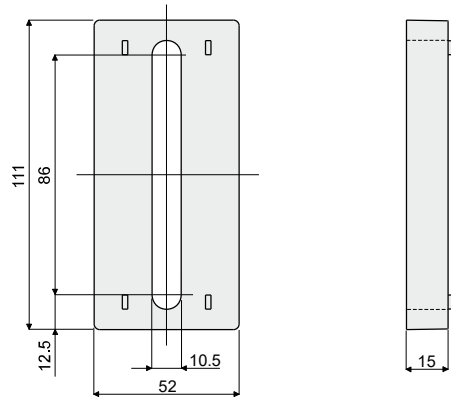
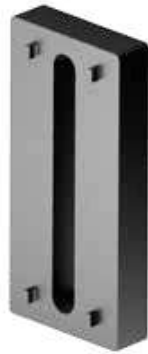

Code

224 / 80676

**MATERIALS:** Spacer made of reinforced polyamide black colour.

**FEATURES:** Accessory to be used with brackets Part.215, 218, 219, 220, 242, 243, 244, 255, 280, 281.

**BOX QUANTITY:** 24 pieces.

**ON REQUEST:**

- Spacers: In reinforced polypropylene, other colours.
- Box quantity: According to your request.

## Part. 225 Spacer for bracket

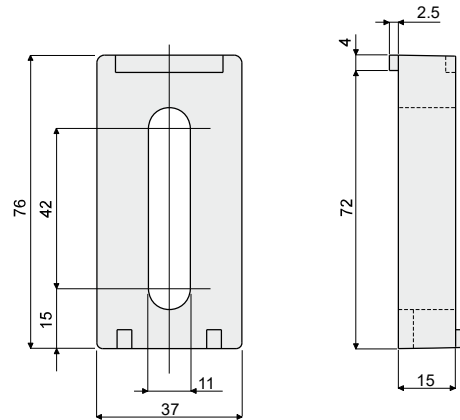

Code

225 / 80677

**MATERIALS:** Spacer made of reinforced polyamide black colour.

**FEATURES:** Accessory to be used with brackets Part.213, 214, 216, 217, 209, 279.

**BOX QUANTITY:** 24 pieces.

**ON REQUEST:**

- Spacers: In reinforced polypropylene, other colours.
- Box quantity: According to your request.

## Part. 530 Spacer for bracket

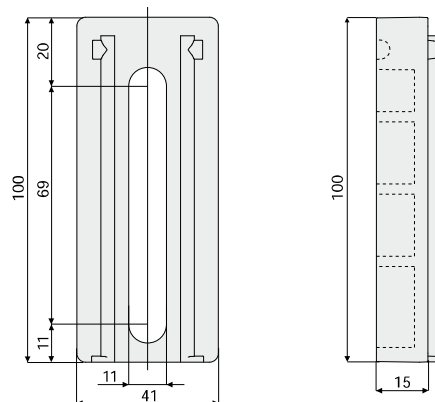

Code

530 / 87752

**MATERIALS:** Spacer made of reinforced polyamide black colour.

**FEATURES:** Accessory to be used with brackets Part.215, 218, 219, 220, 242, 243, 244, 255, 280, 281.

**BOX QUANTITY:** 24 pieces.

**ON REQUEST:**

- Spacers: In reinforced polypropylene, other colours.
- Box quantity: According to your request.

# Guide rail brackets

## Drip tray support

## Part. 236

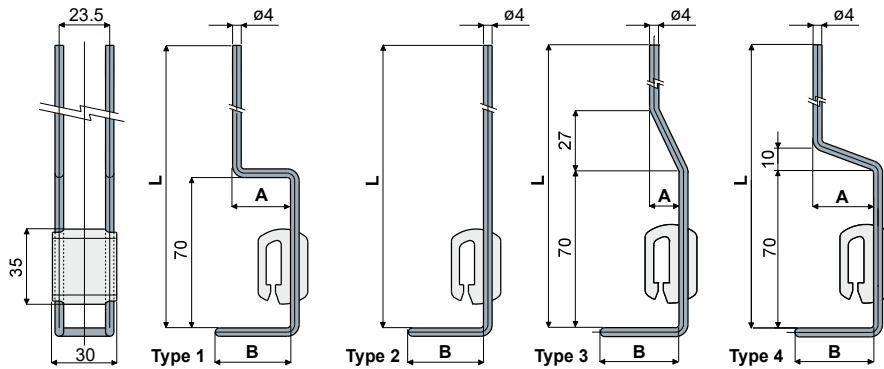

L (mm)	B (mm)	A (mm)	Type 1 Code
180	35	27	236 / 80779
180	35	17	236 / 81012
230	35	27	236 / 82683
310	35	18	236 / 88679 <b>NEW</b>

L (mm)	B (mm)	Type 2 Code
200	35	236 / 80780
246	35	236 / 81013

L (mm)	B (mm)	A (mm)	Type 3 Code
250	35	13	236 / 82640

L (mm)	B (mm)	A (mm)	Type 4 Code
280	35	27	236 / 82949



**MATERIALS:** Support elements made of stainless steel AISI 304; body of coupling made of reinforced polyamide black colour.

**FEATURES:** To be used to support drip trays.

**BOX QUANTITY:** 24 pieces.

**ON REQUEST:**

- Drip tray supports: Supplied in different shapes and sizes.
- Box quantity: According to your request.

## Mounting plate (for drip tray support)

## Part. 235

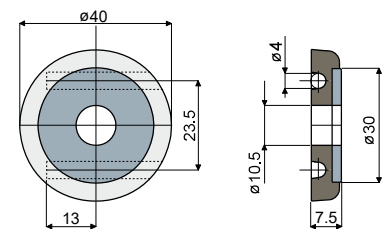
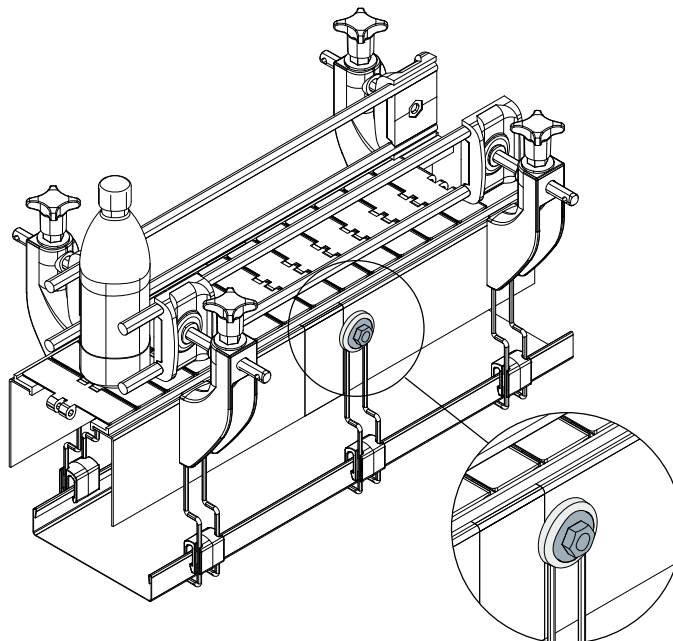

Code
235 / 80778

### Example of application

**MATERIALS:** Plate made of reinforced polyamide black colour; washer made of stainless steel AISI 304.

**FEATURES:** For application on conveyor side to fasten drip tray support.

**BOX QUANTITY:** 24 pieces.

**ON REQUEST:**

- Box quantity: According to your request.

# Guide rail brackets

Part. **387** **Bracket 90°**  
(70 mm x 70 mm)

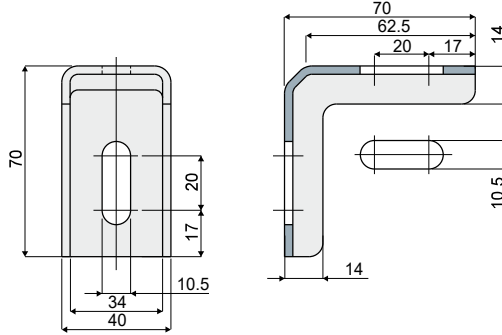

Code

387 / 84128

MATERIALS: Bracket in stainless steel AISI 304.

BOX QUANTITY: 24 pieces.

ON REQUEST:

- Box quantity: According to your request.

Part. **392** **Bracket 90°**  
(70 mm x 140 mm)

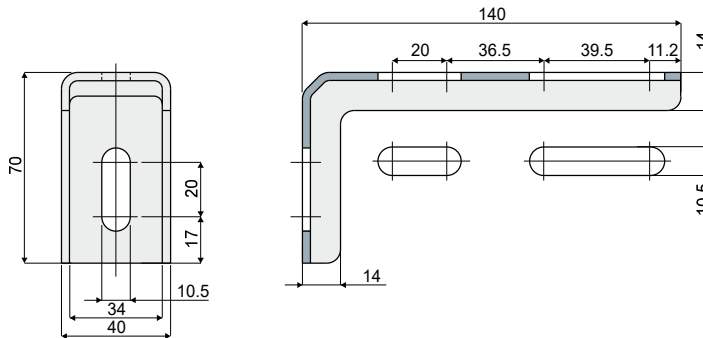

Code

392 / 84130

MATERIALS: Bracket in stainless steel AISI 304.

BOX QUANTITY: 24 pieces.

ON REQUEST:

- Box quantity: According to your request.

Part. **436** **Bracket 90°**  
(83 mm x 98 mm)

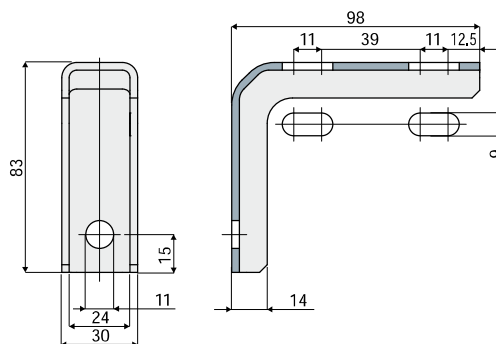

Code

436 / 85215

MATERIALS: Bracket in stainless steel AISI 304.

BOX QUANTITY: 24 pieces.

ON REQUEST:

- Box quantity: According to your request.



# Guide rail brackets

Example of application

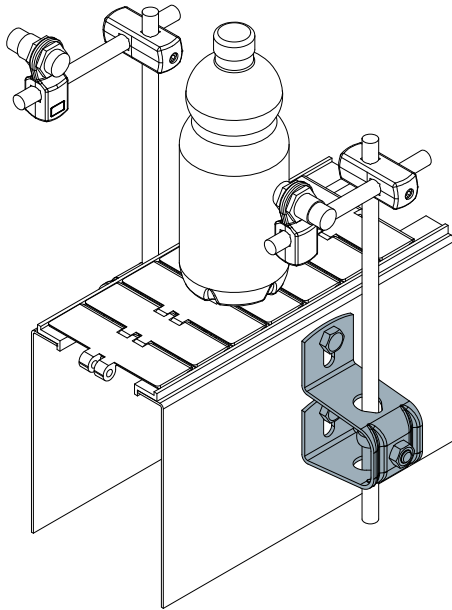

**Guide rail bracket**  
(compact version)

Part. **408**

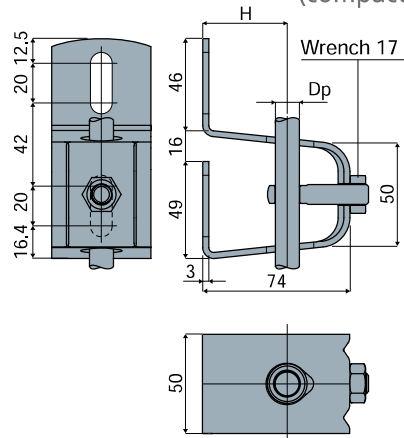

Dp Pin diameter (mm)	H (mm)	Code
12	49	408 / 84337
14	47	408 / 84338
16	46	408 / 84339
20	43	408 / 88698

**NEW**

**MATERIALS:** Bracket, eyebolt and nut made of stainless steel AISI 304.

**FEATURES:** Supplied complete with bolts and nuts.

**BOX QUANTITY:** 8 pieces.

**ON REQUEST:**

- Box quantity: According to your request.
- Assembly of: Eyebolts, nuts.

Example of application

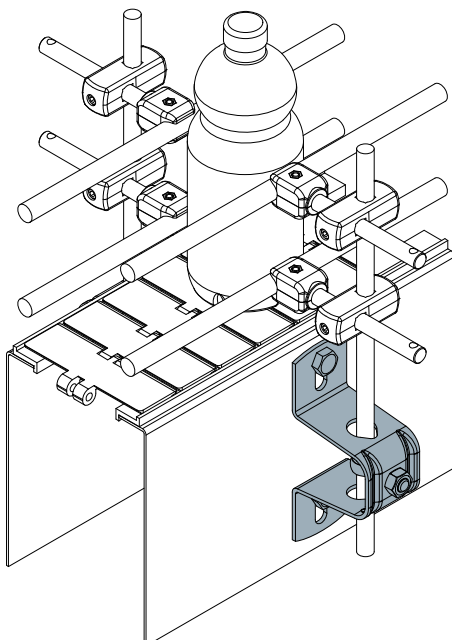

**Guide rail bracket**  
(standard version)

Part. **408**

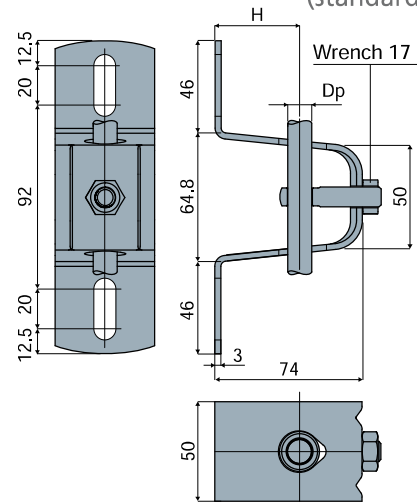

Dp Pin diameter (mm)	H (mm)	Code
12	49	408 / 84334
14	47	408 / 84335
16	46	408 / 84336
20	43	408 / 88700

**NEW**

**MATERIALS:** Bracket, eyebolt and nut made of stainless steel AISI 304.

**FEATURES:** Supplied complete with bolts and nuts.

**BOX QUANTITY:** 8 pieces.

**ON REQUEST:**

- Box quantity: According to your request.
- Assembly of: Eyebolts, nuts.

# Guide rail brackets

## Part. 442 Guide rail bracket

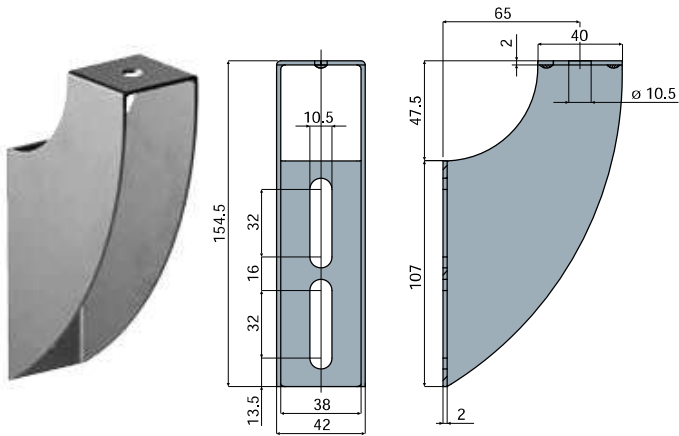

Code  
442 / 85242

MATERIALS: Bracket made of stainless steel AISI 304.

BOX QUANTITY: 24 pieces.

ON REQUEST:

- Box quantity: According to your request.

### Example of application

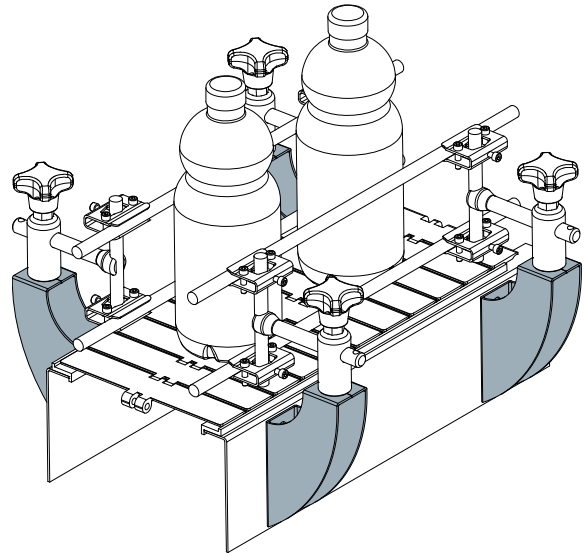

## Part. 441 Guide rail bracket

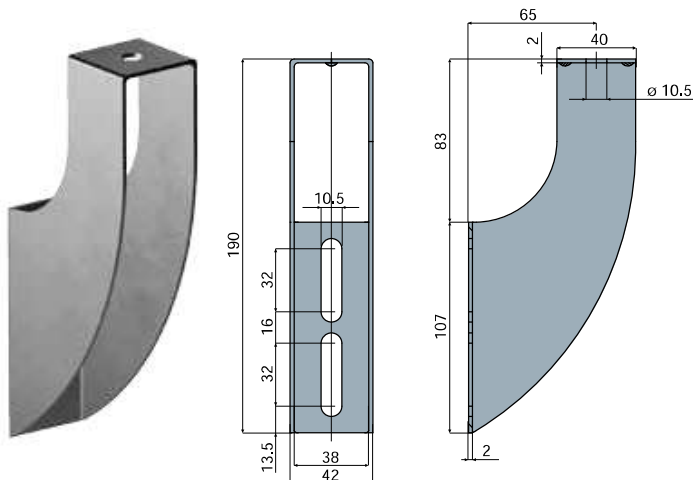

Code  
441 / 85241

MATERIALS: Bracket made of stainless steel AISI 304.

BOX QUANTITY: 24 pieces.

ON REQUEST:

- Box quantity: According to your request.

### Example of application

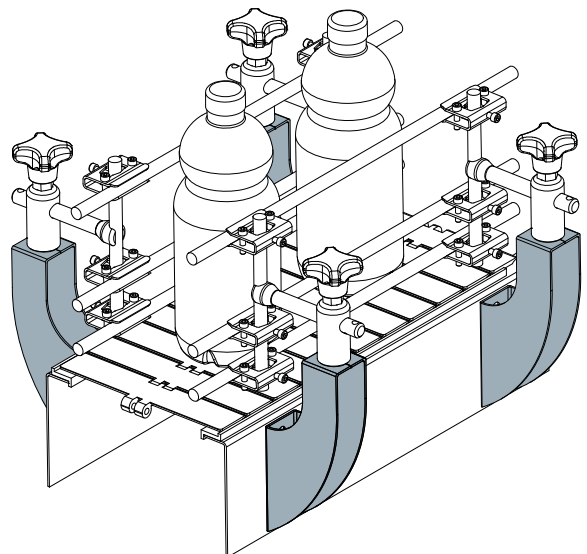

# Tightening eyebolts

Example of application

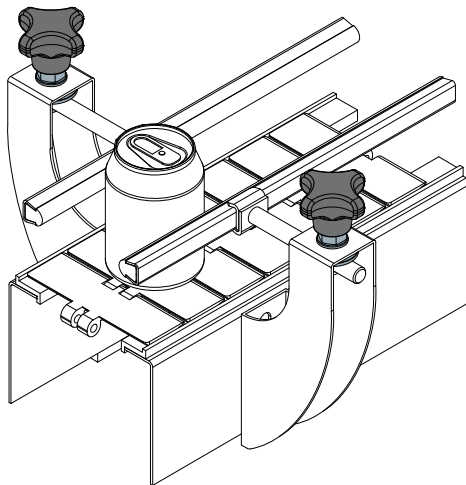

**Tightening eyebolt**  
(with knob)

Part. **406**

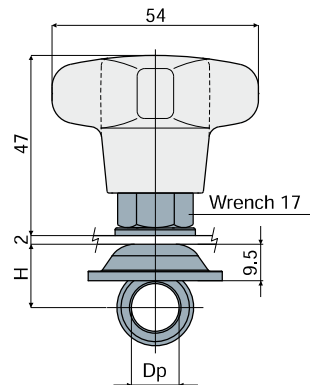

Dp Pin diameter (mm)	H (mm)	Code
12	15,5	406 / 84328
14	16,5	406 / 84329
16	17,5	406 / 84330

**MATERIALS:** Eyebolt and washers made of stainless steel AISI 304, threaded bushing in nickel plated brass; knob in reinforced polyamide black colour.

**FEATURES:** Supplied complete with bolts and nuts.

**BOX QUANTITY:** 24 pieces.

**ON REQUEST:**

- Assembly of: Eyebolts, washers and nuts.
- Box quantity: According to your request.

Example of application

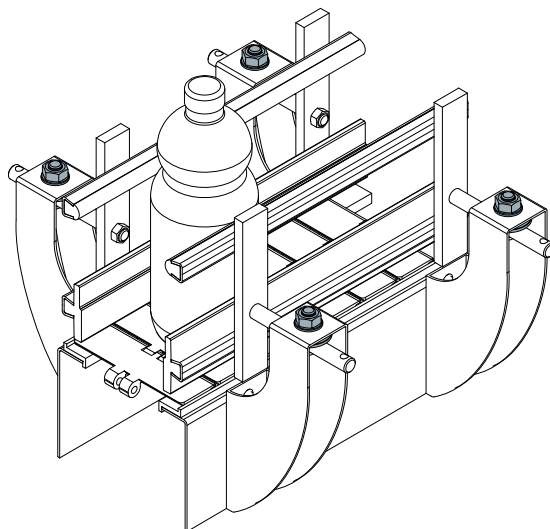

**Tightening eyebolt**  
(with nut)

Part. **407**

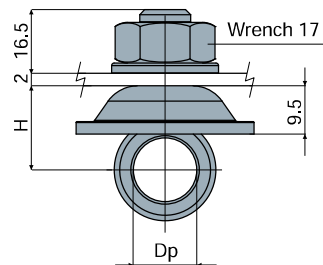

Dp Pin diameter (mm)	H (mm)	Code
12	15,5	407 / 84331
14	16,5	407 / 84332
16	17,5	407 / 84333

**MATERIALS:** Eyebolt, washers and nuts made of stainless steel AISI 304.

**FEATURES:** Supplied complete with bolts and nuts.

**BOX QUANTITY:** 24 pieces.

**ON REQUEST:**

- Assembly of: Eyebolts, washers and nuts.
- Box quantity: According to your request.

# Heads for brackets

## Part. 222 Head for bracket



Df	Bore for pin of (mm)	Code
12	12	222 / 80671
14	14	222 / 80672
16	16	222 / 80673

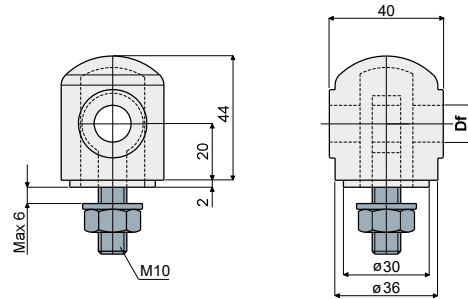

**MATERIALS:** Head made of reinforced polyamide black colour; eyebolt, nut and washer made of stainless steel AISI 304.

**FEATURES:** To be used with bracket Part.209, 220, 242, 441, 442, 486. Max tightening torque 4 Kg-m.

**BOX QUANTITY:** 24 pieces.

**ON REQUEST:**

- Heads: In reinforced polypropylene, other colours.
- Box quantity: According to your request.

## Part. 221 Head for bracket



Df	Bore for pin of (mm)	Code
12	12	221 / 80668
14	14	221 / 80669
16	16	221 / 80670

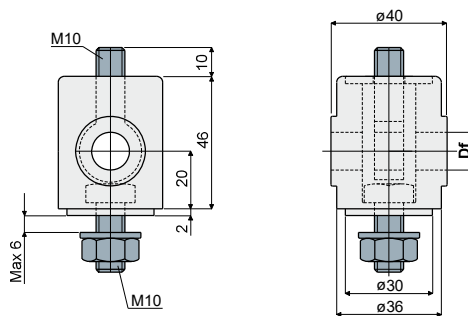

**MATERIALS:** Head made of reinforced polyamide black colour; eyebolt, screw, nut and washers made of stainless steel AISI 304.

**FEATURES:** To be used with bracket Part.209, 220, 242, 441, 442, 486. Max tightening torque 4 Kg-m.

**BOX QUANTITY:** 24 pieces.

**ON REQUEST:**

- Heads: In reinforced polypropylene, other colours.
- Box quantity: According to your request.

## Part. 266 Head for bracket (high type)



Df	Bore for pin of (mm)	Code
12	12	266 / 82035
14	14	266 / 82036
16	16	266 / 82037

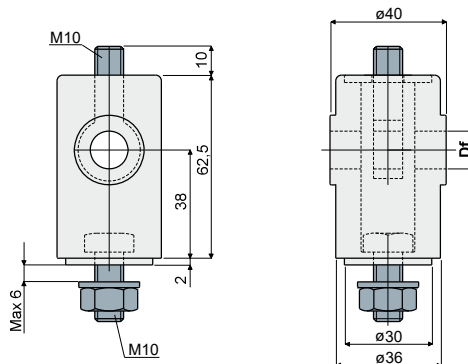

**MATERIALS:** Head made of reinforced polyamide black colour; eyebolt, nuts and washer made of stainless steel AISI 304.

**FEATURES:** To be used with bracket Part.209, 220, 242, 441, 442, 486. Max tightening torque 4 Kg-m.

**BOX QUANTITY:** 24 pieces.

**ON REQUEST:**

- Heads: Made of reinforced polypropylene, other colours.
- Box quantity: According to your request.

# Heads for brackets

## Head for bracket (metal)

Part. **223**

M	Df		H1	H2	Code
	Bore for pin of				
	(mm)	(inches)	(mm)	(mm)	
M8x16	14 - 16	-	23	43	223 / 84544
M10x16	14 - 16	-	23	43	223 / 84226
M10x20	12,7	1/2"	23	43	223 / 84543
M10x20	14 - 16	-	23	43	223 / 80675
	14 - 16	-	40	60	223 / 84542
	14 - 16	-	60	80	223 / 83640

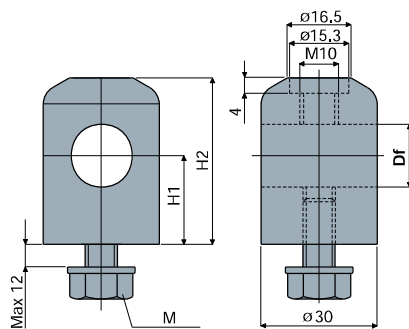

**MATERIALS:** Head made out of stainless steel AISI 304; screw and washer made out of stainless steel AISI 304.

**FEATURES:** To be used with Part.209, 220, 242, 441, 442, 486. Max tightening torque 4 Kg-m. Possibility to use pins with diameter 12.7, 14, 16 mm and 1/2".

**BOX QUANTITY:** 24 pieces.

**ON REQUEST:**

- Heads: In different lengths.
- Box quantity: According to your request.

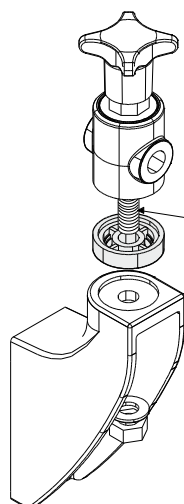

Example of application

N.B.: To use the spacer, it is necessary to change the standard screw with a longer one.

Code
256 / 81011

**MATERIALS:** Spacer made of reinforced polyamide black colour.

**FEATURES:** Accessory to be used on brackets Part.214, 215, 216, 209, 220, 242, 218, 243, 244, 279, 280, 281, 486, 488, 489, 490 to increase heads height.

**BOX QUANTITY:** 24 pieces.

**ON REQUEST:**

- Spacers: In reinforced polypropylene, other colours.
- Box quantity: According to your request.

## Spacer for heads

Part. **256**

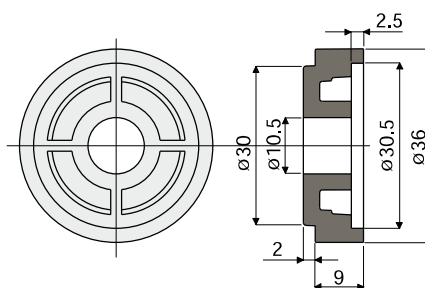

## Eyebolt Part. **526**

M	Df		D	H	I	A	S	Code
	Bore diameter							
	(mm)							
M10x20	13		22	21	39	49	9	526 / 87380
	14,5		22	21	39	49	9	526 / 87381
	16,5		23,5	28	40	52	9,5	526 / 87382
	20,5		27	26	40	53,5	7	526 / 88704 <b>NEW</b>

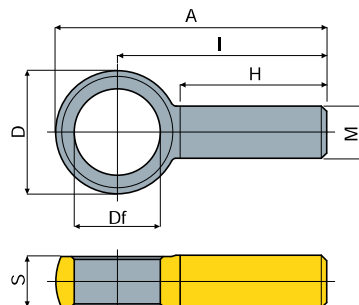

**MATERIALS:** Eyebolt in stainless steel AISI 304.

**FEATURES:** To be used with Part.213, 214, 215, 217, 219, 221, 222, 227, 243, 247, 255, 266, 279, 280, 281, 312, 406, 407, 408, 488, 489, 491. Possibility to use pins with diameter 12.7, 14, 16, 20 mm and 1/2".

**BOX QUANTITY:** 24 pieces.

**ON REQUEST:**

- Box quantity: According to your request.



# Knobs and handles

## Part. 226 Knob for bracket

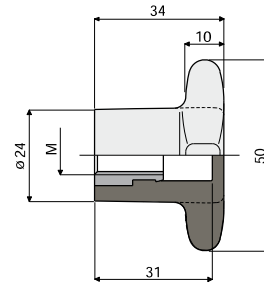
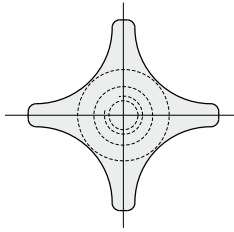

M	Code
M8	226 / 81147
M10	226 / 80678
M12	226 / 81148

**MATERIALS:** Knob made of reinforced polyamide black colour; threaded bushing made of nickel plated brass.

**FEATURES:** Accessory to be used with heads Part.221 and 266.

**BOX QUANTITY:** 24 pieces.

**ON REQUEST:**

- Knobs: In reinforced polypropylene, other colours.
- Box quantity: According to your request.

## Part. 227 Knob for bracket

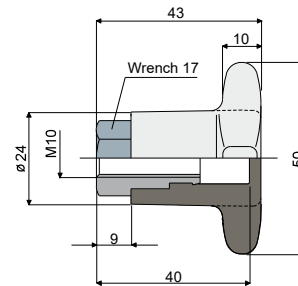
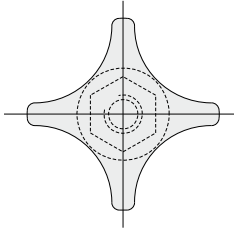

Code
227 / 80679

**MATERIALS:** Knob made of reinforced polyamide black colour; threaded bushing made of nickel plated brass.

**FEATURES:** Accessory to be used with heads Part.221 and 266.

**BOX QUANTITY:** 24 pieces.

**ON REQUEST:**

- Knobs: In reinforced polypropylene, other colours.
- Box quantity: According to your request.

## Part. 228 Knob for bracket

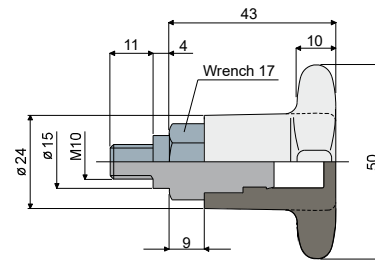
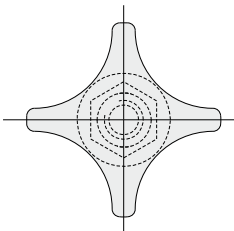

Code
228 / 80680

**MATERIALS:** Knob made of reinforced polyamide black colour; threaded bushing made of nickel plated brass.

**FEATURES:** Accessory to be used with head Part.223.

**BOX QUANTITY:** 24 pieces.

**ON REQUEST:**

- Knobs: In reinforced polypropylene, other colours.
- Box quantity: According to your request.

# Knobs and handles

## Knob for bracket (reinforced type) Part. 246

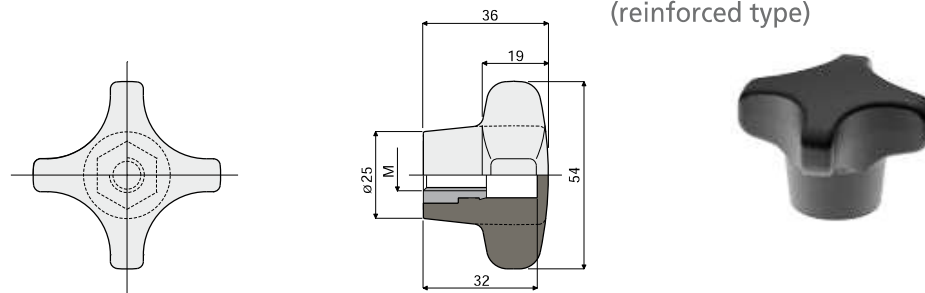

M	Code
M8	246 / 84473
M10	246 / 81135
M12	246 / 84870

**MATERIALS:** Knob made of reinforced polyamide black colour; threaded bushing is made of nickel plated brass.

**FEATURES:** Accessory to be applied to our heads Part.221 and Part.266.

**BOX QUANTITY:** 24 pieces.

**ON REQUEST:**

- Knobs: In reinforced polypropylene, other colours.
- Box quantity: According to your request.

## Knob for bracket (reinforced type) Part. 247

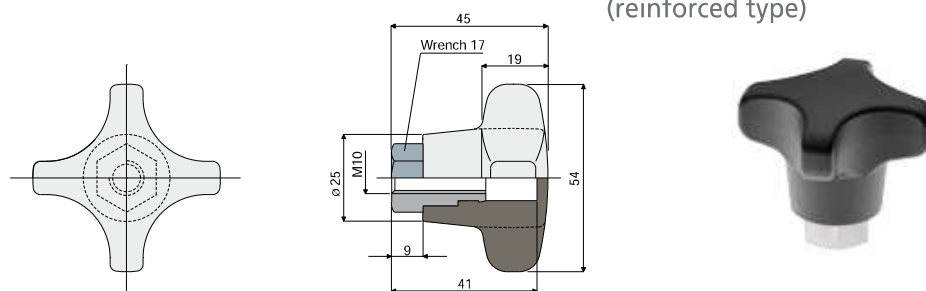

Code
247 / 81137

**MATERIALS:** Knob made of reinforced polyamide black colour; threaded bushing made of nickel plated brass.

**FEATURES:** Accessory to be applied to our heads Part.221 and Part.266.

**BOX QUANTITY:** 24 pieces.

**ON REQUEST:**

- Knobs: In reinforced polypropylene, other colours.
- Box quantity: According to your request.

## Knob for bracket (reinforced type) Part. 248

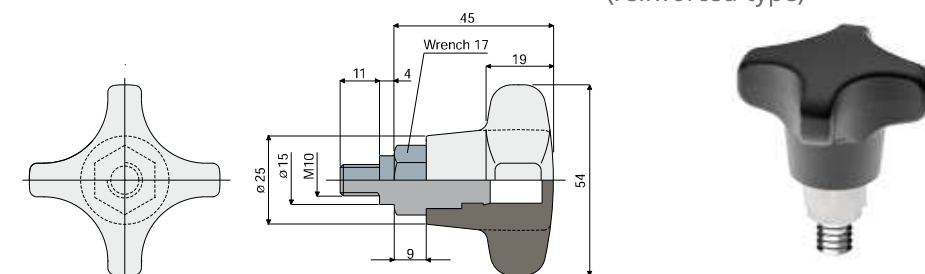

Code
248 / 81139

**MATERIALS:** Knob made of reinforced polyamide black colour; threaded insert made of nickel plated brass.

**FEATURES:** Accessory to be applied to our head Part.223.

**BOX QUANTITY:** 24 pieces.

**ON REQUEST:**

- Knobs: In reinforced polypropylene, other colours.
- Box quantity: According to your request.

# Knobs and handles

## Part. 313 Knob for bracket (short type)

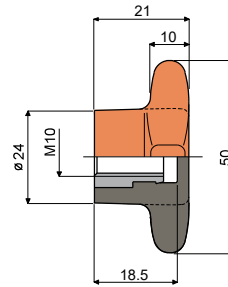
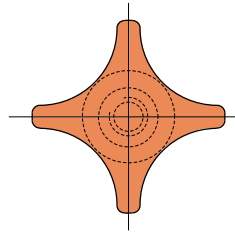

Code

313 / 82848

**MATERIALS:** Knob made of reinforced polyamide orange colour; threaded bushing made of nickel plated brass.

**FEATURES:** Accessory to be used with heads Part.221 and 266.

**BOX QUANTITY:** 24 pieces.

**ON REQUEST:**

- Knobs: In reinforced polypropylene, other colours.
- Box quantity: According to your request.

## Part. 314 Knob for bracket (short type)

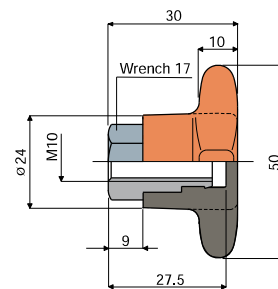
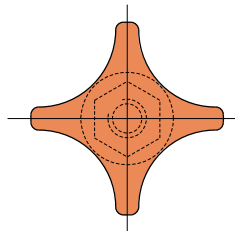

Code

314 / 82849

**MATERIALS:** Knob made of reinforced polyamide orange colour; threaded bushing made of nickel plated brass.

**FEATURES:** Accessory to be used with heads Part.221 and 266.

**BOX QUANTITY:** 24 pieces.

**ON REQUEST:**

- Knobs: In reinforced polypropylene, other colours.
- Box quantity: According to your request.

## Part. 315 Knob for bracket (short type)

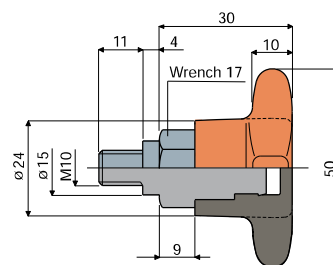
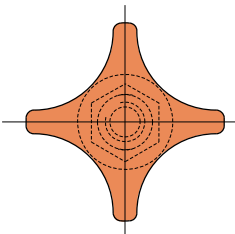

Code

315 / 82850

**MATERIALS:** Knob made of reinforced polyamide orange colour; threaded bushing made of nickel plated brass.

**FEATURES:** Accessory to be used with head Part.223.

**BOX QUANTITY:** 24 pieces.

**ON REQUEST:**

- Knobs: In reinforced polypropylene, other colours.
- Box quantity: According to your request.

# Knobs and handles

**Round handle** Part. **386**  
( $\varnothing$  44 mm)

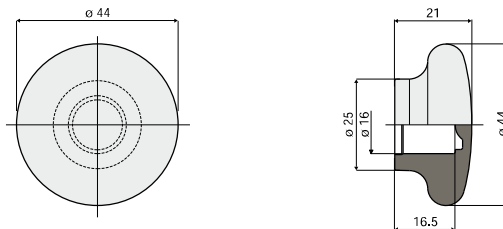

Code  
**386 / 84124**

**MATERIALS:** Handle in reinforced polypropylene, orange colour.  
**FEATURES:** To be used as protection for the pins edges; can be used with pin Part.301 ( $D_p = 16$  mm.).  
**BOX QUANTITY:** 24 pieces.

**ON REQUEST:**

- Handles: in reinforced polypropylene, different colours.
- Box quantity: According to your request.

**Round handle** Part. **334**  
( $\varnothing$  44 mm)

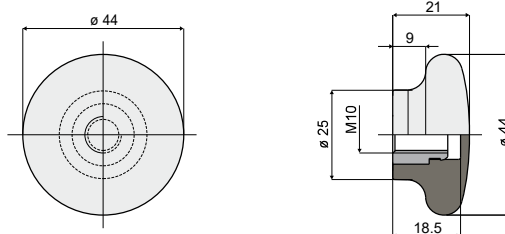

Code  
**334 / 83116**

**MATERIALS:** Handle made of reinforced polyamide black colour; threaded bushing made of nickel plated brass.  
**FEATURES:** Accessory to be used with heads Part.221 and 266.  
**BOX QUANTITY:** 24 pieces.

**ON REQUEST:**

- Handles: In reinforced polypropylene, other colours.
- Box quantity: According to your request.

**Round handle** Part. **337**  
( $\varnothing$  44 mm)

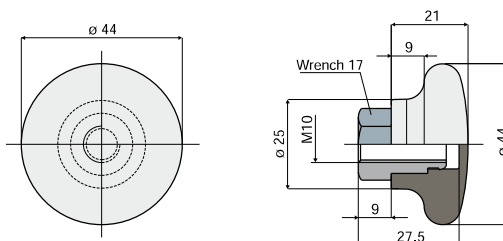

Code  
**337 / 83302**

**MATERIALS:** Handle made of reinforced polyamide black colour; threaded bushing made of nickel plated brass.  
**FEATURES:** Accessory to be used with heads Part.221 and 266.  
**BOX QUANTITY:** 24 pieces.

**ON REQUEST:**

- Handles: In reinforced polypropylene, other colours.
- Box quantity: According to your request.

**Round handle** Part. **338**  
( $\varnothing$  44 mm)

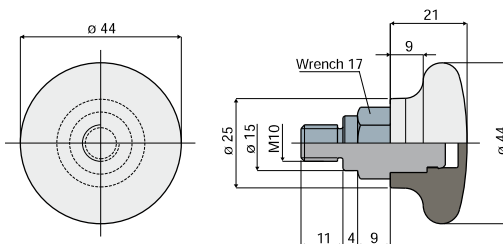

Code  
**338 / 83303**

**MATERIALS:** Handle made of reinforced polyamide black colour; threaded bushing made of nickel plated brass.  
**FEATURES:** Accessory to be used with head Part.223.  
**BOX QUANTITY:** 24 pieces.

**ON REQUEST:**

- Handles: In reinforced polypropylene, other colours.
- Box quantity: According to your request.

# Knobs and handles

## Part. 382 Ball handle

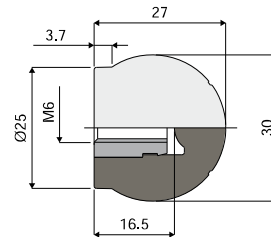
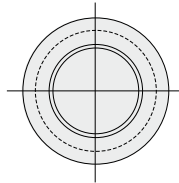

Code

382 / 84119

**MATERIALS:** Ball handle made of reinforced polyamide, black colour; threaded bushing in nickel plated brass.

**BOX QUANTITY:** 24 pieces.

**ON REQUEST:**

- Handles: Made in reinforced polypropylene, different colours.
- Box quantity: According to your request.

## Part. 383 Knob

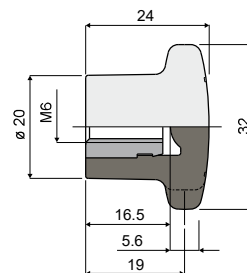
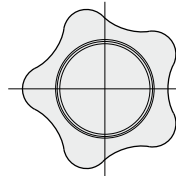

Code

383 / 84120

**MATERIALS:** Knob made of reinforced polyamide, black colour; threaded bushing in nickel plated brass.

**BOX QUANTITY:** 24 pieces.

**ON REQUEST:**

- Knobs: In reinforced polypropylene, other colours, with customized brand.
- Box quantity: According to your request.

## Part. 350 Knob

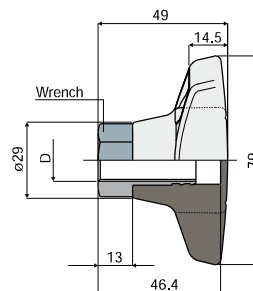
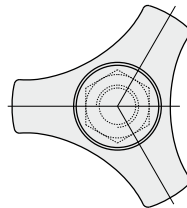

D	Wrench	Code
M12	19	350 / 83398
M16	24	350 / 83399

**MATERIALS:** Knob made of reinforced polyamide black colour; threaded bushing in nickel plated brass.

**BOX QUANTITY:** 24 pieces.

**ON REQUEST:**

- Knobs: In reinforced polypropylene, other colours, with customized brand.
- Box quantity: According to your request.

## Part. 294 Knob for bracket (reinforced type)

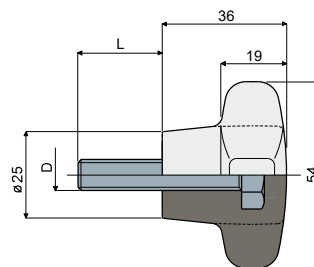
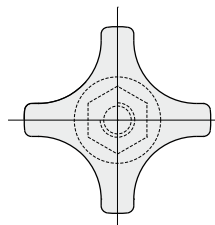

D (mm)	L (mm)	Code
M8	22	294 / 82805
M10	22	294 / 82588

**MATERIALS:** Knob made of reinforced polyamide black colour; bolt made of stainless steel AISI 304.

**FEATURES:** Accessory to be used with head Part.223.

**BOX QUANTITY:** 24 pieces.

**ON REQUEST:**

- Knobs: Made of reinforced polypropylene, in other colours, with bolts of different length and diameter.
- Box quantity: According to your request.



# Knobs and handles

## Part. 397 Ratchet handle clamping

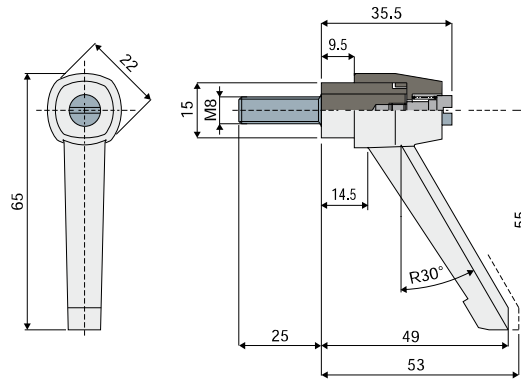

Code
397 / 84260

**MATERIALS:** Handle made of reinforced polyamide black colour; threaded insert made of stainless steel AISI 304.  
**BOX QUANTITY:** 24 pieces.  
**ON REQUEST:**

- Box quantity: According to your request.

## Part. 400 Ratchet handle clamping

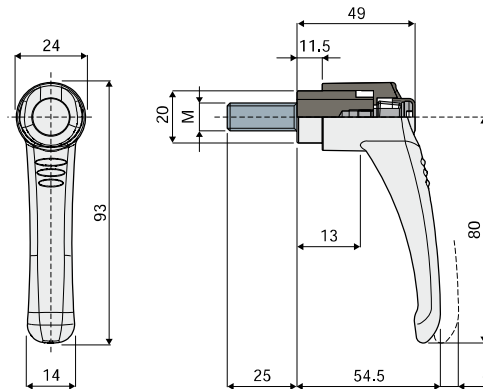

M	Code
M8	400 / 86693
M10	400 / 84316

**MATERIALS:** Handle made of reinforced polyamide black colour with push button in orange colour; threaded insert made of stainless steel AISI 304.  
**BOX QUANTITY:** 24 pieces.  
**ON REQUEST:**

- Box quantity: According to your request.

## Part. 332 Ratchet handle clamping

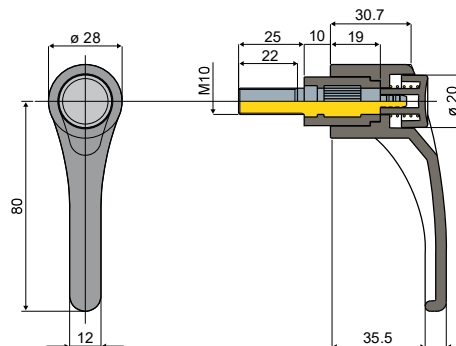

Code
332 / 83113

**MATERIALS:** Handle made of reinforced polyamide black colour with push button in orange colour; threaded insert made of zinc plated steel.  
**BOX QUANTITY:** 24 pieces.  
**ON REQUEST:**

- Handles: With threaded inserts M8, M10, M12, with different lengths; also available in stainless steel AISI 304.
- Box quantity: According to your request.



# Guide rail clamps

## Guide rail clamp Part. 230 (for trapezoidal rails)

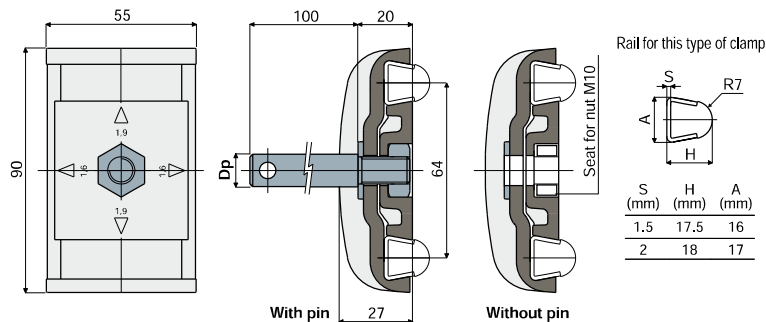

Dp Pin diameter (mm)	With pin Code	Without pin Code
12	230 / 80684	
14	230 / 80685	230 / 80611
16	230 / 80686	

**MATERIALS:** Clamp made of reinforced polyamide black colour; pin, nut and washer made of stainless steel AISI 304.  
**FEATURES:** Supplied with or without support pin. With this item it is possible to use thickness 1,5 and 2 mm guides, by rotating for 90° the central plate: Part.353, 354, 377, 418, 419, 420, 446, 469, 485, 514.  
**BOX QUANTITY:** 24 pieces.

**ON REQUEST:**

- Clamps: In reinforced polypropylene, other colours.
- Box quantity: According to your request.

## Guide rail clamp Part. 289 (for rectangular rails)

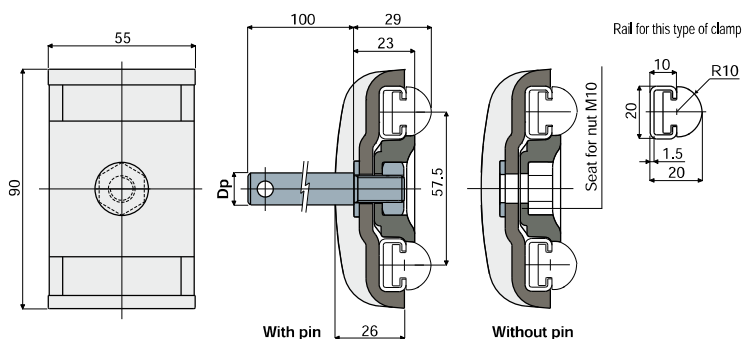

Dp Pin diameter (mm)	With pin Code	Without pin Code
12	289 / 82569	
14	289 / 82570	289 / 82572
16	289 / 82571	

**MATERIALS:** Clamp made of reinforced polyamide black colour; pin, nut and washer made of stainless steel AISI 304.  
**FEATURES:** Supplied with or without support pin. To be used for the support of the product guide rail Part.373.  
**BOX QUANTITY:** 24 pieces.

**ON REQUEST:**

- Clamps: In reinforced polypropylene, other colours.
- Box quantity: According to your request.

## Guide rail clamp Part. 229 (for round rails)

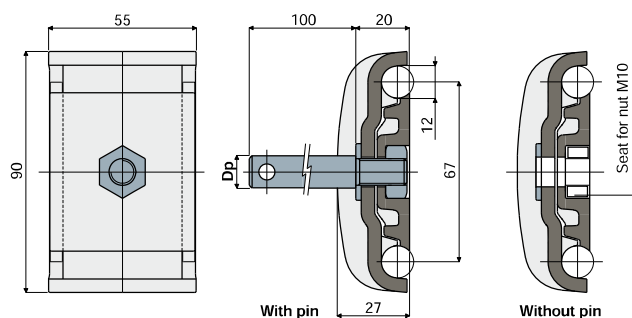

Dp Pin diameter (mm)	With pin Code	Without pin Code
12	229 / 80681	
14	229 / 80682	229 / 80609
16	229 / 80683	

**MATERIALS:** Clamp made of reinforced polyamide black colour; pin, nut and washer made of stainless steel AISI 304.  
**FEATURES:** Supplied with or without support pin.  
**BOX QUANTITY:** 24 pieces.

**ON REQUEST:**

- Clamps: In reinforced polypropylene, other colours.
- Box quantity: According to your request.

# Guide rail clamps

## Part. 231

### Guide rail clamp (for round rails)

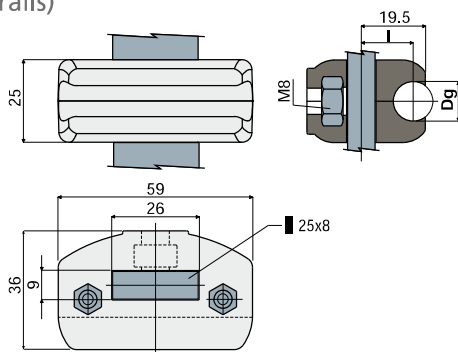

Dg Rail diameter (mm)	l (mm)	Code
8	16	231 / 80749
10	15	231 / 80788
12	15	231 / 80687
14	15	231 / 80787

**MATERIALS:** Clamp made of reinforced polyamide black colour; bolts and nuts made of stainless steel AISI 304.  
**FEATURES:** Supplied assembled. To be used with flat support with sizes 25x8 mm.  
**BOX QUANTITY:** 24 pieces.  
**ON REQUEST:**

- Clamps: In reinforced polypropylene, other colours.
- Box quantity: According to your request.

### Example of application

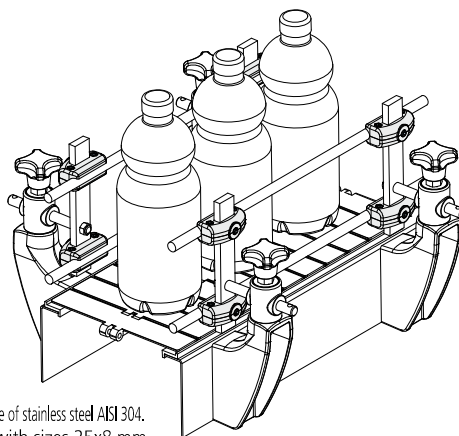

## Part. 232

### Guide rail clamp (for trapezoidal rails)

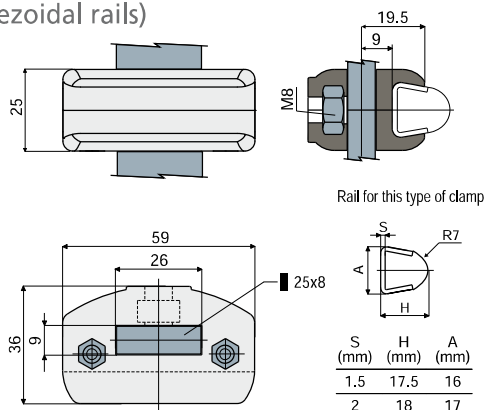

Code
232 / 80688

**MATERIALS:** Clamp made of reinforced polyamide black colour; bolts and nuts made of stainless steel AISI 304.  
**FEATURES:** Supplied assembled. To be used with flat support with sizes 25x8 mm. With this item it is possible to use thickness 1,5 and 2 mm guides: Part.353, 354, 377, 418, 419, 420, 446, 469, 485, 514.  
**BOX QUANTITY:** 24 pieces.  
**ON REQUEST:**

- Clamps: In reinforced polypropylene, other colours.
- Box quantity: According to your request.

### Example of application

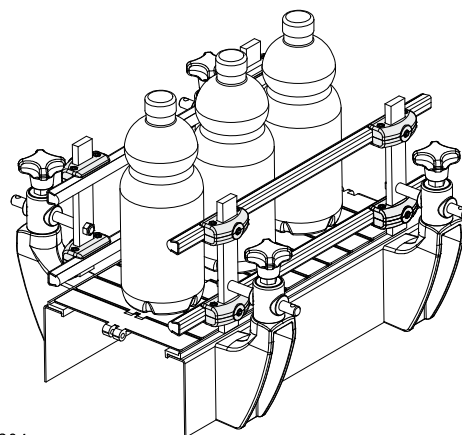

## Part. 291

### Guide rail clamp (for rectangular rails)

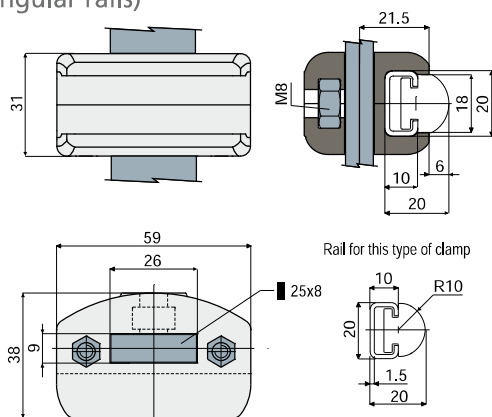

Code
291 / 82578

**MATERIALS:** Clamp made of reinforced polyamide black colour; bolts and nuts made of stainless steel AISI 304.  
**FEATURES:** Supplied assembled. To be used with flat profile with sizes 25x8 mm. To be used for the support of the product guide rail Part.373.  
**BOX QUANTITY:** 24 pieces.  
**ON REQUEST:**

- Clamps: In reinforced polypropylene, other colours.
- Box quantity: According to your request.

### Example of application

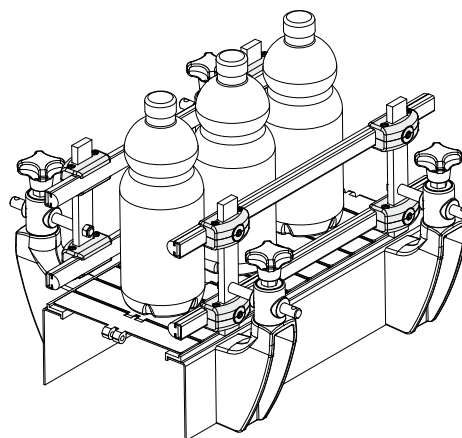

# Guide rail clamps

## Guide rail clamp (for round rails)

### Part. 483

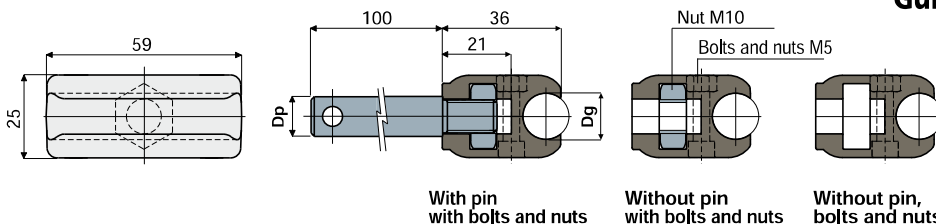

Dp Pin diameter (mm)	Dg Rail diameter (mm)	With pin with bolts and nuts		Without pin with bolts and nuts	
		Code		Code	
12	8	483 / 87024		483 / 86156	
	10	483 / 87025		483 / 86151	
	12	483 / 87026		483 / 86152	
	14	483 / 87027		483 / 86153	
14	8	483 / 87028			
	10	483 / 87029			
	12	483 / 87030			
16	14	483 / 87031			
	8	483 / 87032		483 / 87036	
	10	483 / 87033		483 / 87037	
	12	483 / 87034		483 / 87038	
	14	483 / 87035		483 / 87039	

**MATERIALS:** Clamp made of reinforced polyamide black colour; pin, bolts and nuts made of stainless steel AISI 304.

**FEATURES:** Supplied with or without support pin and with or without bolts and nuts.

**BOX QUANTITY:** 24 pieces.

**ON REQUEST:**

- Clamps: In reinforced polypropylene, other colours.
- Box quantity: According to your request.

## Guide rail clamp (for trapezoidal rails)

### Part. 484

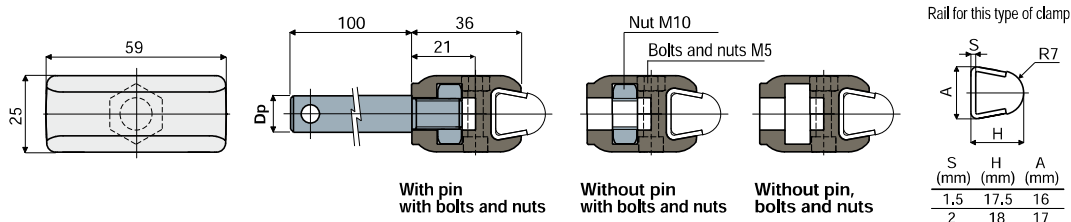

**MATERIALS:** Clamp made of reinforced polyamide black colour; pin, bolts and nuts made of stainless steel AISI 304.

**FEATURES:** Supplied with or without support pin and with or without bolts and nuts. With this item it is possible to use thickness 1,5 and 2 mm guides: Part.353, 354 377, 418, 419, 420, 446, 469, 485, 514.

**BOX QUANTITY:** 24 pieces.

**ON REQUEST:**

- Clamps: In reinforced polypropylene, other colours.
- Box quantity: According to your request.

Dp Pin diameter (mm)	With pin with bolts and nuts		Without pin with bolts and nuts	Without pin, bolts and nuts
	Code		Code	Code
12	484 / 87040			
14	484 / 87041		484 / 86154	484 / 87043
16	484 / 87042			

## Guide rail clamp (for rectangular rail)

### Part. 290

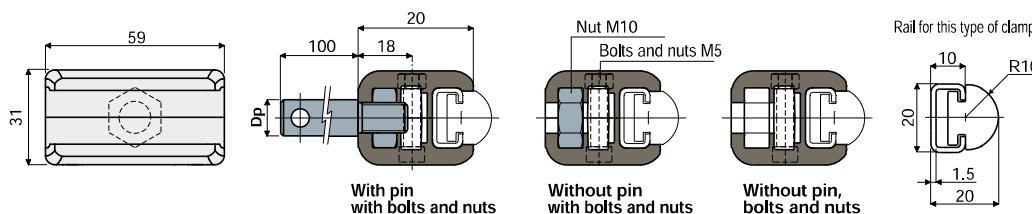

Dp Pin diameter (mm)	With pin with bolts and nuts		Without pin with bolts and nuts	Without pin, bolts and nuts
	Code		Code	Code
12	290 / 82573			
14	290 / 82574		290 / 82576	
16	290 / 82575			290 / 82577

**MATERIALS:** Clamp made of reinforced polyamide black colour; pin, bolts and nuts made of stainless steel AISI 304.

**FEATURES:** Supplied with or without support pin. To be used for the support of the product guide rail Part.373.

**BOX QUANTITY:** 24 pieces.

**ON REQUEST:**

- Clamps: In reinforced polypropylene, other colours.
- Box quantity: According to your request.

# Guide rail clamps

## Part. 346

### Guide rail clamp (for round rails)

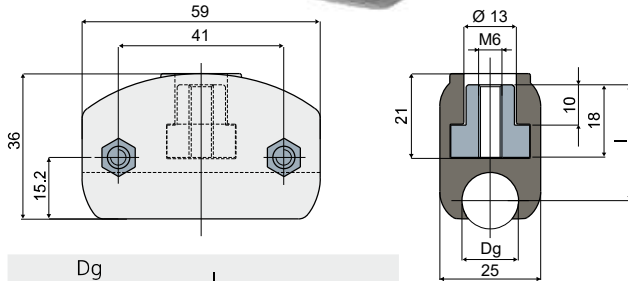

Dg Rail diameter (mm)	l (mm)	Code
8	30	346 / 83390
10	29,5	346 / 83391
12	29,5	346 / 83392
14	28,7	346 / 83393

**MATERIALS:** Clamp made of reinforced polyamide black colour; threaded insert in nickel plated brass; bolts and nuts in stainless steel AISI 304.

**FEATURES:** Designed appositely to be assembled directly on the pneumatic cylinder for the rails regulation. Supplied assembled.

**BOX QUANTITY:** 24 pieces.

**ON REQUEST:**

- Clamps: In reinforced polypropylene, other colours.
- Box quantity: According to your request.

Example of application

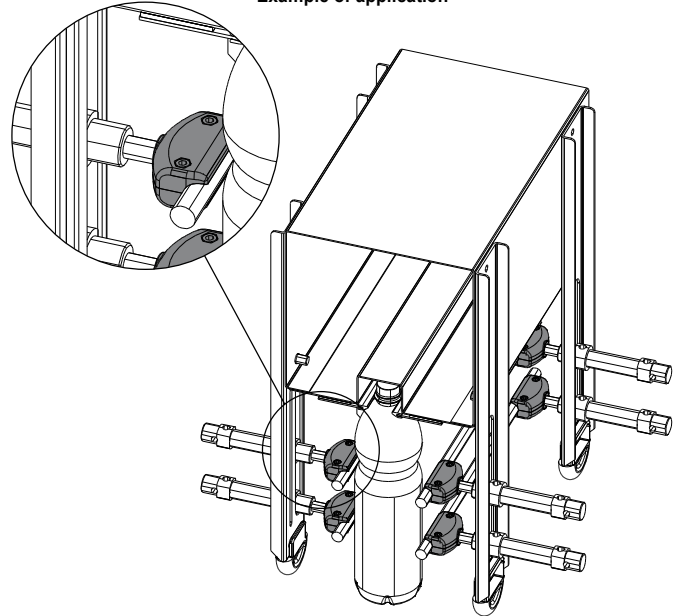

## Part. 347

### Guide rail clamp (for trapezoidal rails)

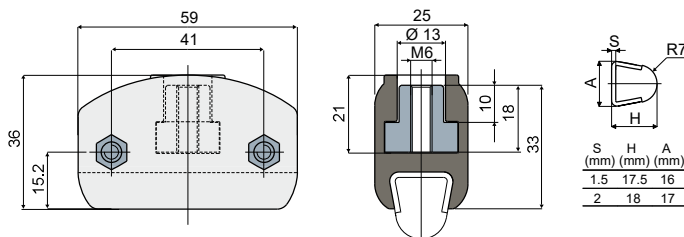

Code  
347 / 83394

**MATERIALS:** Clamp made of reinforced polyamide black colour; threaded insert in nickel plated brass; bolts and nuts in stainless steel AISI 304.

**FEATURES:** Designed appositely to be assembled directly on the pneumatic cylinder for the rails regulation. With this item it is possible to use thickness 1,5 and 2 mm guides: Part.353, 354, 377, 418, 419, 420, 446, 469, 485, 514. Supplied assembled.

**BOX QUANTITY:** 24 pieces.

**ON REQUEST:**

- Clamps: In reinforced polypropylene, other colours.
- Box quantity: According to your request.

Example of application

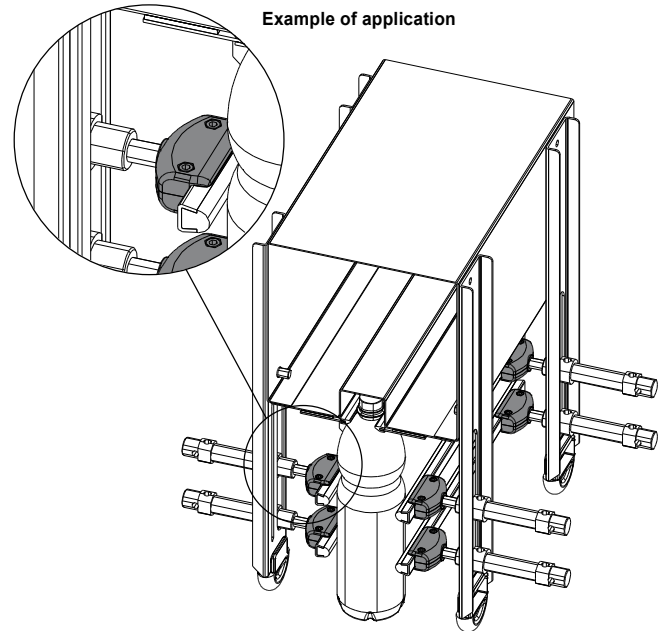

# Guide rail clamps

Example of application

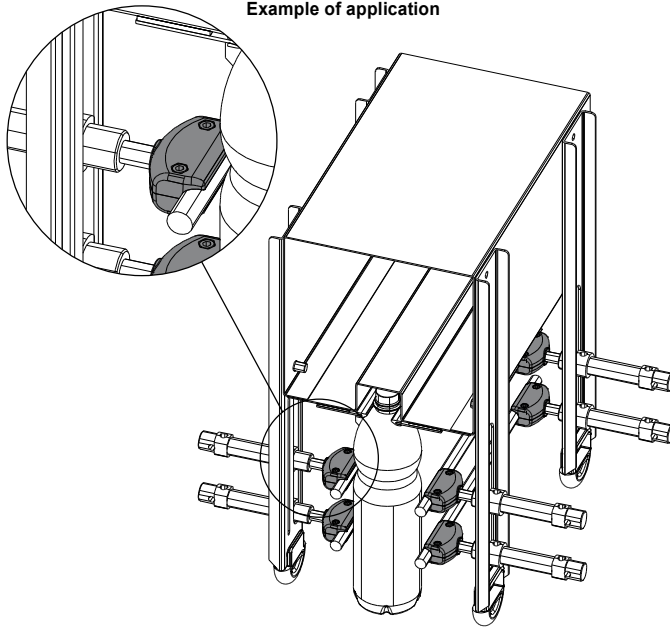

## Guide rail clamp (for round rails)

Part. **348**

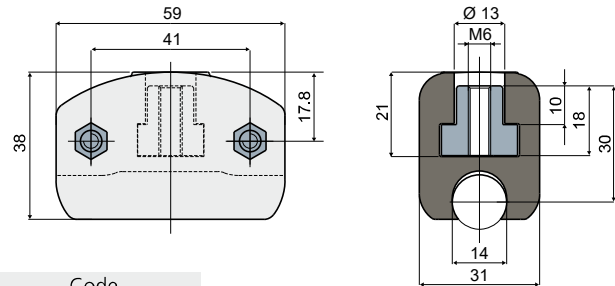

Code

348 / 83395

**MATERIALS:** Clamp made of reinforced polyamide black colour; threaded insert in nickel plated brass; bolts and nuts in stainless steel AISI 304.

**FEATURES:** Designed appositely to be assembled directly on the pneumatic cylinder for the rails regulation. Supplied assembled.

**BOX QUANTITY:** 24 pieces.

**ON REQUEST:**

- Clamps: In reinforced polypropylene, other colours.
- Box quantity: According to your request.

Example of application

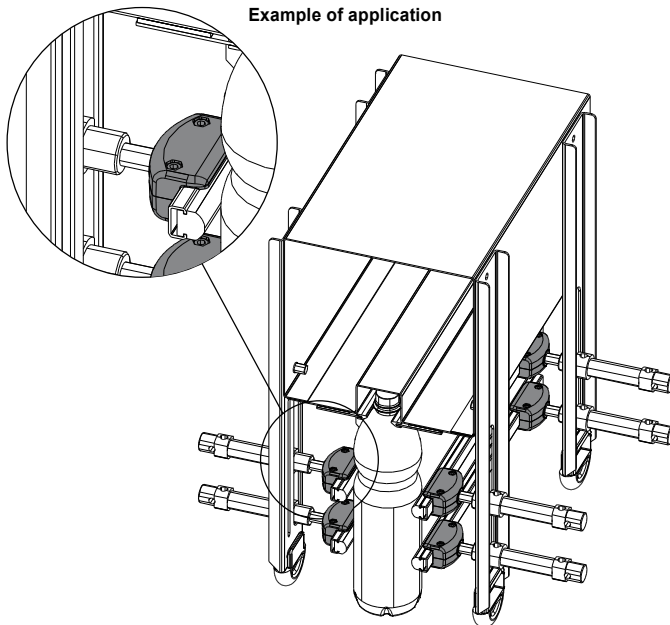

## Guide rail clamp (for rectangular rails)

Part. **349**

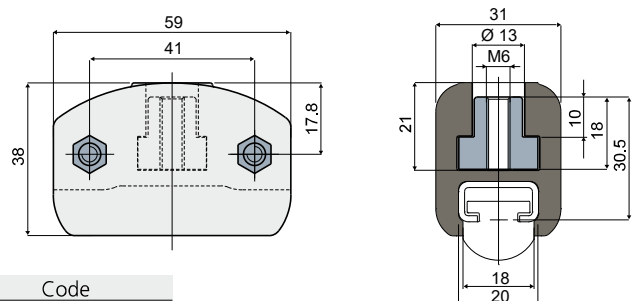

Code

349 / 83396

**MATERIALS:** Clamp made of reinforced polyamide black colour; threaded insert in nickel plated brass; bolts and nuts in stainless steel AISI 304.

**FEATURES:** Designed appositely to be assembled directly on the pneumatic cylinder for the rails regulation. To be used for the support of the product guide rail Part.373. Supplied assembled.

**BOX QUANTITY:** 24 pieces.

**ON REQUEST:**

- Clamps: In reinforced polypropylene, other colours.
- Box quantity: According to your request.

# Guide rail clamps

## Part. 301 Threaded pin

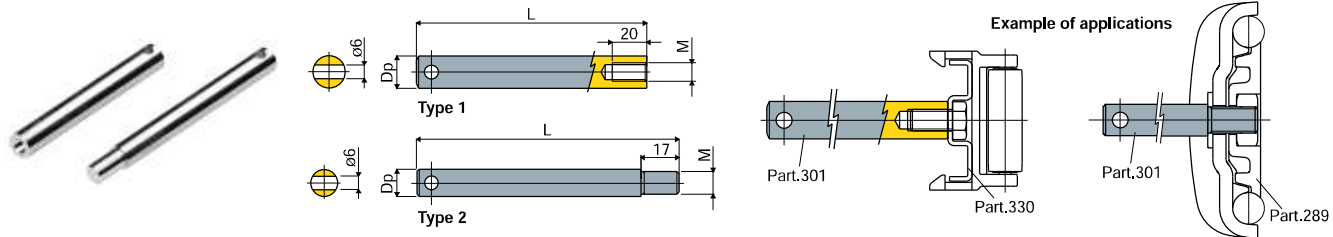

Dp (mm)	L (mm)	M (mm)	Type 1 Code
12	100	M8	301 / 86707
14	100	M8	301 / 82751
16	100	M8	301 / 86708

Dp (mm)	L (mm)	M (mm)	Type 2 Code
12	117	M10	301 / 83304
12	150	M8	301 / 85381
12	167	M10	301 / 84869
12	217	M10	301 / 83871
14	117	M10	301 / 83305
16	117	M10	301 / 83306
16	121	M10	301 / 84109

**MATERIALS:** Pin made of stainless steel AISI 304.

**FEATURES:**

- Type 1: Can be mounted both on guide rail clamps or on side guides;
- Type 2: Used for the mounting of Part. 289, 229, 230, 290, 204, 205.

**BOX QUANTITY:** 24 pieces.

**ON REQUEST:**

- Pins: In various lengths.
- Box quantity: According to your request.

## Part. 460 Threaded pin for guide rail clamp

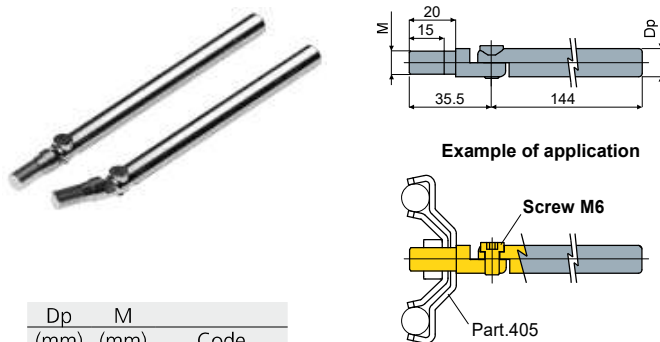

Dp (mm)	M (mm)	Code
12	M10	460 / 85470
14	M10	460 / 85566

**MATERIALS:** Pin made of stainless steel AISI 304.

**FEATURES:** Supplied complete with bolts and nuts.

**BOX QUANTITY:** 24 pieces.

**ON REQUEST:**

- Pins: In various lengths.
- Box quantity: According to your request.

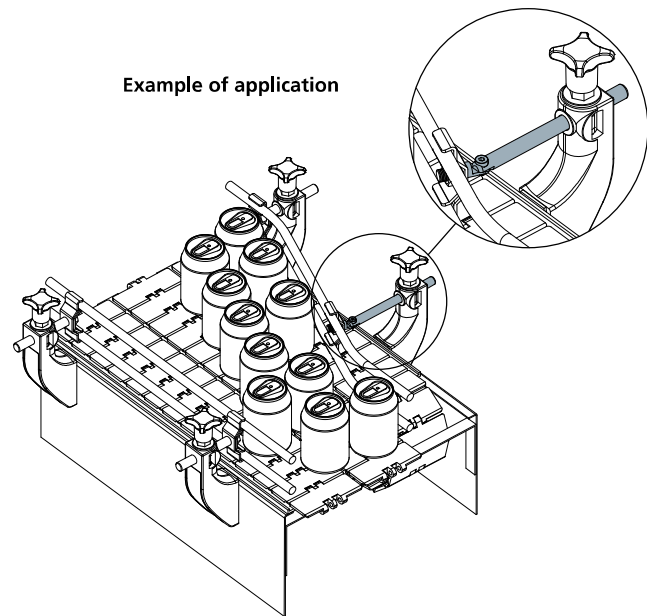

## Part. 398 Cap for pins

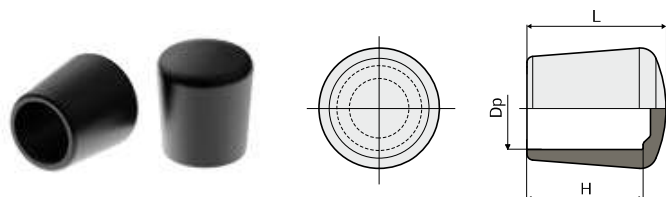

Dp (mm)	H (mm)	L (mm)	Code
12	17	21	398 / 84258
14	18	23	398 / 84259
16	20	25	398 / 85592

**MATERIALS:** Cap made of thermoplastic rubber.

**FEATURES:** To be applied at the ends of the pins.

**BOX QUANTITY:** 24 pieces.

**ON REQUEST:**

- Box quantity: According to your request.



# Guide rail clamps

## Guide rail clamp Part. 204 (for round rails)

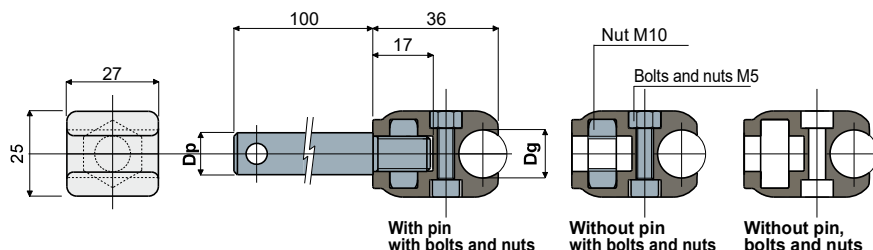

Dp Pin diameter (mm)	Dg Rail diameter (mm)	With pin with bolts and nuts	
		Code	
12	8	204 / 80798	
	10	204 / 80799	
	12	204 / 80800	
	14	204 / 80801	
14	8	204 / 80802	
	10	204 / 80803	
	12	204 / 80804	
	14	204 / 80805	
16	8	204 / 80806	
	10	204 / 80807	
	12	204 / 80808	
	14	204 / 80809	

Dg Rail diameter (mm)	Without pin with bolts and nuts	
	Code	
8	204 / 80810	
10	204 / 80811	
12	204 / 80812	
14	204 / 80813	

Dg Rail diameter (mm)	Without pin, bolts and nuts	
	Code	
8	204 / 80978	
10	204 / 80979	
12	204 / 80980	
14	204 / 80981	

**MATERIALS:** Clamp made of reinforced polyamide black colour; pin, bolts and nuts made of stainless steel AISI 304.

**FEATURES:** Supplied with or without support pin and with or without bolts and nuts.

**BOX QUANTITY:** 24 pieces.

**ON REQUEST:**

- Clamps: In reinforced polypropylene, other colours.
- Box quantity: According to your request.

## Guide rail clamp Part. 205 (for trapezoidal rails)

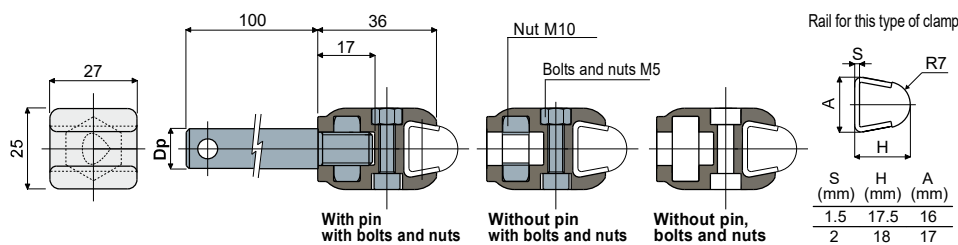

Dp Pin diameter (mm)	With pin with bolts and nuts		Without pin with bolts and nuts		Without pin, bolts and nuts	
	Code		Code		Code	
12	205 / 80814					
14	205 / 80815		205 / 80817		205 / 80982	
16	205 / 80816					

**MATERIALS:** Clamp made of reinforced polyamide black colour; pin, bolts and nuts made of stainless steel AISI 304.

**FEATURES:** Supplied with or without support pin and with or without bolts and nuts. With this item it is possible to use thickness 1,5 and 2 mm guides:

Part.353, 354, 377, 418, 419, 420, 446, 469, 485, 514.

**BOX QUANTITY:** 24 pieces.

**ON REQUEST:**

- Clamps: In reinforced polypropylene, other colours.
- Box quantity: According to your request.



# Guide rail clamps

## Part. 412 Guide rail clamp

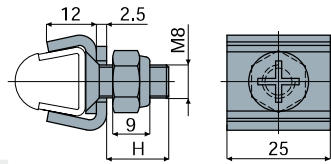

H	Code
15	412 / 84487
20	412 / 87351

**MATERIALS:** Clamp, bolts and nuts made of stainless steel AISI 304.

**FEATURES:** With this item it is possible to use thickness 1,5 and 2 mm guides:  
Part.353, 354, 377, 418, 419, 420, 446, 469, 485, 514.

**BOX QUANTITY:** 24 pieces.

**ON REQUEST:**

- Box quantity: According to your request.
- Assembly of: Bolts and nuts.

## Part. 413 Guide rail clamp (for connection)

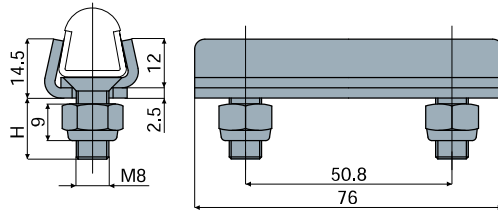

H	Code
15	413 / 84488
20	413 / 87361

**MATERIALS:** Clamp, bolts and nuts made of stainless steel AISI 304.

**FEATURES:** With this item it is possible to use thickness 1,5 and 2 mm guides:  
Part.353, 354, 377, 418, 419, 420, 446, 469, 485, 514.

**BOX QUANTITY:** 24 pieces.

**ON REQUEST:**

- Box quantity: According to your request.
- Assembly of: Bolts and nuts.

## Part. 521 Guide rail clamp (for Part.501, 502)

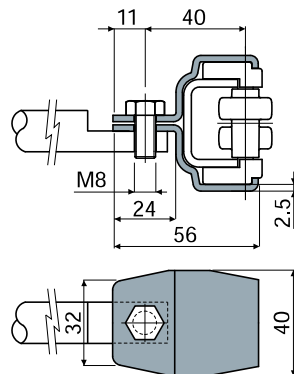

Material	Code
Zinc plated steel	521 / 87310
Stainless steel AISI 304	521 / 87311

**MATERIALS:** Clamp made in zinc plated steel or in stainless steel AISI 304.

**FEATURES:** To be used with Part.501, 502. If mounted on double, triple or quadruple type side guides, use a suitable spacer (see drawing opposite).

**BOX QUANTITY:** 24 pieces.

**ON REQUEST:**

- Box quantity: According to your request.

### Example of application

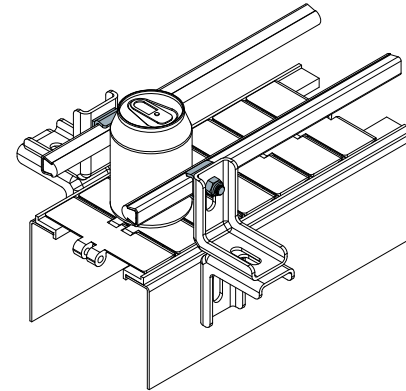

### Example of application

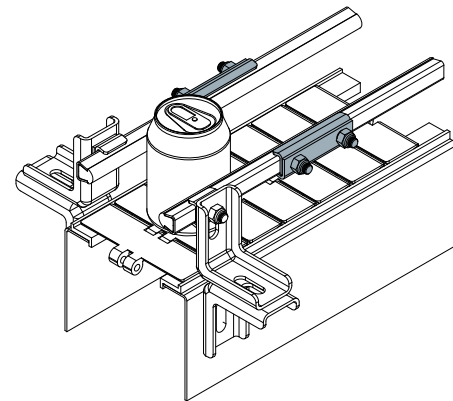

### Example of applications

#### Double type side guide

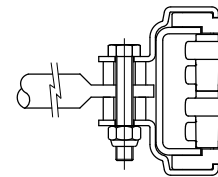

#### Triple type side guide

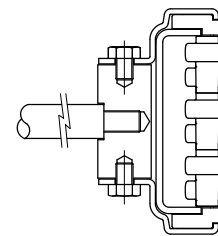

#### Quadruple type side guide

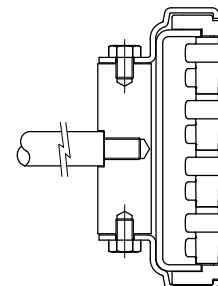

# Guide rail clamps

Example of application

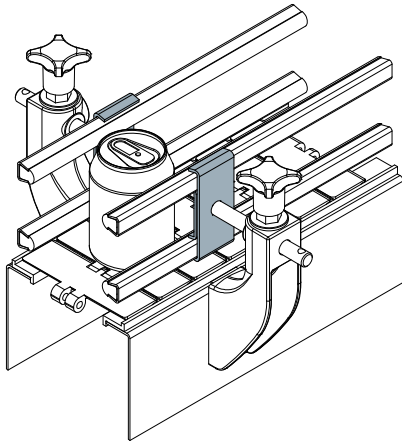

Example of application

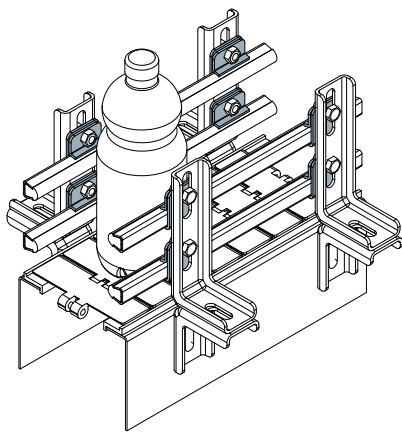

Example of application

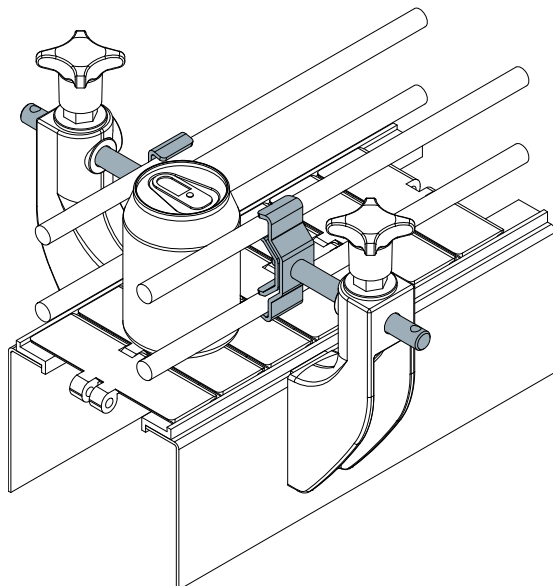

## Guide rail clamp (double)

Part. **410**

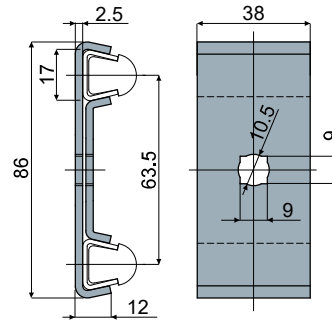

Code
410 / 84485

**MATERIALS:** Clamp made of stainless steel AISI 304.

**FEATURES:** With this item it is possible to use thickness 1,5 and 2 mm guides: Part.353, 354, 377, 418, 419, 420, 446, 469, 485, 514.

**BOX QUANTITY:** 24 pieces.

**ON REQUEST:**

- Box quantity: According to your request.

## Guide rail clamp

Part. **411**

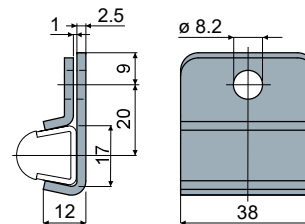

Code
411 / 84486

**MATERIALS:** Clamp made of stainless steel AISI 304.

**FEATURES:** With this item it is possible to use thickness 1,5 and 2 mm guides: Part.353, 354, 377, 418, 419, 420, 446, 469, 485, 514.

**BOX QUANTITY:** 24 pieces.

**ON REQUEST:**

- Box quantity: According to your request.

## Guide rail clamp (for round rails)

Part. **405**

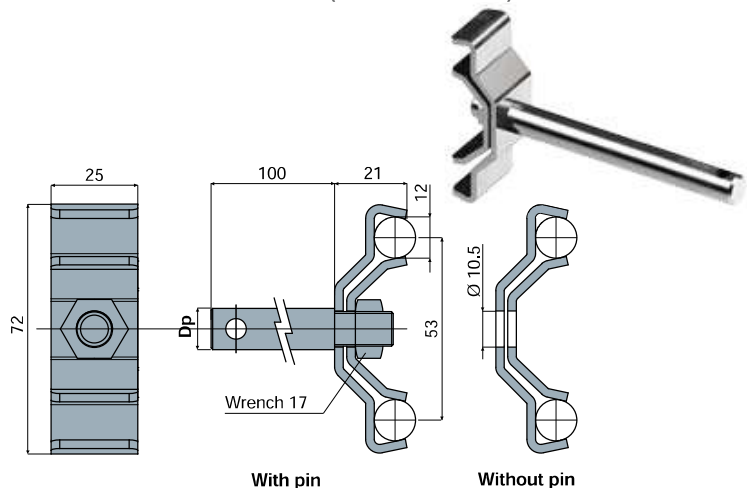

Dp Pin diameter (mm)	With pin Code	Without pin Code
12	405 / 84327	
14	405 / 84442	405 / 85101
16	405 / 84443	

**MATERIALS:** Clamp, mounting plate, nut and threaded pin made of stainless steel AISI 304.

**FEATURES:** Supplied with or without pin.

**BOX QUANTITY:** 24 pieces.

**ON REQUEST:**

- Box quantity: According to your request.
- Assembly of: Bolts and nuts.

# Guide rail clamps

## Part. 424 Guide rail clamp

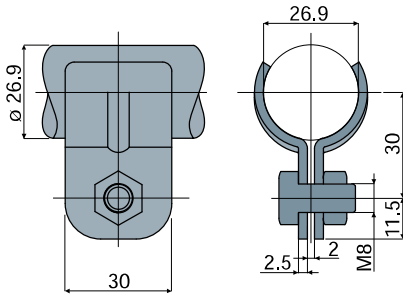

Code

424 / 84961

MATERIALS: Clamp, bolts and nuts in stainless steel AISI 304.

BOX QUANTITY: 24 pieces.

ON REQUEST:

- Box quantity: According to your request.
- Assembly of: Bolts and nuts.

### Example of application

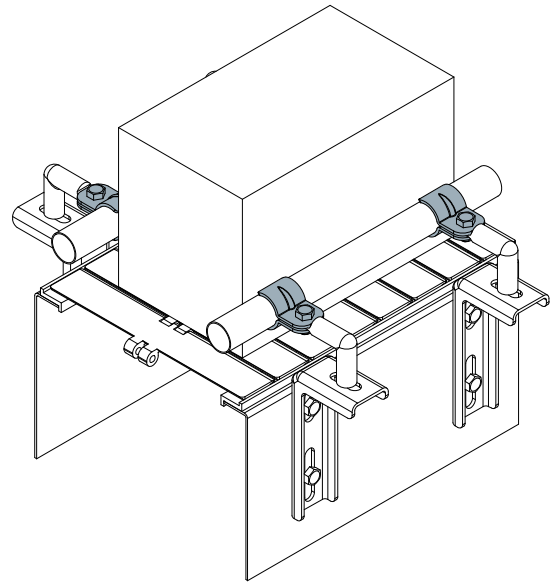

## Part. 443 Guide rail clamp

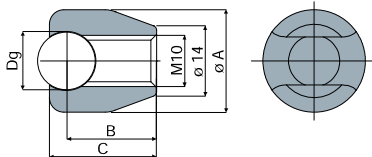

Dg Rail diameter (mm)	Code	Ø A (mm)	B (mm)	C (mm)
10	443 / 87657	21	17.5	20
12	443 / 85275	21	18.5	22
14	443 / 87658	21	19.5	24

MATERIALS: Clamp made of stainless steel AISI 304.

BOX QUANTITY: 24 pieces.

ON REQUEST:

- Box quantity: According to your request.

### Example of application

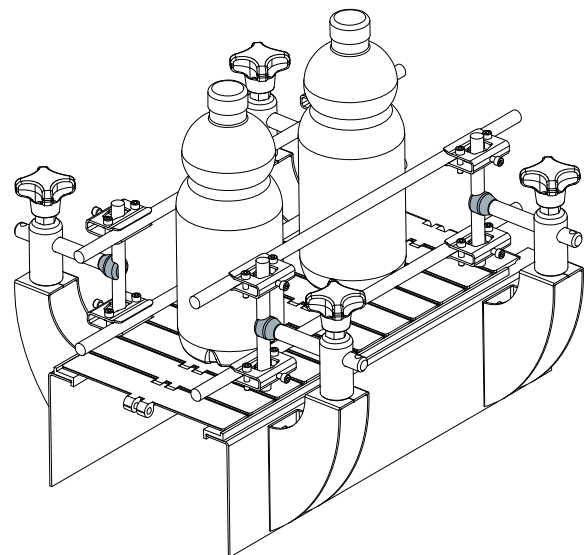

# Guide rail clamps

Example of application

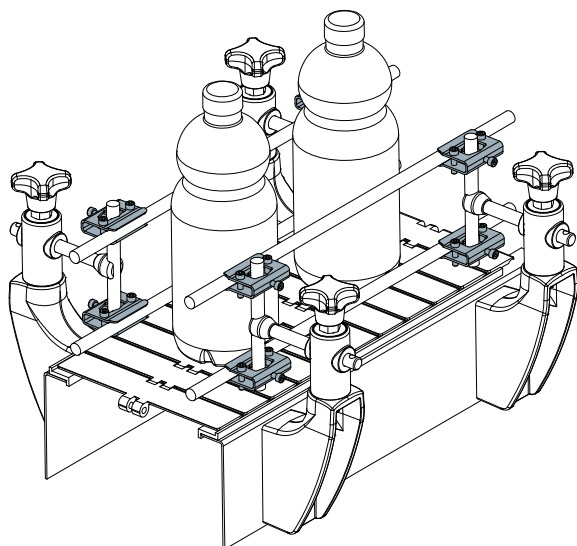

## Guide rail clamp (for round rails)

Part. **440**

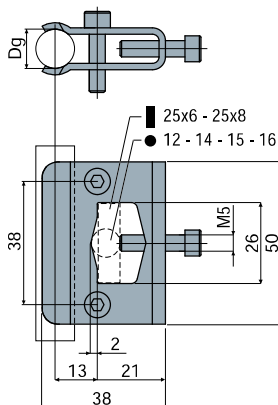

Dg Rail diameter (mm)	Code
12	440 / 85240

**MATERIALS:** Clamp, bolts and nuts in stainless steel AISI 304.

**FEATURES:** Supplied with bolts and nuts.

**BOX QUANTITY:** 24 pieces.

**ON REQUEST:**

- Box quantity: According to your request.

Example of application

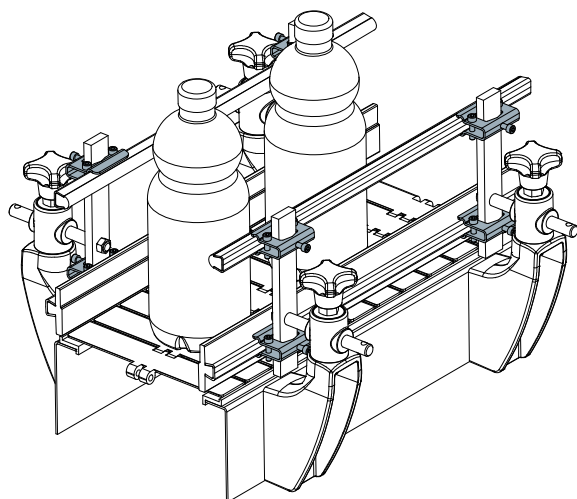

## Guide rail clamp (for trapezoidal rails)

Part. **439**

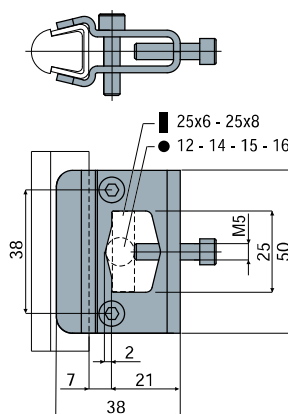

Code
439 / 85239

**MATERIALS:** Clamp, bolts and nuts in stainless steel AISI 304.

**FEATURES:** With this item it is possible to use thickness 1,5 and 2 mm guides.

Part.353, 354, 377, 418, 419, 420, 446, 469, 485, 514. Supplied with bolts and nuts.

**BOX QUANTITY:** 24 pieces.

**ON REQUEST:**

- Box quantity: According to your request.

# Guide rail clamps

## Part. 470 Cross clamp

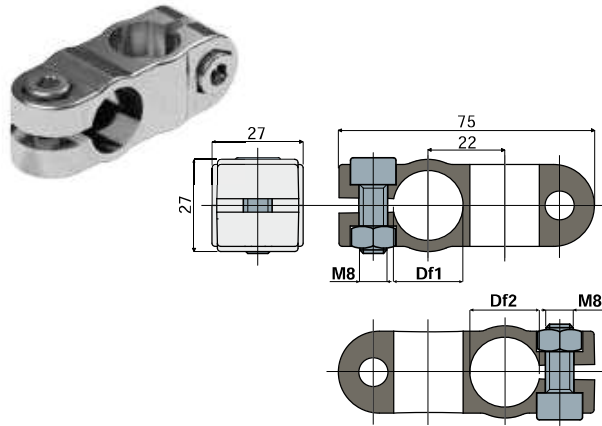

Bore for pin of		Version with bolts and nuts	Version without bolts and nuts
Df1 round (mm)	Df2 round (mm)		
16	16	470 / 85598	470 / 86710
16	20	470 / 85599	470 / 86711
20	20	470 / 85600	470 / 86712

**MATERIALS:** Clamp, bolts and nuts in stainless steel AISI 304.

**BOX QUANTITY:** 24 pieces.

**ON REQUEST:**

- Box quantity: According to your request.

## Part. 531 Guide rail clamp

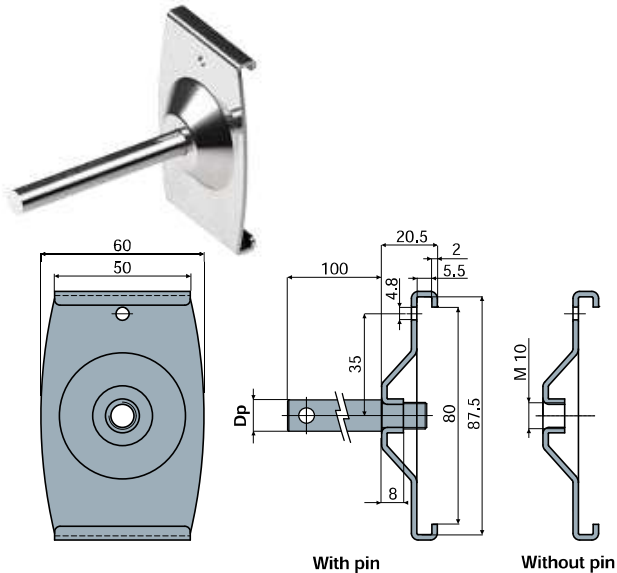

Dp Pin diameter (mm)	With pin Code	Without pin Code
12	531 / 87758	
14	531 / 87759	531 / 87761
16	531 / 87760	

**MATERIALS:** Clamp, threaded pin, washer and nut in stainless steel AISI 304.

**FEATURES:** Supplied with or without pin. To be used with side guide Part. 528.

**BOX QUANTITY:** 24 pieces.

**ON REQUEST:**

- Assembling of: Pins, washers and nuts.
- Box quantity: According to your request.

### Example of application

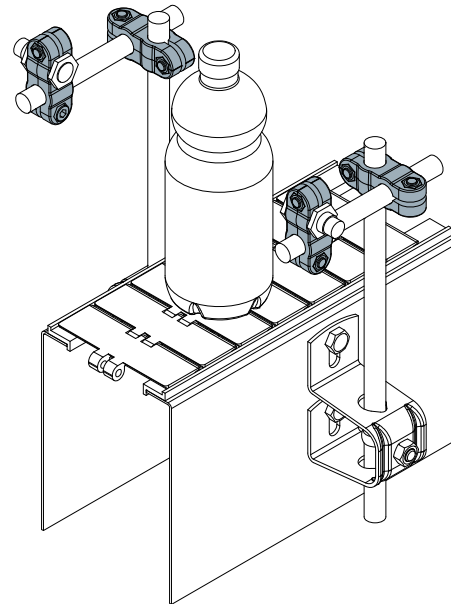

### Example of application

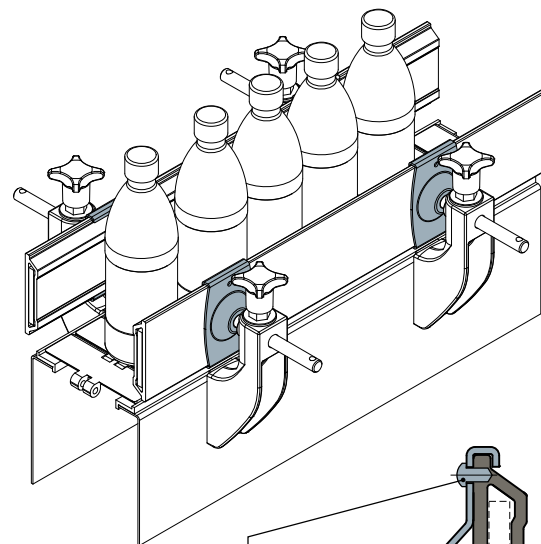

it is possible to fix the clamp to the plastic profile by using a self-tapping screw 4,8x9,5 DIN7981

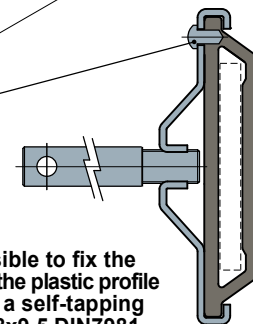

# Guide rail clamps

Example of application

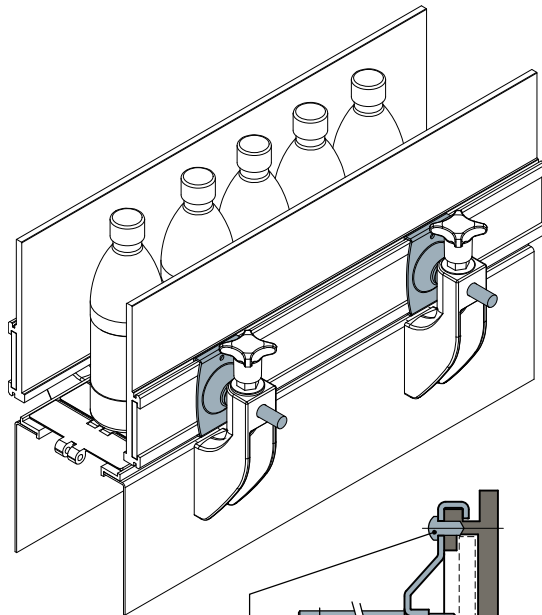

it is possible to fix the clamp to the plastic profile by using a self-tapping screw 4,8x9,5 DIN7981

Example of application

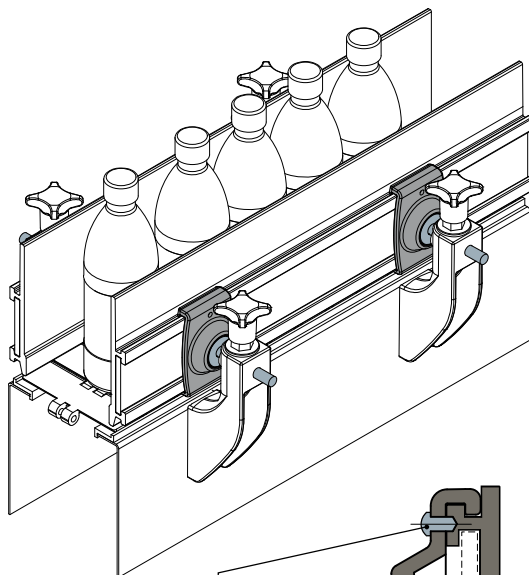

it is possible to fix the clamp to the plastic profile by using a self-tapping screw 4,8x9,5 DIN7981

## Guide rail clamp

Part. **427**

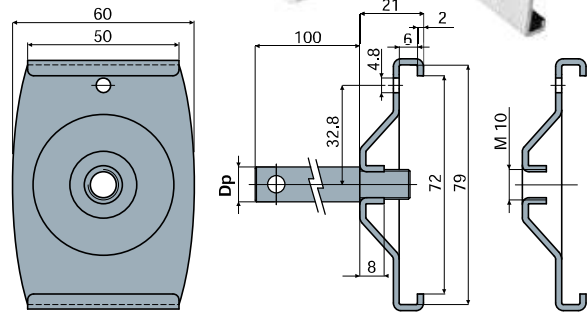

Dp Pin diameter (mm)	With pin Code	Without pin Code
12	427 / 85097	
14	427 / 85098	427 / 85009
16	427 / 85099	

**MATERIALS:** Clamp, threaded pin, washer and nut in stainless steel AISI 304.  
**FEATURES:** Supplied with or without pin. To be used with side guides Part. 425, 426, 463.  
**BOX QUANTITY:** 24 pieces.

**ON REQUEST:**

- Assembling of: Pins, washers and nuts.
- Box quantity: According to your request.

## Guide rail clamp

Part. **434**

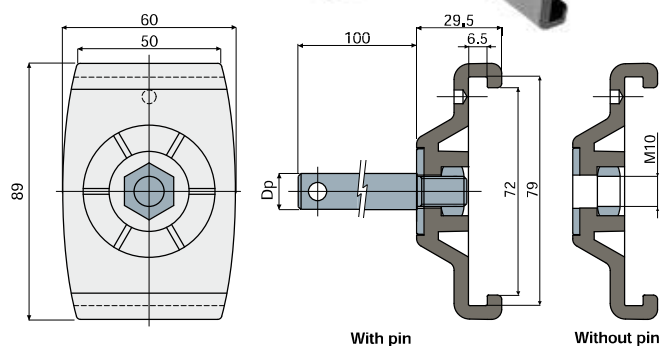

Dp Pin diameter (mm)	With pin Code	Without pin Code
12	434 / 85093	
14	434 / 85094	434 / 85100
16	434 / 85095	

**MATERIALS:** Clamp is made of reinforced polyamide; threaded pin, washer and nut in stainless steel AISI 304.  
**FEATURES:** Supplied with or without pin. To be used with side guides Part. 425, 426, 463.  
**BOX QUANTITY:** 8 pieces.

**ON REQUEST:**

- Assembling of: Pins, washers and nuts.
- Box quantity: According to your request.



# Clamps

Part. **206** **Clamp support for photocells**  
(for photocells and reflectors)

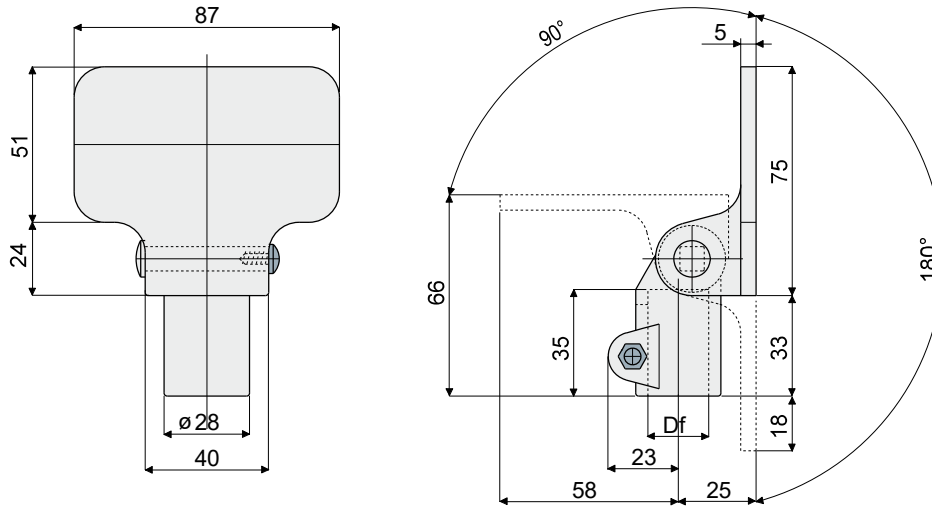

Df Bore for pin of (mm)	Code
12	206 / 82010 (can be used also with square pins 10x10)
14	206 / 80818
15	206 / 80819
16	206 / 80820
18	206 / 80821
20	206 / 80822

**MATERIALS:** Clamp made of reinforced polyamide black colour; bolts and nuts made of stainless steel AISI 304.

**FEATURES:** Possibility of assembly in various positions.

**BOX QUANTITY:** 24 pieces.

**ON REQUEST:**

- Clamps: In reinforced polypropylene, other colours.
- Box quantity: According to your request.





# Clamps

## Part. 238 "T" clamp (to support rails and photocells)

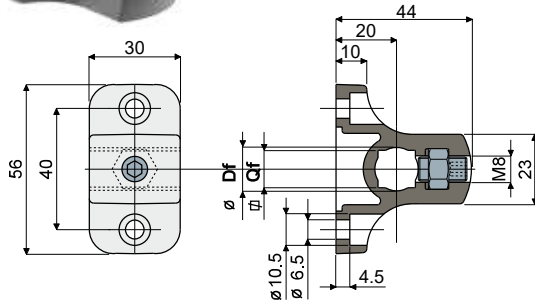

Bore for pin of		Code
Df round (mm)	Qf square (mm)	
10	8	238 / 80985
12	10	238 / 80986
14	12	238 / 80987

**MATERIALS:** Clamp made of reinforced polyamide black colour; screw and nuts made of stainless steel AISI 304.

**FEATURES:** This part can be used with round and square pins either.

**BOX QUANTITY:** 24 pieces.

**ON REQUEST:**

- Clamps: With different bores sizes, in reinforced polypropylene, other colours.
- Box quantity: According to your request.

## Part. 324 Spacer for clamp (for "T" clamp Part. 238)

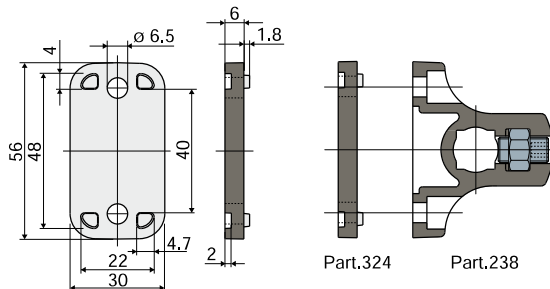

Code
324 / 82971

**MATERIALS:** Spacer made of reinforced polyamide black colour.

**FEATURES:** Accessory to be applied to "T" clamp Part.238.

**BOX QUANTITY:** 24 pieces.

**ON REQUEST:**

- Spacers: In reinforced polypropylene, other colours.
- Box quantity: According to your request.

### Example of applications

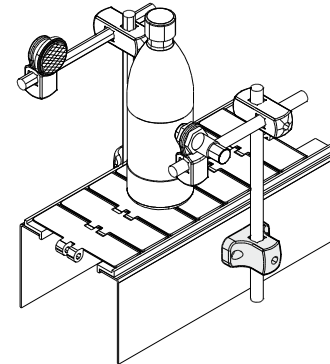

To support photocells

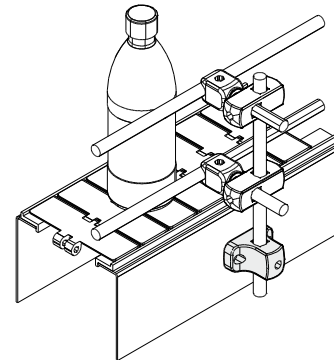

To support guide

### Example of application

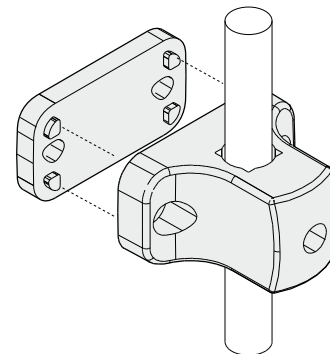

# Clamps

Example of application

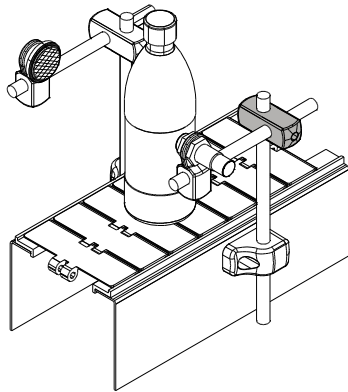

**Cross clamp Part. 239**

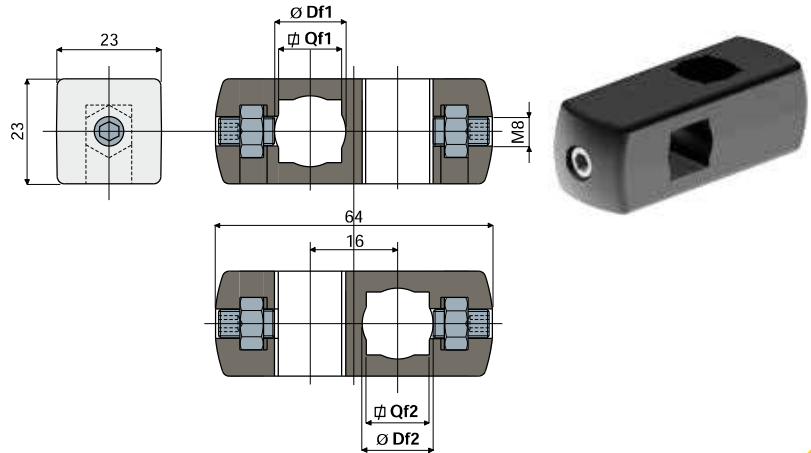

Bore for pin of		Bore for pin of		Code
Df1	Qf1	Df2	Qf2	
round (mm)	square (mm)	round (mm)	square (mm)	
10	8	10	8	239 / 80993
12	10	12	10	239 / 80994
14	12	14	12	239 / 80995

**MATERIALS:** Clamp made of reinforced polyamide black colour; bolts and nuts made of stainless steel AISI 304.

**FEATURES:** This part can be used with round and square pins either.

**BOX QUANTITY:** 24 pieces.

**ON REQUEST:**

- Clamps: With different bores sizes, in reinforced polypropylene, other colours.
- Box quantity: According to your request.

Example of application

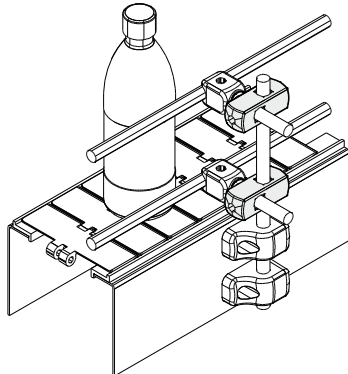

**Cross clamp Part. 241**

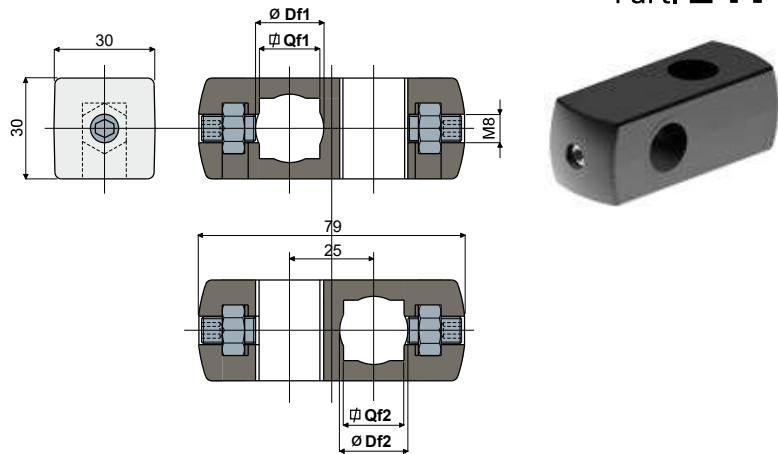

Bore for pin of		Bore for pin of		Code
Df1	Qf1	Df2	Qf2	
round (mm)	square (mm)	round (mm)	square (mm)	
14	12	14	12	241 / 80988
15	-	15	-	241 / 80989
16	-	16	-	241 / 80990
18	-	18	-	241 / 80991
20	-	20	-	241 / 80992

**MATERIALS:** Clamp made of reinforced polyamide black colour; bolts and nuts made of stainless steel AISI 304.

**FEATURES:** This part can be used with round and square pins either, only in the version Df1 14.

**BOX QUANTITY:** 24 pieces.

**ON REQUEST:**

- Clamps: With different bores sizes, in reinforced polypropylene, other colours.
- Box quantity: According to your request.