

This is the Original Document in English Language



The designation ATEX (Atmosphere Explosibles) has established itself for the new guidelines. ATEX 100a controls all regulations for the condition of explosion-proof equipment.

Model No. _____ Category _____ Reference _____
Mfg Year _____ Max Temperature _____

1. General Information

- 1.1. Viva Couplings are designed to provide a mechanical connection between the rotating shafts of mechanical equipment, using a torsionally soft flexible element to accommodate inherent misalignment while transmitting the power and torque between the shafts.
- 1.2. These instructions are intended to help you to install and maintain your Viva coupling. Please read these instructions prior to installing the coupling, and prior to maintenance of the coupling and connected equipment. Keep these instructions near the coupling installation and available for review by maintenance personnel.
- 1.3. Rexnord Industries, LLC owns the copyright of this material. These Installation and Maintenance instructions may not be reproduced in whole or in part for competitive purposes.
- 1.4. Symbol descriptions:



Danger of injury to persons.



Damages on the machine possible.



Pointing to important items.

2. Safety and Advice Hints



DANGER!

- 2.1. Safety should be a primary concern in all aspects of coupling installation, operation, and maintenance.
- 2.2. All rotating power transmission products are potentially dangerous and can cause serious injury. They must be guarded in compliance with OSHA, ANSI and any other local standard for the applications they are used. It is the responsibility of the user to provide proper guarding.
- 2.3. Failure to secure capscrews properly could cause coupling component(s) to dislodge during operation and result in personal injury. See table 3 for proper tightening torques.
- 2.4. Do not use on turbine drives if the coupling cannot be protected from steam leakage or overspeed situations beyond the couplings published speed rating.
- 2.5. Before installing this coupling on systems involving sleeve bearings, herringbone gearsets or other axially sensitive devices, consult Rexnord.
- 2.6. Elastomeric couplings can hold a static electric charge that may discharge and ignite in an explosive environment. Both shafts of the connected equipment must have a path to ground.

3. Rexnord Viva Coupling Design and Part Numbers

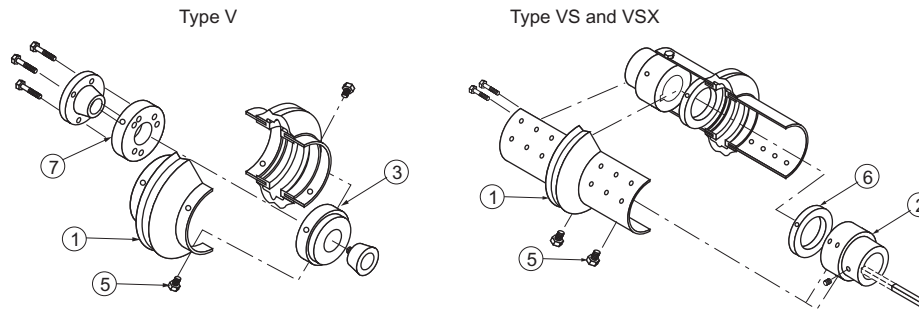

Table 1 – Viva Part Numbers

Coupling Size	Elastomer Element			Hubs				Element Cap Screws (5)	High Speed Rings (6)
	Type V (1)	Type VX (1)	Type VSX (1)	Rough Bore Steel (2)	Taper Bushed Hubs – Inch* (3)	British Standard Whitworth Threads (BSW)	QD Hubs* (7)		
110	7392646	7392702	7392702X	7392746	7392768	7392770	7392766	7393097	7393046
125	7392650	7392706	7392706X	7392774	7392797	7392799	7392795	7393097	7393049
130	7392654	7392710	7392710X	7392803	7392827	7392829	7392825	7393097	7393052
150†	7392656	7392712	7392712X	7392833	7392856	7392858	7392854	7393101	7393055
170†	7392658	7392714	7392714X	7392833	7392856	7392858	7392854	7393101	7393055
190	7392662	7392718	7392718X	7392862	7392884	7392886	7392882	7393101	7393058
215	7392666	7392722	7392722X	7392890	7392912	7392914	7392910	7393105	7393061
245	7392670	7392726	7392726X	7392918	7392933	7392935	7392931	7393105	7393064
290	7392674	7392730	7392730X	7392939	7392954	7392957	7392952	7393109	7393067
365	7392678	7392734	7392734X	7392960	7392966	7392969	7392964	7393120	7393070
425	7392682	7392738	7392738X	7392972	7392978	7392981	7392976	7393120	7393073
460	7392686	7392742	7392742X	7392984	7392990	7392993	7392988	7393120	7393076

Note: Hubs are interchangeable with standard or space flex elements.

* Bushings are not included.

† V150/V170 utilize same hubs.

4. Drive Alignment



Stop the motor and lock it out to prevent start-up during installation of coupling.

STEP 1

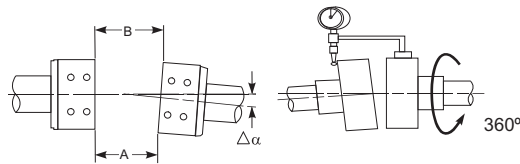

b (max) _____ mm

a (min) _____ mm

$$\Delta K = (b-a)$$

STEP 2

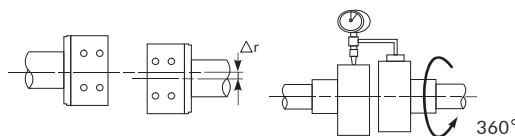

ΔKr _____ mm

ATTENTION! Improper alignment of the equipment or hubs may result in hub contact and sparking.

STEP 3

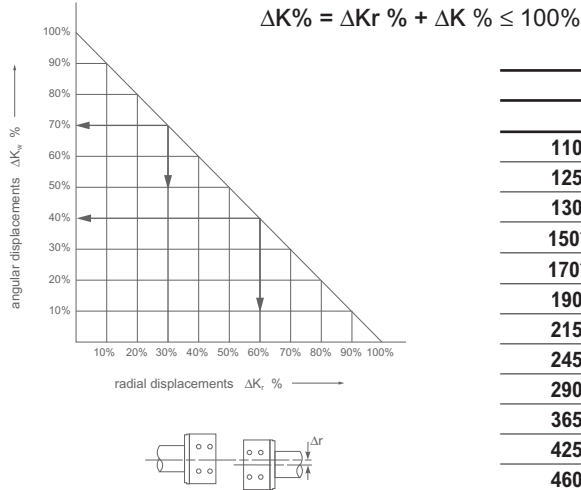
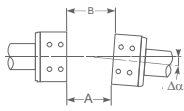
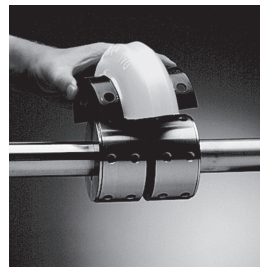

Table 2 - Drive Alignment				
	(b-a) mm	ΔKr mm	(b-a) inch	ΔKr inch
110	4,2	1,6	0.165	0.063
125	4,9	1,6	0.193	0.063
130	5,5	1,6	0.217	0.063
150*	6,1	1,6	0.240	0.063
170*	6,6	1,6	0.260	0.063
190	6,1	2,4	0.240	0.095
215	7,3	2,4	0.287	0.095
245	8,9	2,4	0.350	0.095
290	11,2	2,4	0.441	0.095
365	8,2	3,2	0.323	0.126
425	9,9	3,2	0.390	0.126
460	9,4	3,2	0.370	0.126

5. Rexnord Viva Coupling Installation

STEP 1

- 5.1. Clean dirt and burrs from shafts and hub bores.
- 5.2. Be sure the keys fit shafts properly.
- 5.3. Position both hubs on the shaft without tightening the setscrews.
- 5.4. Use a half element to set proper hub spacing.
- 5.5. When the hubs are properly spaced, tighten the setscrews.
- 5.6. When using tapered bushings, follow bushing manufacturers instructions.



Type V

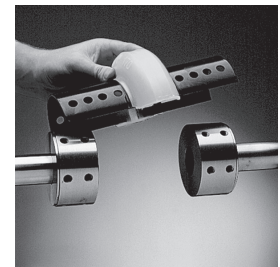

Type VS and VSX

STEP 2

- 5.7. Mount first half element to the hubs using cap screws provided.
- 5.8. Rotate the shaft 180 degrees and secure second half element.
- 5.9. If shaft cannot be rotated, mount half elements at 90 degrees.

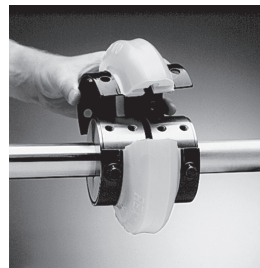

Type V

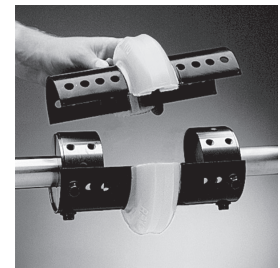

Type VS and VSX

STEP 3

- 5.10. Tighten all cap screws to the torques specified in Table 3.
- 5.11. Align equipment.
- 5.12. Install proper guarding prior to equipment start up.

ATTENTION! When installing the element, first seat all the cap screws with a light torque, then tighten all cap screws to proper torque using a torque wrench.



Type V

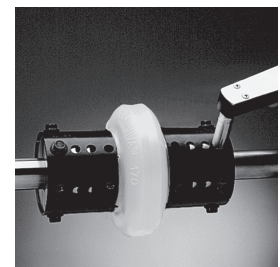

Type VS and VSX

6. Rexnord Viva Hub Mounting Options

- 6.1. Hubs can be installed:
- flush with the shaft end (D)
 - extended beyond the end of the shaft (E)
 - recessed behind the shaft end (F)

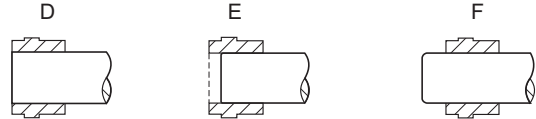

ATTENTION! Shaft engagement length should be >0,8 times shaft diameter, bushed hubs must engage 100%.

7. Cap Screw Torque

- 7.1. Do not lubricate cap screws threads.
 7.2. Cap screws must have a thread-locking adhesive applied.

Table 3 – Cap Screw Torque

Viva Size	Part No.	Bolt Size	Wrench Size mm	Torque			Viva Size	Part No.	Bolt Size	Wrench Size mm	Torque		
				Nm	ft lb	in lb					Nm	ft lb	in lb
110	7393097	M8	13	27	20	240	215	7393105	M10	13	53	39	468
125	7393097	M8	13	27	20	240	245	7393105	M10	13	53	39	468
130	7393097	M8	13	27	20	240	290	7393109	M12	15	92	68	816
150	7393101	M10	13	53	39	468	365	7393120	M14	19	158	117	1404
170	7393101	M10	13	53	39	468	425	7393120	M14	19	158	117	1404
190	7393101	M10	13	53	39	468	460	7393120	M14	19	158	117	1404

8. Rexnord Viva “Type V” Mounting Options

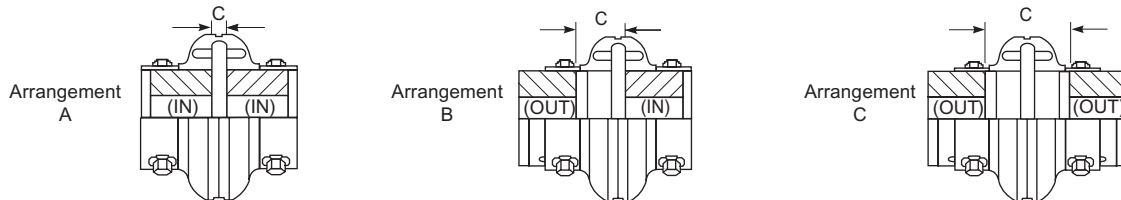

Table 4 – Type V Mounting Options

Hub Arrangement	Coupling Sizes											
	110	125	130	150	170	190	215	245	290	365	425	460
	Dimension C (mm)											
A	9	9	7	9	9	7	11	7	8	20	19	19
B	32	32	31	35	35	34	38	40	54	76	76	76
C	55	55	55	60	60	60	64	73	94	131	133	132

9. Rexnord Viva “Type VS and VSX” Mounting Options

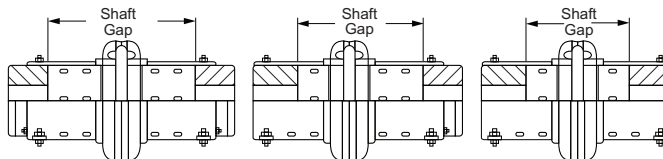
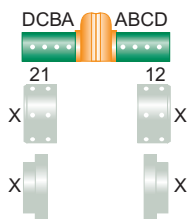

Table 5 – Mounting Options for Industry Standard Shaft Gaps

Viva Size	ISO (mm)					ANSI (inch)				
	100	140	180	250	300	3,5	5	7	9,5	11,75
110	C2-B1	C1-C1	C1-C1			B1-B1	C2-C1	C1-C1		
125	B1-B1	C1-C2*	C1-C1			B1-B2	C2-C2*	C1-C1		
130	C2-C2	C1-C1	C1-C1			B1-B1	C2*-C2*	C1-C1		
150	B1-B1	C1-C1	D1-D1	C1-C1		B1*-D1*	D1*-D1*	D1-D2*	C1-C1	
170	B1-B1	C1-C1	D1-D1	C1-C1		B1*-D1*	D1*-D1*	D1-D2*	C1-C1	
190	B1-B1	C1-C1	D1-D1	C1-C1		C1*-C1*	D1*-D1*	D1-D1	C1-C1	
215	B1-B1	C1-C1	D1-D1	C1-C1		C1*-C1*	D1*-D1*	D1-D1	C1-C1	
245	B1*-B2	D1-C1*	D2-D1	C1-C1		B1*-D1*	B2-C1	D1-C1	C2-C2	
290	B2*-B2*	B2*-B1	C1-B2*	C1-C1	C1-C1	B1*-B2*	C2*-B1*	B2-B1	C1-C2	C1-C1
365	...	C1*-C1*	B1-B1	C1-C1	C1-C1	...	B1-B1*	B1-B1	C1-C1	D1-D1
425	...	C2*-C2	B1-B1	C1-C1	C1-C1	...	B1-B2*	B1-B1	C1-C1	D1-D1
460	...	C2*-C2*	B1-B1	C1-C1	C1-C1	...	B2-B2*	B1-B1	C1-C1	D1-D1

* Hub mounted inboard.

■ VSX Couplings.

10. Preventative Maintenance



Do not make contact with the coupling when it is rotating and/or in operation

- 10.1. Periodic visual inspection is necessary to evaluate the condition of the flex element. Inspection can be done during the operation using a strobe light.
- 10.2. When inspecting the element look for:
 - Fatigue cracks at element splits
 - Discoloration
 - Surface cracking in body of element.

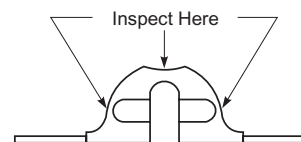

ATTENTION! Replace Element if necessary.

11. Element Replacement



Stop the motor and lock it out to prevent start-up during installation of coupling.

- 11.1. Always replace both half elements.
- 11.2. Install both half elements from the same box.
- 11.3. Follow installation instructions (see Section 5, Rexnord Viva Coupling Installation).
- 11.4. Tighten element cap screws to proper torque (see Table 3).