

PSN

The helical precision planetary gearbox for low-noise operation and high bearing loads

Our **PSN** is pure progress: Its helical gearing ensures low-noise synchronization. With this precision planetary gearbox, vibrations are reduced to a minimum. Precision even under very high loads makes the **PSN** one of the most high-performance gearboxes in the world.

Nominal output torque **28 - 950 Nm**



Radial force **3200 - 20000 N**

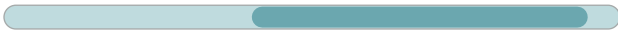

Axial force **4400 - 19000 N**



Torsional backlash **1 - 5 arcmin**



Protection class **IP65**



Frame sizes

- 70
- 90
- 115
- 142
- 190

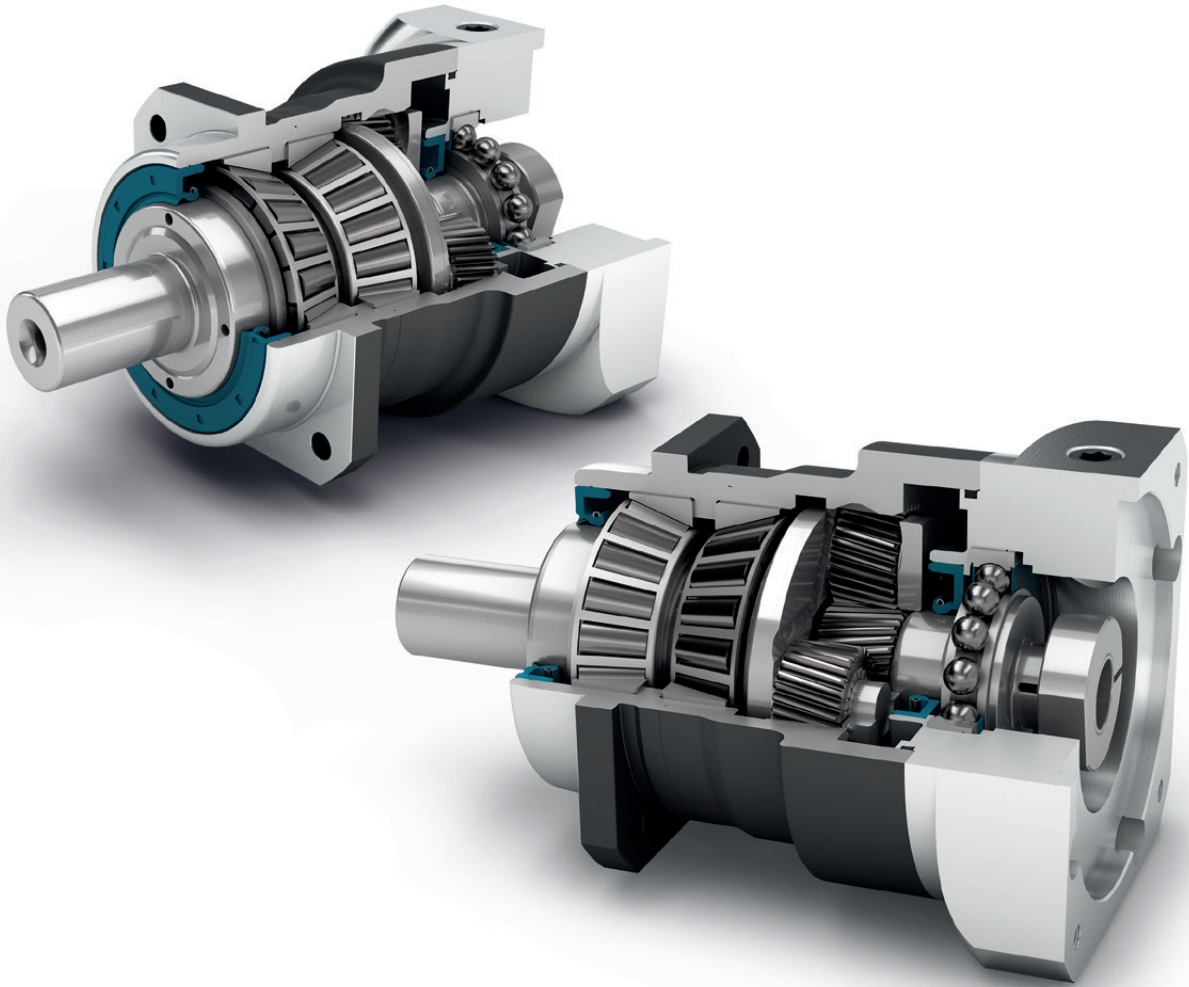

Precision Line



Equidirectional rotation



Square type output flange



Rotary shaft seal



Planet carrier in cage design



Option: Splined output shaft (DIN 5480)

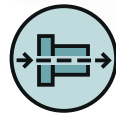

Coaxial gearbox



Helical gear



Preloaded tapered roller bearings



Extra long centering collar



Option: Reduced backlash



Option: Planetary gearbox with mounted pinion on page 132

Detailed explanations of the technical features starting on page 173.

Code	Gearbox characteristics			PSN070	PSN090	PSN115	PSN142	PSN190	p ⁽¹⁾
	Service life (L _{10h})	t _L	h	20,000					
	Service life at T _{2N} x 0.88			30,000					
	Efficiency at full load ⁽²⁾	η	%	98					1
				97					2
	Min. operating temperature	T _{min}	°C (°F)	-25 (-13)					
	Max. operating temperature	T _{max}		90 (194)					
	Protection class				IP65				
S	Standard lubrication				Oil (lifetime lubrication)				
F	Food grade lubrication				Oil (lifetime lubrication)				
L	Low temperature lubrication ⁽³⁾				Oil (lifetime lubrication)				
	Installation position				Any				
S	Standard backlash	j _t	arcmin	< 3					1
R	Reduced backlash			< 5					2
	Torsional stiffness ⁽²⁾	c _g	Nm /arcmin (lb _f .in/ arcmin)	3.6 - 4.8 (32 - 42)	9.2 - 13.0 (81 - 115)	22.0 - 34.5 (195 - 305)	62.0 - 88.0 (549 - 779)	181.0 - 246.0 (1602 - 2177)	1
					3.6 - 5.0 (32 - 44)	10.2 - 13.8 (90 - 122)	28.0 - 39.5 (248 - 350)	61.0 - 85.0 (540 - 752)	179.0 - 255.0 (1584 - 2257)
	Gearbox weight ⁽²⁾	m _G	kg (lb _m)	1.9 - 2.0 (4.3 - 4.4)	3.4 - 3.5 (7.6 - 7.7)	6.8 - 7.1 (14.9 - 15.7)	15.3 - 15.8 (33.8 - 34.7)	34.9 - 36.7 (76.9 - 81.0)	1
					2.6 - 2.7 (5.7 - 5.9)	4.0 - 4.1 (8.8 - 9.0)	8.0 - 8.2 (17.6 - 18.0)	17.1 - 17.6 (37.6 - 38.8)	39.8 - 41.7 (87.8 - 91.9)
S	Standard surface				Housing: Steel – heat-treated and post-oxidized (black)				
	Running noise ⁽⁴⁾	Q _g	dB(A)	57	58	63	66	68	
	Max. bending moment based on the gearbox input flange ⁽⁵⁾	M _b	Nm (lb _f .in)	18 (159)	38 (336)	80 (708)	180 (1593)	300 (2655)	1
					18 (159)	18 (159)	38 (336)	80 (708)	180 (1593)

Output shaft loads			PSN070	PSN090	PSN115	PSN142	PSN190	p ⁽¹⁾
Radial force for 20,000 h ⁽⁶⁾⁽⁷⁾	F _{r20.000h}	N (lb _f)	3200 (719)	5500 (1236)	6000 (1349)	13000 (2923)	20000 (4496)	
Axial force for 20,000 h ⁽⁶⁾⁽⁷⁾	F _{a20.000h}		4400 (989)	6400 (1439)	8000 (1798)	15000 (3372)	19000 (4271)	
Radial force for 30,000 h ⁽⁶⁾⁽⁷⁾	F _{r30.000h}		3200 (719)	4800 (1079)	5400 (1214)	11500 (2585)	17500 (3934)	
Axial force for 30,000 h ⁽⁶⁾⁽⁷⁾	F _{a30.000h}		3900 (877)	5700 (1281)	7000 (1574)	13500 (3035)	18500 (4159)	
Maximum radial force ⁽⁷⁾⁽⁸⁾	F _{rStat}		3200 (719)	5500 (1236)	6000 (1349)	13000 (2923)	20000 (4496)	
Maximum axial force ⁽⁷⁾⁽⁸⁾	F _{aStat}		4400 (989)	6400 (1439)	8000 (1798)	15000 (3372)	19000 (4271)	
Tilting moment for 20,000 h ⁽⁶⁾⁽⁸⁾	M _{K20.000h}	Nm (lb _f .in)	203 (1797)	419 (3708)	562 (4974)	1566 (13860)	2887 (25552)	
Tilting moment for 30,000 h ⁽⁶⁾⁽⁸⁾	M _{K30.000h}		203 (1797)	366 (3239)	506 (4478)	1385 (12258)	2526 (22357)	

Moment of inertia			PSN070	PSN090	PSN115	PSN142	PSN190	p ⁽¹⁾
Mass moment of inertia ⁽²⁾	J	kgcm ² (lb _f .in.s ² 10 ⁻⁴)	0.128 - 0.272 (1.133 - 2.407)	0.330 - 0.811 (2.921 - 7.178)	0.857 - 2.484 (7.585 - 21.985)	6.475 - 13.112 (57.309 - 116.051)	21.695 - 53.182 (192.017 - 470.700)	1
			0.123 - 0.177 (1.089 - 1.567)	0.124 - 0.204 (1.097 - 1.806)	0.321 - 0.600 (2.841 - 5.310)	0.840 - 1.962 (7.435 - 17.365)	6.360 - 10.654 (56.291 - 94.296)	2

(1) Number of stages
 (2) The ratio-dependent values can be retrieved in Tec Data Finder – www.neugart.com
 (3) T_{min} = -40°C. Optimal operating temperature max. 50°C
 (4) Sound pressure level from 1 m, measured on input running at n₁=3000 rpm no load; i=5
 (5) Max. motor weight* in kg = 0.2 x M_b / motor length in m
 * with symmetrically distributed motor weight
 * with horizontal and stationary mounting
 (6) These values are based on an output shaft speed of n₂=100 rpm
 (7) Based on center of output shaft
 (8) Other (sometimes higher) values following changes to T_{2N}, F_r, F_a, cycle, and service life of bearing. Application specific configuration with NCP – www.neugart.com

Output torques			PSN070	PSN090	PSN115	PSN142	PSN190	i ⁽¹⁾	p ⁽²⁾
Nominal output torque ⁽³⁾⁽⁴⁾	T _{2N}	Nm (lb _r .in)	29 (257)	54 (478)	135 (1195)	380 (3363)	845 (7479)	3	1
			39 (345)	80 (708)	180 (1593)	470 (4160)	950 (8408)	4	
			40 (354)	80 (708)	175 (1549)	405 (3585)	950 (8408)	5	
			37 (327)	78 (690)	175 (1549)	355 (3142)	900 (7966)	7	
			39 (345)	75 (664)	155 (1372)	350 (3098)	-	8	
			28 (248)	59 (522)	140 (1239)	305 (2699)	750 (6638)	10	
		2	29 (257)	54 (478)	135 (1195)	380 (3363)	845 (7479)	12	
			29 (257)	54 (478)	135 (1195)	380 (3363)	845 (7479)	15	
			39 (345)	80 (708)	180 (1593)	450 (3983)	950 (8408)	16	
			39 (345)	80 (708)	180 (1593)	450 (3983)	950 (8408)	20	
			40 (354)	80 (708)	175 (1549)	405 (3585)	950 (8408)	25	
			40 (354)	80 (708)	175 (1549)	405 (3585)	950 (8408)	35	
			39 (345)	80 (708)	180 (1593)	470 (4160)	950 (8408)	40	
			40 (354)	80 (708)	175 (1549)	405 (3585)	950 (8408)	50	
			37 (327)	78 (690)	175 (1549)	355 (3142)	900 (7966)	70	
			28 (248)	59 (522)	140 (1239)	305 (2699)	750 (6638)	100	
Max. output torque ⁽⁴⁾⁽⁵⁾	T _{2max}	Nm (lb _r .in)	46 (407)	86 (761)	216 (1912)	608 (5381)	1352 (11966)	3	1
			62 (549)	128 (1133)	288 (2549)	752 (6656)	1520 (13453)	4	
			64 (566)	128 (1133)	280 (2478)	648 (5735)	1520 (13453)	5	
			59 (522)	125 (1106)	280 (2478)	568 (5027)	1440 (12745)	7	
			62 (549)	120 (1062)	248 (2195)	560 (4956)	-	8	
			45 (398)	94 (832)	224 (1983)	488 (4319)	1200 (10621)	10	
		2	46 (407)	86 (761)	216 (1912)	608 (5381)	1352 (11966)	12	
			46 (407)	86 (761)	216 (1912)	608 (5381)	1352 (11966)	15	
			62 (549)	128 (1133)	288 (2549)	720 (6373)	1520 (13453)	16	
			62 (549)	128 (1133)	288 (2549)	720 (6373)	1520 (13453)	20	
			64 (566)	128 (1133)	280 (2478)	648 (5735)	1520 (13453)	25	
			64 (566)	128 (1133)	280 (2478)	648 (5735)	1520 (13453)	35	
			62 (549)	128 (1133)	288 (2549)	752 (6656)	1520 (13453)	40	
			64 (566)	128 (1133)	280 (2478)	648 (5735)	1520 (13453)	50	
			59 (522)	125 (1106)	280 (2478)	568 (5027)	1440 (12745)	70	
			45 (398)	94 (832)	224 (1983)	488 (4319)	1200 (10621)	100	

(1) Ratios (i=n₁/n₂)
 (2) Number of stages
 (3) Application specific configuration with NCP – www.neugart.com
 (4) Values for feather key (code "A"): for repeated load
 (5) 30,000 rotations of the output shaft permitted; see page 166

Output torques			PSN070	PSN090	PSN115	PSN142	PSN190	$i^{(1)}$	$p^{(2)}$		
Emergency stop torque ⁽³⁾	T_{2Stop}	Nm (lb _f .in)	90 (797)	210 (1859)	490 (4337)	1250 (11063)	2400 (21242)	3	1		
			120 (1062)	280 (2478)	650 (5753)	1650 (14604)	3200 (28322)	4			
			130 (1151)	280 (2478)	650 (5753)	1650 (14604)	3200 (28322)	5			
			80 (708)	175 (1549)	340 (3009)	1300 (11506)	3200 (28322)	7			
			90 (797)	200 (1770)	380 (3363)	1100 (9736)	-	8			
			90 (797)	200 (1770)	480 (4248)	600 (5310)	1700 (15046)	10			
			135 (1195)	220 (1947)	500 (4425)	1250 (11063)	2400 (21242)	12			
			135 (1195)	220 (1947)	500 (4425)	1250 (11063)	2400 (21242)	15			
					150 (1328)	300 (2655)	650 (5753)	1650 (14604)	3200 (28322)	16	2
					150 (1328)	300 (2655)	650 (5753)	1650 (14604)	3200 (28322)	20	
					150 (1328)	300 (2655)	650 (5753)	1650 (14604)	3200 (28322)	25	
					150 (1328)	300 (2655)	650 (5753)	1650 (14604)	3200 (28322)	35	
					150 (1328)	300 (2655)	650 (5753)	1650 (14604)	3200 (28322)	40	
					150 (1328)	300 (2655)	650 (5753)	1650 (14604)	3200 (28322)	50	
					80 (708)	175 (1549)	340 (3009)	1300 (11506)	3200 (28322)	70	
					80 (708)	200 (1770)	480 (4248)	600 (5310)	1700 (15046)	100	

Input speeds			PSN070	PSN090	PSN115	PSN142	PSN190	$i^{(1)}$	$p^{(2)}$		
Average thermal input speed at T_{2N} and S1 ⁽⁴⁾⁽⁵⁾	n_{IN}	rpm	3000 ⁽⁶⁾	2700 ⁽⁶⁾	2000 ⁽⁶⁾	1000 ⁽⁶⁾	750 ⁽⁶⁾	3	1		
			3700 ⁽⁶⁾	3050 ⁽⁶⁾	2250 ⁽⁶⁾	1250 ⁽⁶⁾	900 ⁽⁶⁾	4			
			4400 ⁽⁶⁾	3700 ⁽⁶⁾	2750 ⁽⁶⁾	1550 ⁽⁶⁾	1100 ⁽⁶⁾	5			
			4500	4000	3500 ⁽⁶⁾	2000 ⁽⁶⁾	1450 ⁽⁶⁾	7			
			4500	4000	3500	2200 ⁽⁶⁾	-	8			
			4500	4000	3500	2500 ⁽⁶⁾	1900 ⁽⁶⁾	10			
			4500	4500	4000 ⁽⁶⁾	2400 ⁽⁶⁾	1550 ⁽⁶⁾	12			
			4500	4500	4000	3000 ⁽⁶⁾	1900 ⁽⁶⁾	15			
					4500	4500	4000 ⁽⁶⁾	2600 ⁽⁶⁾	1650 ⁽⁶⁾	16	2
					4500	4500	4000	3250 ⁽⁶⁾	2050 ⁽⁶⁾	20	
					4500	4500	4000	3500 ⁽⁶⁾	2200 ⁽⁶⁾	25	
					4500	4500	4000	3500	2800 ⁽⁶⁾	35	
					4500	4500	4000	3500	3000 ⁽⁶⁾	40	
					4500	4500	4000	3500	3000	50	
					4500	4500	4000	3500	3000	70	
					4500	4500	4000	3500	3000	100	
Max. mechanical input speed ⁽⁴⁾	n_{1Limit}	rpm	14,000	10,000	8500	6500	6000		1		
			14,000	14,000	10,000	8500	6500		2		

(1) Ratios ($i=n_1/n_2$)
 (2) Number of stages
 (3) Permitted 1000 times
 (4) Application-specific speed configurations with NCP – www.neugart.com
 (5) See page 166 for the definition
 (6) Average thermal input speed at 50% T_{2N} and S1

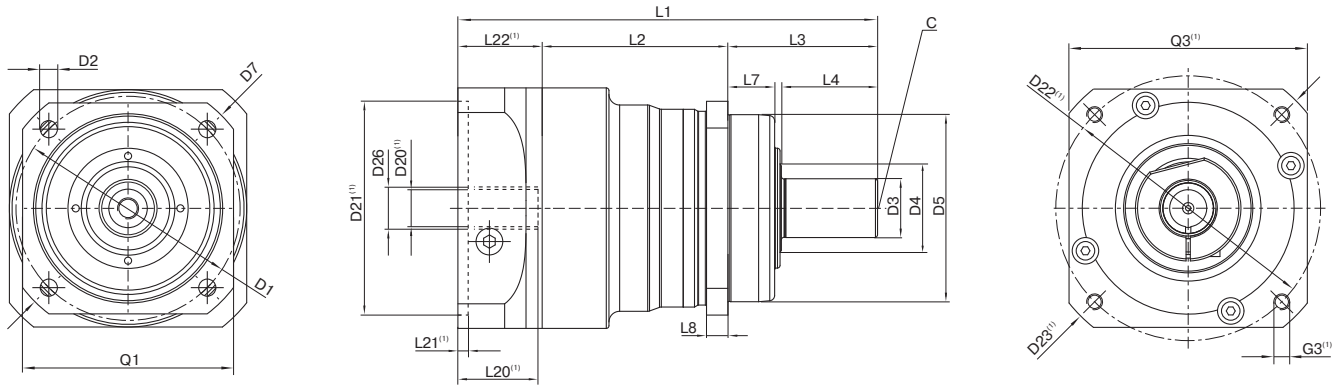

Drawing corresponds to a PSN090 / 1-stage / smooth output shaft / 14 mm clamping system / motor adaptation – 2-part – round universal flange / B5 flange type motor

⁽¹⁾ The dimensions vary with the motor/gearbox flange. The input flange dimensions can be retrieved for each specific motor in Tec Data Finder at www.neugart.com

Geometry ⁽²⁾			PSN070	PSN090	PSN115	PSN142	PSN190	p ⁽³⁾	Code
Pitch circle diameter output	D1		68 - 75 (2.677 - 2.953)	85 (3.346)	120 (4.724)	165 (6.496)	215 (8.465)		
Mounting bore output	D2	4x	5.5 (0.217)	6.5 (0.256)	9.0 (0.354)	11.0 (0.433)	13.5 (0.531)		
Shaft diameter output	D3	k6	16 (0.630)	22 (0.866)	32 (1.260)	40 (1.575)	55 (2.165)		
Shaft collar output	D4		21.5 (0.846)	31.5 (1.240)	41.5 (1.634)	57.5 (2.264)	76.5 (3.012)		
Centering diameter output	D5	g7	60 (2.362)	70 (2.756)	90 (3.543)	130 (5.118)	160 (6.299)		
Diagonal dimension output	D7		92 (3.622)	100 (3.937)	140 (5.512)	185 (7.283)	240 (9.449)		
Flange cross section output	Q1	■	70 (2.756)	80 (3.150)	110 (4.331)	142 (5.591)	190 (7.480)		
Min. total length	L1		134 (5.276)	157 (6.181)	202.5 (7.972)	261.5 (10.295)	310.5 (12.224)	1	
			162.5 (6.398)	179 (7.047)	224.5 (8.839)	292.5 (11.516)	355.5 (13.996)	2	
Housing length	L2		60.5 (2.382)	69.5 (2.736)	71 (2.795)	101.5 (3.996)	130.5 (5.138)	1	
			89 (3.504)	98 (3.858)	104.5 (4.114)	139 (5.472)	194 (7.638)	2	
Centering depth output	L7		19 (0.748)	17.5 (0.689)	28 (1.102)	28 (1.102)	28 (1.102)		
Flange thickness output	L8		7 (0.276)	8 (0.315)	10 (0.394)	12 (0.472)	15 (0.591)		
Center hole (DIN 332. type DR)	C		M5x12.5	M8x19	M12x28	M16x36	M20x42		
Motor shaft diameter j6/k6	D20		More information on page 163/164						
Clamping system diameter input	D26		More information on page 163/164						
Output shaft with feather key (DIN 6885-1)			A 5x5x25	A 6x6x28	A 10x8x50	A 12x8x65	A 16x10x70		
Feather key width (DIN 6885-1)	B1		5 (0.197)	6 (0.236)	10 (0.394)	12 (0.472)	16 (0.630)		
Shaft height including feather key (DIN 6885-1)	H1		18 (0.709)	24.5 (0.965)	35 (1.378)	43 (1.693)	59 (2.323)		
Shaft length output	L3		48 (1.890)	56 (2.205)	88 (3.465)	110 (4.331)	112 (4.409)		A
Shaft length from shoulder	L4		28 (1.102)	36 (1.417)	58 (2.283)	80 (3.150)	82 (3.228)		
Feather key length	L5		25 (0.984)	28 (1.102)	50 (1.969)	65 (2.559)	70 (2.756)		
Distance from shaft end	L6		2 (0.079)	4 (0.157)	4 (0.157)	8 (0.315)	6 (0.236)		
Smooth output shaft									
Shaft length output	L3		48 (1.890)	56 (2.205)	88 (3.465)	110 (4.331)	112 (4.409)		B
Shaft length from shoulder	L4		28 (1.102)	36 (1.417)	58 (2.283)	80 (3.150)	82 (3.228)		
Splined output shaft (DIN 5480)			W16x0.8 x18x6m	W22x1.25 x16x6m	W32x1.25 x24x6m	W40x2.0 x18x6m	W55x2.0 x26x6m		
Width of gearing	L _v		15 (0.591)	15 (0.591)	15 (0.591)	20 (0.787)	22 (0.866)		C
Shaft length output	L3		46 (1.811)	46 (1.811)	56 (2.205)	70 (2.756)	71.5 (2.815)		
Shaft length from shoulder	L4		26 (1.024)	26 (1.024)	26 (1.024)	40 (1.575)	41.5 (1.634)		

⁽²⁾ Dimensions in mm

⁽³⁾ Number of stages